



MERLO

INSTRUCTION MANUAL

KEEP THIS MANUAL WITH THE MACHINE AT ALL TIMES

P25.6

TRANSLATION OF THE ORIGINAL INSTRUCTIONS

PAN25-07 (AU)

M2-P256-AU-01

M3-ZM2-03 (EN)

CHASSIS

C6184487

(AU)

87



PUBLICATION DATE

04/2017



INTRODUCTION	1
MACHINE TECHNICAL SPECIFICATIONS	2
STICKERS WITH CONTROL DESCRIPTIONS - LEAFLETS IN THE CABIN.....	3
CONTROLS AND INSTRUMENTS.....	4
OPERATING INSTRUCTIONS.....	5
ORDINARY MAINTENANCE	6
SECURITY PERIODICAL INSPECTIONS	7
ATTACHMENTS AND OPTIONAL EXTRA	8
HYDRAULIC CIRCUITS' DIAGRAMS	9
ELECTRICAL SYSTEM	10

**INDEX**

GENERAL NOTES	2
SCOPE OF USE OF THE MACHINE	2
OPERATOR MANUAL.....	2
WORK ENVIRONMENT	3
FIRST COMMISSIONING OR RECOMMISSIONING AFTER A LONG SHUTDOWN.....	3
MACHINE GARAGING	3
TYRES.....	3
ORIGINAL MERLO SPARES	4
MACHINE SCRAPPING	4
GUARANTEE	4
ORDINARY MAINTENANCE OPERATIONS.....	4
DRIVING THE MACHINE ON PUBLIC ROADS	4
SAFETY AND ACCIDENT PREVENTION MEASURES.....	5
FIRE PREVENTION MEASURES	6
AS1418.19 COMPLIANCE	6
END OF CHAPTER	7



GENERAL NOTES

This manual refers to AS1418.19

This machine has been designed and manufactured according to MERLO specifications. In order to avoid accidents and ensure the best performances over time, the machine must not be modified or altered in any way and all safety rules, as well as the general operation instructions described in chapter "SAFETY PREVENTION MEASURES" of this instruction manual shall be respected.

Any change made to either the machine or its attachments by subjects other than Merlo S.p.A. shall forfeit the manufacturer's liability and suspend warranty. Any civil or criminal consequences shall fall on the subject who has made the change.

All information, images and specifications contained in this manual are based on the updated product at the time of publication. MERLO S.p.a. reserves the right to make all the necessary changes it will deem necessary with no prior notice.

Entrust the machine only to qualified and skilled staff whose characteristics are compliant with existing legal requirements. The non observation of what indicated by this document may cause personal or material damage.

Both machine and loads handlings must be carried out in a people-free range.

SCOPE OF USE OF THE MACHINE

This machine is designed and manufactured for agricultural and industrial applications. Any use in other sectors is to be considered not compliant with its scope of use.

Compliance and strict adherence to Manufacturer's specifications for use, storage and maintenance are also fundamental for the scope of use of this machine.

This machine shall be used by qualified, skilled and authorized personnel only. Operators shall be familiar both with the various components of this machine and with the safety procedures to be followed if the need arises.

Any arbitrary changes made to this machine without prior written authorization from the Manufacturer exempt Merlo S.p.A. from any civil and/or criminal liability.

OPERATOR MANUAL

Before using your MERLO machine, it is necessary to carefully read the OPERATION AND MAINTENANCE MANUAL to fully understand all the operation, maintenance and safety information it contains.

The operator's manual is an integral part of the machine, it shall be written in a language spoken or at least understood by the operator and be held in the document holding pocket behind the driver's seat, so that it can be consulted at any time. Should the manual be damaged or made illegible in any of its parts, please order a new copy to Merlo Technical Support, by providing the identification code written in the bottom left-hand corner of the front page.

The stickers and leaflets found on the machine must always be present and accessible to the driver. Should these be unreadable, damaged or missing, it is necessary to order them again from the Merlo Technical Support Service indicating the overprinted code or referring to chapter "ADHESIVE CONTROL LABELS" of the machine operator manual.

If the machine is fitted with special applications supplied under specific customer request, which are not included in the official list of accessories, the related instructions can be found in the last page of this manual.

Any device and/or label found on the machine and not described by the present manual is related to applications installed under specific customer request; in this case the specific operating instructions shall be supplied separately.

The complete or partial reproduction of the Merlo operator manual is forbidden.

SYMBOLS USED IN THE MANUAL

The operator manual contains some graphic symbols which help the user understand the importance of instructions and highlight any specific precautions to be taken or general notes:

WARNING!

This symbol indicates important messages aimed at ensuring driver and vehicle safety. In such cases it is necessary to carefully read the text following the symbol and strictly follow the instructions given.



NOTE!

This symbol precedes a closer description of an instruction and aims at highlighting a part of the text.



HEXAGONAL KEY

This symbol is used to identify the dimension of the key to be used for some operations described in the manual.

The type of key is indicated only if different from the standard one.

Only use ISO sockets or wrenches. The number inside the symbol is in millimeters.



OPERATOR MANUAL SYMBOL

This symbol is shown on some machine plates and warns the operator that the explanations contained in the Operator manual shall be carefully read before using the control.





WORK ENVIRONMENT

The machine manufactured by Merlo S.p.a., are designed to be used within the following environmental temperature ranges:

- minimum temperature: - 20°C (-4 °F)
- maximum temperature: + 40°C (100°F)

Special applications may be provided upon request for particularly cold or hot environments.

A single fire extinguisher should be fitted on the machine when the workplace does not have external fire extinguishing equipment and the risk of fires exists.

Always take the atmospheric and climatic conditions of the workplace into account.

The machine is supplied with a leaflet stating the maximum permissible wind under normal operating conditions. Before using the machine read the table showing the Beaufort scale to estimate wind strengths, so that you can check whether there are the right conditions to ensure safety when working at a certain height.

Please note that the maximum permissible value is 12.5 m/s (28 mph) (level 6 on the "Beaufort scale").

Merlo machines are fitted for outdoor use.

When using them in closed, underground environments or in places where a risk of explosion exists, special equipment can be fitted on the machine. These shall be defined when ordering the machine and its attachments.

FIRST COMMISSIONING OR RECOMMISSIONING AFTER A LONG SHUTDOWN

Before operating the machine for the first time, or after a long shutdown, the following operations shall be carried out:

- check that the machine is not damaged
- check that the mechanic parts of the machine are in prime condition, and not rusted
- check both the engine coolant level and the coolant level for the service hydraulic system
- check the tire wear level
- check that the lights and the electrical equipment work correctly
- check for any oil leaks from the unions or the pipes of the hydraulic system
- check both the battery electrolyte level and the battery charge
- check that all protection devices are in their correct positions
- thoroughly grease all the mobile parts of the machine

MACHINE GARAGING

If the machine needs to be shut down for a prolonged period of time, it shall be garaged in a place where it is not exposed to atmospheric agents, and it shall be protected to avoid any damages.

Before being garaged, the machine shall be cleaned down and all its mechanical parts shall be properly lubricated to prevent rusting.

Check that the temperature in the garage ranges between 0°C (32°F) and 50°C (120°F). For temperatures below 0°C (32°F), but not below -29°C (-20°F), check the density of the antifreeze in the engine cooling system. The main operations to be carried out before garaging the machine for a prolonged period of time are listed below. Please follow these instructions:

- clean down the whole machine.
- perform a general visual inspection of the machine, so that you can identify any structural damage and/or deep abrasions on painted surfaces.
- perform a general visual inspection of the machine, so that you can check whether all safety plates and stickers are in place and in prime condition. Replace the damaged or illegible plates and/or stickers with new ones, to be ordered from the Merlo Technical Support Service.
- lubricate and grease all mechanical parts, as well as all the pins exposed to the air.
- garage the machine in a sheltered place, and park it on a flat, compact surface.
- apply the parking brake.
- take the engine start key out of the dashboard, lock the cab door and store the key in a safe place.

TYRES

Only use tyres approved by Merlo S.p.a.

If tyres are deteriorated or show excessive wear, they must be replaced with new tyres with the same characteristics.

Fit tyres suited to the surface of work - several types of tyres exist (for agricultural or industrial use, sandy terrains etc.). If needed, or in case of abnormal wear, contact your dealer.

Do not fit polyurethane-filled or fluid-filled tyres if not explicitly authorised by Merlo S.p.a.



WARNING! The list of authorised tyres which may be fitted to your machine is provided in the paragraph FEATURES AND PERFORMANCES in the TECHNICAL DATA section.

If it is necessary to replace one type of tyre with another model (included in the list of authorised tyres), first contact Merlo's Technical Support service since replacing the tyres may also require replacement of the electronic control unit managing safety and load tables.



ORIGINAL MERLO SPARES

Maintenance operations on Merlo machines shall be carried out only with original and approved spare parts. In this way, the customer is legally covered and has the following advantages:

- guaranteed quality of spare parts
- guaranteed training of the technical staff
- support in preventive maintenance operations
- support in diagnosis operations

If NON original Merlo spare parts are used, the customer runs the following risks:

- from a technical point of view, this may damage or cause general operation problems to the machine
- from a legal point of view, the customer may be deemed directly liable in case of accidents
- from an economic point of view, any claims for repairs carried out in the warranty period (materials and labour) may be rejected.

In this case Merlo S.p.A holds itself free from any liability, and the warranty terms on the machine shall no longer be applicable. Finally, only Merlo S.p.A has all the technical and engineering know-how which ensures maximum expertise in the maintenance of its machines.

MACHINE SCRAPPING

When the machine is scrapped, it shall be disposed of in proper dumps, in compliance with the law as it stands. Before scrapping the machine, sort out plastic or rubber parts, as well as electric or electronic parts, from other components. Recover used oil and dispose of it in proper collection centres.

Parts which are solely made of plastic, aluminium or steel can be recycled if they are collected in proper collection centres.



IMPORTANT! Used oil shall be properly recovered, and not be released into the environment. Current legislation classifies it as a hazardous substance, therefore it shall be disposed of in proper collection centres.

GUARANTEE

To benefit from the Manufacturer's guarantee, the operator shall take all the precautions described in the Operator's Manual, with particular reference to the following:

- obey the prescriptions and restrictions provided by the Manufacturer for machine operation
- never make any changes to the machine without prior written authorization from the Manufacturer
- always carry out all the maintenance operations prescribed by the Manufacturer
- always use Merlo original spare parts
- make sure that the staff operating the vehicle have the necessary skills and are properly trained.

The Manufacturer's guarantee shall not apply if the conditions above are not met, or are only partially met.

If spare parts which are not approved by the Manufacturer are used, any guarantee shall be made void and the Manufacturer shall be exempt from any liability for malfunctions or accidents.

If safety devices are either removed or altered, the Manufacturer shall be exempt from any liability for damages to property and/or people.

ORDINARY MAINTENANCE OPERATIONS

In order to ensure that the machine is used in maximum safety, reliability and efficiency conditions, it is key to regularly carry out all ordinary maintenance operations following closely the instructions provided by the present operator manual.

Do not use the machine unless all maintenance operations and any necessary repair work have been executed.

Should the operator notice that the machine does not operate as it should or it does not meet all safety requirements, the anomaly shall be immediately communicated to the person in charge.

Before carrying out any work on the machine, the engine must be stopped, the travel direction selector must be brought to its central position and the gear selector must be in neutral gear.

Maintenance operations must be carried out by qualified and skilled staff. For any work on parts which fall outside the scope of ordinary maintenance operations - as defined by the present operator manual - contact the Merlo Technical Support Service.

It is strictly forbidden and highly dangerous to modify any machine component thus changing its original structure. It is further forbidden to change the hydraulic and electric setup or modify the safety systems. Otherwise, Merlo S.p.A shall be relieved from any civil or criminal liability.

DRIVING THE MACHINE ON PUBLIC ROADS

For all information on how to drive the machine on public roads, always refer to the applicable laws of the country where the machine is used.



SAFETY AND ACCIDENT PREVENTION MEASURES



IMPORTANT!

To prevent any conditions of risk, avoid accidents and injuries, minimize failures and improve the functionality and the durability of your machine, always operate your machine correctly, obey the rules described in the following sections of this paragraph, and take all the necessary precautions while working.

Merlo S.p.A. denies liability for any damage, accident or injury if the code of conduct described in the following sections of this paragraph is not applied:

• CONDITIONS FOR A SAFE USE OF YOUR MACHINE

- the machine is not intended for use in sectors other than the one it was designed for; any use other than the one specified by the manufacturer shall be considered improper.
- the machine shall be used by only one operator, sitting in the driver's cab.
- the machine shall only be used by authorized, skilled personnel. The operator shall read and understand all the instructions provided in this operator's manual, be sufficiently trained on the correct use of the machine, and hold a driving licence. Should the operator have any doubts on either the use of the machine or the interpretation of the manual, he/she shall contact the Manufacturer.
- to drive the machine from one spot to another, the operator shall sit correctly in the driver's seat; if this is not the case, the system will automatically lock the hydrostatic transmission.
- never operate the machine if you feel tired or sick, or if you are under the effect of alcohol, prescription drugs or illicit drugs.
- if you need to work either under poor visibility conditions or at night, always switch on the working lights available on your machine. As an alternative, you can install a proper external lighting system in the area you are working in.
- any arbitrary changes made to your machine shall exempt Merlo S.p.A. from any liability for any damages or injuries to the operator, third parties or property.
- inspect your machine very carefully before setting it at work.
- if you stop your machine on sloping ground, place wheel chocks (if present) under its wheels.
- avoid operating you machine on a muddy, sandy or soft ground.
- never use the controls or the pipes on the machine as holds; these components are mobile and cannot offer a stable grip.
- check tire inflation pressure at regular intervals, and make sure that it corresponds to the pressure value shown on the rim, which has been determined based on the kind of soil the machine is supposed to be operated on.
- never use your machine to transport people or animals.
- never use your machine to lift people or animals.
- always refer to the load diagram of your machine, which defines the maximum load capacity depending on the extension of the telescopic boom.
- never leave your machine unattended while the engine is still running or when loads are hanging from the telescopic boom.
- before getting off the machine and before carrying out any maintenance operations, apply the parking brake, switch off the engine and take the engine start key out of the dashboard.
- always fasten your seat belt while driving your machine from one spot to another on a site.

• PERSONAL PROTECTION SYSTEMS

- the personnel shall use both safety devices and personal protection devices during machine operation, servicing and maintenance. Machine operators shall avoid wearing jewellery or loose clothes that may get caught in machine parts or gears.
- if you usually work in particularly dusty or dry environments, you are advised to inspect the filters of the cab ventilation system periodically and to wear proper protection devices for you respiratory tract, such as dust masks or masks equipped with filters.
- some individual protection devices are shown here by way of example only. Such devices should be used by telehandler operators while working on and servicing their machines, as described in this chapter and in chapter "ROUTINE MAINTENANCE":

- Head protection helmet (fig. 1)
- Safety shoes (fig. 2)
- Safety gloves (fig. 3)
- Safety overalls (fig. 4)
- Safety goggles (fig. 5)
- Safety face mask (fig. 6)
- Respiratory mask (fig. 7)
- Earmuffs (fig. 8)

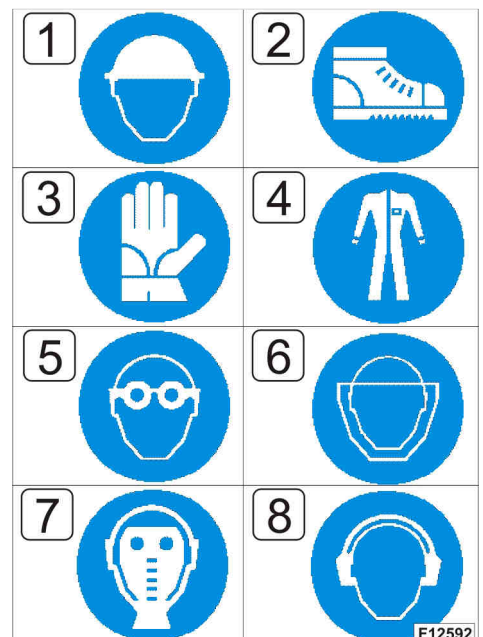

- such devices shall be made available by either the employer or the foreman, based on their risk assessment.



• MACHINE OPERATING AREA

- Before operating your machine, always check the workplace with extreme care, so as to prevent dangerous situations. Check the lie of the land and the soil condition, so as to equip your machine with the necessary equipment for safe operation.
- The operator shall make sure that no people or animals stand in or pass through the machine working area while the machine is in operation.
- Avoid any accidental contact between the telescopic boom and high-voltage overhead lines; keep a minimum distance of at least 5m (16 ft).

• SAFETY PLATES AND STICKERS

- safety plates and stickers applied on your machine provide important information; obeying the rules written on them is essential to your safety.
- make sure that the safety stickers and plates on your machine are in prime condition. Periodically clean all stickers and plates with a cloth dampened with a mild soap and water solution. Should stickers and plates be damaged or illegible, replace them with new original ones, to be ordered from Merlo Technical Support Service, and to be placed in the position shown in the Operator's Manual.

• SAFETY DEVICES

- before operating your machine, make sure that all safety devices are in good condition and placed in their correct positions; should guards and safety devices be faulty or damaged, stop working and file a replacement/repair claim.
- it is prohibited to either remove or tamper with safety devices.

• CLEANING YOUR MACHINE

- during machine operation the operator shall have enough visibility of the working areas which are considered dangerous; therefore, rear-view mirrors shall always be kept clean and in good condition.
- remove any foreign matter (rubble, tools, various objects) from your machine, since they may damage it or hurt the operator.
- periodically inspect the wear level of hydraulic pipes; if they are worn out, replace them.

FIRE PREVENTION MEASURES

Follow the instructions below:

- make sure that a fire extinguisher having a proper capacity is always available on board, and refill it periodically.
- inform machine operators about the measures to be taken in case of fire.
- note that all fuels and most lubricants and hydraulic fluids are flammable.
- never smoke or set anything aflame while refilling fluids, and never pour fuel.
- always switch off the engine before refuelling.
- never refuel in poorly ventilated rooms.
- before starting the engine make sure that there are no leaks or residual traces of fuel, lubricant, or other fluids which may cause small fires.
- short-circuits may cause fires. Periodically check the condition of the battery terminals, of cables and of the electrical equipment.
- never store flammable substances in places which are not suitable for that purpose; never prick or burn pressurized receptacles or spray cans; never let materials soaked in flammable substances accumulate.
- be careful where you store cloths or materials soaked in flammable substances.
- to minimize spontaneous ignition risks, periodically clean the machine with proper devices (either a high-pressure water jet cleaner or compressed air).
- use appropriate fire extinguishers: carbon dioxide extinguishers, foam extinguishers, chemical fire extinguishers.
- avoid using water jets; only use this method to cool down surfaces exposed to fire.
- never use petrol, solvents or other flammable or toxic fluids to clean mechanical parts; use commercial, non-flammable, atoxic solvents instead.
- never make welds near tanks, pipes, cans, cables, or flammable materials in general.
- if a weld needs to be made, protect flammable parts with proper shields.
- before making a weld always disconnect both battery terminals.

AS1418.19 COMPLIANCE

Your machine complies with the safety requirements of the Australian Standards (AS1418.19) for the protection and safety of people from potential hazards deriving from machine operation.

To ensure the operator's safety, the cabin is built in compliance with the following standards:

- ISO 3449 FALLING-OBJECT PROTECTIVE STRUCTURES (FOPS)
- ISO 3471 ROLL-OVER PROTECTIVE STRUCTURES (ROPS)

As it complies with the above mentioned requirements of the Safety directive, your machine is labeled with the AS1418.19 marking.



• MACHINE-PRODUCED VIBRATIONS

Your machine has been designed and built in compliance with international ergonomic standards.

The vibrations sent by the machine to the upper limbs of the operator's body are irrelevant, as the machine operation does not require a lengthy contact of upper limbs with vibrating parts. In any case, the value of such vibrations does not exceed 2.5 m/sec². Vibrations sent from the machine to the operator's body are less than 0.5 m/sec² (RMS).

• ELECTROMAGNETIC INTERFERENCE

This machine complies with Directive 2004/108/CE on electromagnetic interference which may arise between some electronic device on the vehicle and further external devices.

Make sure that all extra electric devices fitted on the machine comply with such standard and that they do not produce any interference with the vehicle on-board devices.

Also, make sure they are all labelled with the specific "CE" marking.

• NOISE

AIRBORNE NOISE

This machine is compliant with Directive 2000/14/EC on "noise emission in the environment of equipment for use outdoors".

The sound power level of your machine is determined based on measurements carried out on an identical machine in accordance with measurement methods of airborne noise generated by "combustion-engine driven counterbalanced lift trucks", whose validity applies at the time of publication of this manual.

The following table shows the sound power level (L_{wa}) measured:

TYPE OF MEASUREMENT	SOUND PRESSURE LEVEL
Guaranteed sound power level (L _{wa})	104 dB(A)

During equipment operation, higher noise levels may be measured due to particular working conditions, the surrounding environment and additional noise sources.



NOTE!

The guaranteed sound power level (L_{wa}) is also shown on a sticker applied on the inside of the cab window.

NOISE INSIDE THE CAB

Noise at the operator's ear is measured in compliance with EN 12053 standards for the "Determination of emission sound pressure level at operator's position".

The emission sound pressure level of your machine is determined based on measurements carried out on an identical machine in accordance with the measurement methods described in the aforementioned standards, whose validity applies at the time of publication of this manual.

The following table shows the sound pressure level measured inside the cab (L_{pAZ})

TYPE OF MEASUREMENT	SOUND PRESSURE LEVEL
Sound power level (L _{pAZ})	77 dB

Sound pressure uncertainty K_{pA} is equal to 2 dB.

The operating cycle during measurement is as follows:

- LIFTING (a=0.18)
- IDLING (b=0.58)
- PULLING (c=0.24)

Reference items a, b, and c are coefficients proportional to time of use.

During equipment operation, higher noise levels may be measured due to particular working conditions, the surrounding environment and additional noise sources.

END OF CHAPTER

**INDEX**

EXTERNAL VIEW OF THE MACHINE KEY WORDS	2
CAB INTERIOR KEY WORD.....	3
(P) CONTROL PANEL KEY WORDS.....	4
(P1) CONTROL PANEL KEY WORDS.....	5
DASHBOARD KEY WORDS (C)	5
DYNAMIC LOAD CONTROL DISPLAY KEY WORDS (D)	6
DIMENSIONS - P25.6.....	6
LOAD CHART.....	7
PERFORMANCE AND FEATURES	10
SERIAL NUMBER OF THE MACHINE	11
IDENTIFICATION AND TYPE APPROVAL PLATES.....	11
TIGHTENING TORQUES FOR ISO METRIC THREADS.....	12
END OF CHAPTER	12



EXTERNAL VIEW OF THE MACHINE KEY WORDS

Please, pay attention to the identification of the machine sides, because they will be requested in the handbook.

	REF.	DESCRIPTION
	A	Front side
	B	Rear side
	C	Left - hand side
D	Right - hand side	

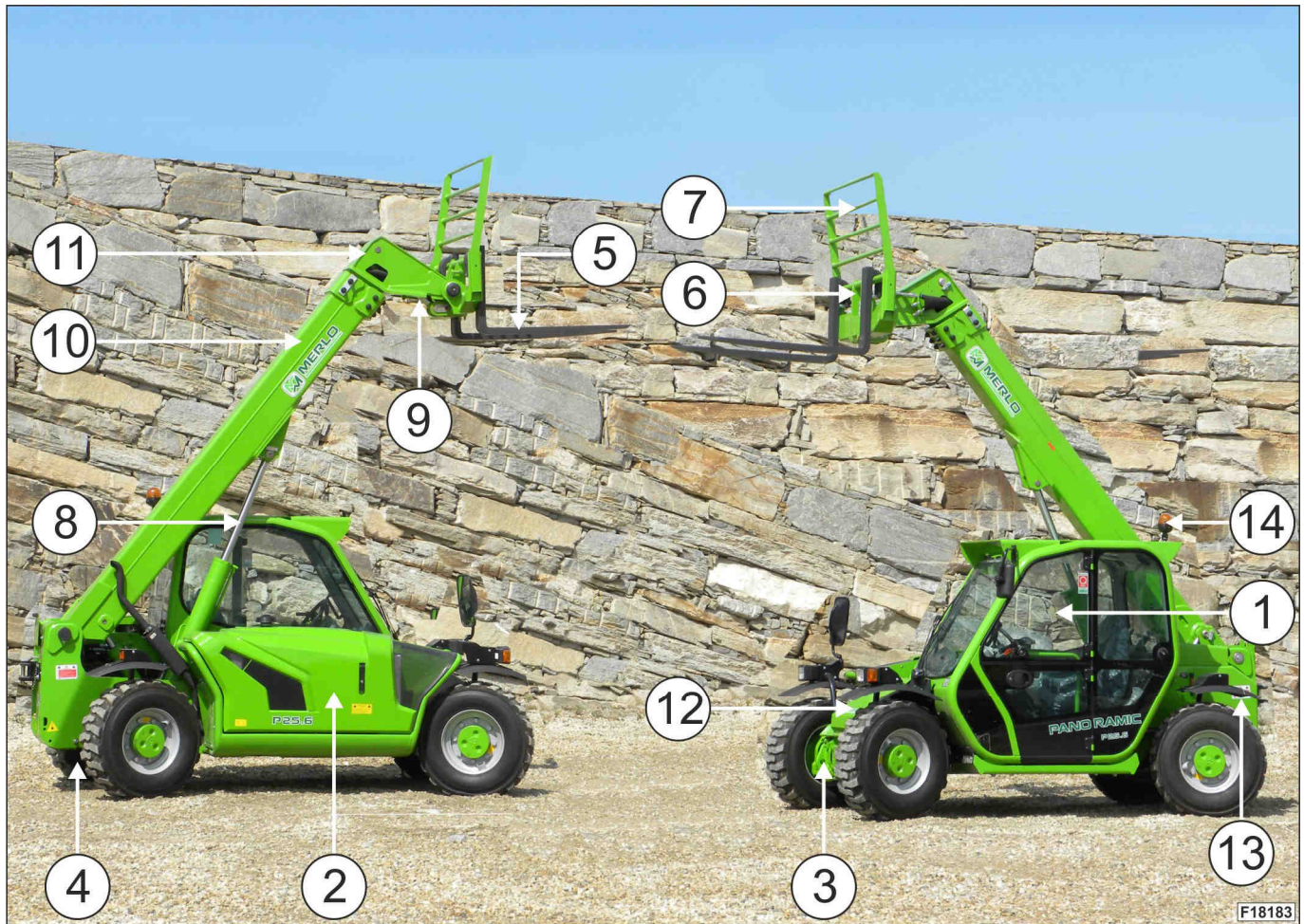

REF.	DESCRIPTION	REF.	DESCRIPTION
1	Operator cab	8	Lift cylinder of telescopic boom
2	Engine and Battery compartment	9	Forks tilting cylinder
3	Front axle - brake calipers - hub reduction gear	10	1st section boom
4	Rear axle - brake calipers - park brake caliper - hub reduction gear	11	2nd section boom
5	Forks	12	Fuel tank
6	Carriage	13	Hydraulic oil tank
7	Load back rest	14	Blinking light on the roof



CAB INTERIOR KEY WORD



REF.	DESCRIPTION	REF.	DESCRIPTION
1	Telescopic boom control joystick and driving direction buttons	26	Lever for air suction selection either inside/outside the cab
7	Rear windscreen-wiper switch	27	Driving speed adjustment pedal
12	Hydrostatic transmission or hydraulic system oil pressure gauge	28	Emergency pump for the release of the parking brake
13	Spirit level	29	Steering selection lever
14	Accelerator pedal	34	Front windscreen wiper and screen-washer switch
15	Brake pedal	35	Heating cock
17	Steering wheel position locking lever	86	Hand accelerator
18	Air vent	203	Activation of temporary bypass switch
20	Driving direction buttons	C	Dashboard
21	Safety instruction and load diagram container	D	Display of the dynamic attachment control
22	Steering wheel	P - P1	Control panels
24	Parking lights switch/ low beam lights / Direction indicators / head lights / Horn		



(P) CONTROL PANEL KEY WORDS

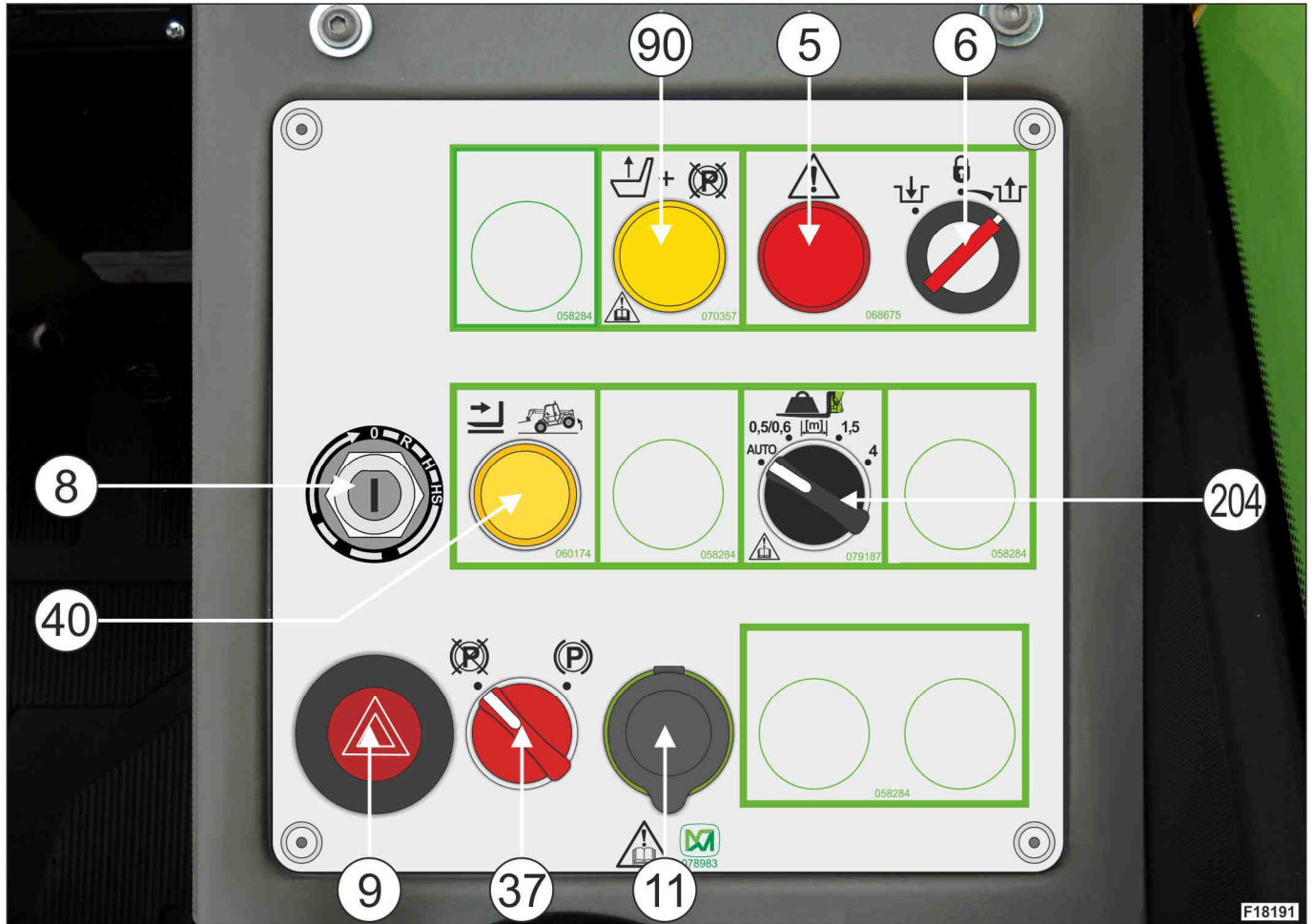

REF.	DESCRIPTION
5	Red warning light for anti-tilting exclusion
6	Working mode selector
8	Start key
9	Hazard lights switch (4 emergency flashing lights)
11	Portable light socket
37	Parking brake selector
40	Push button for retraction of the telescopic boom if the joystick has been damaged or during maintenance operations on the overturn system
90	Yellow warning light for hydrostatic transmission lock out
204	Switch for the selection of the attachment type installed on the machine



(P1) CONTROL PANEL KEY WORDS



REF.	DESCRIPTION
33	Cab roof indicator switch
36	Fan switch for cab heating
209	Indicator lamp showing that button (U) on the joystick is pressed (joystick enable button)
226	Adjustment buttons for instrument panel settings (C)

DASHBOARD KEY WORDS (C)

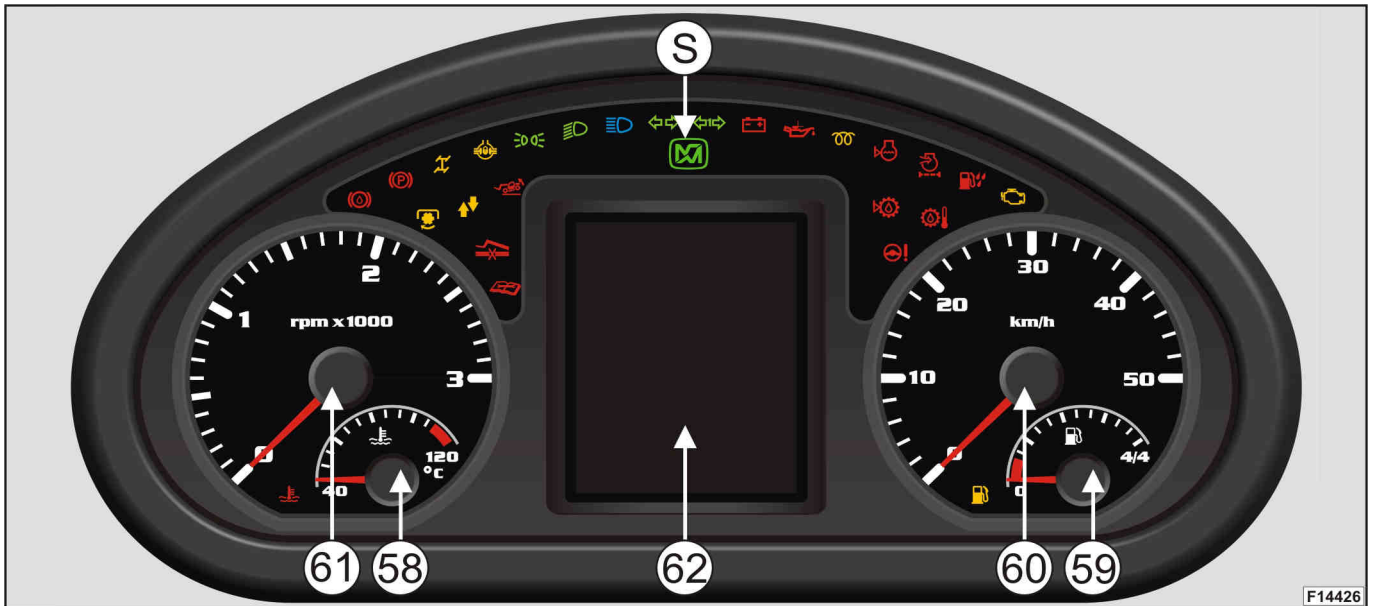

REF.	DESCRIPTION
58	Cooling liquid thermometer
59	Fuel level indicator
60	Speedometer
61	Engine RPM indicator
62	LCD display - Hour counter / Clock
S	Warning lights



DYNAMIC LOAD CONTROL DISPLAY KEY WORDS (D)



F15249

REF.	DESCRIPTION
210	Light bar indicating the stability percentage of the machine
S1	Display showing the operating functions of the machine
P1 – P2 – P3 P4 – P5	Selection buttons / setup

DIMENSIONS - P25.6

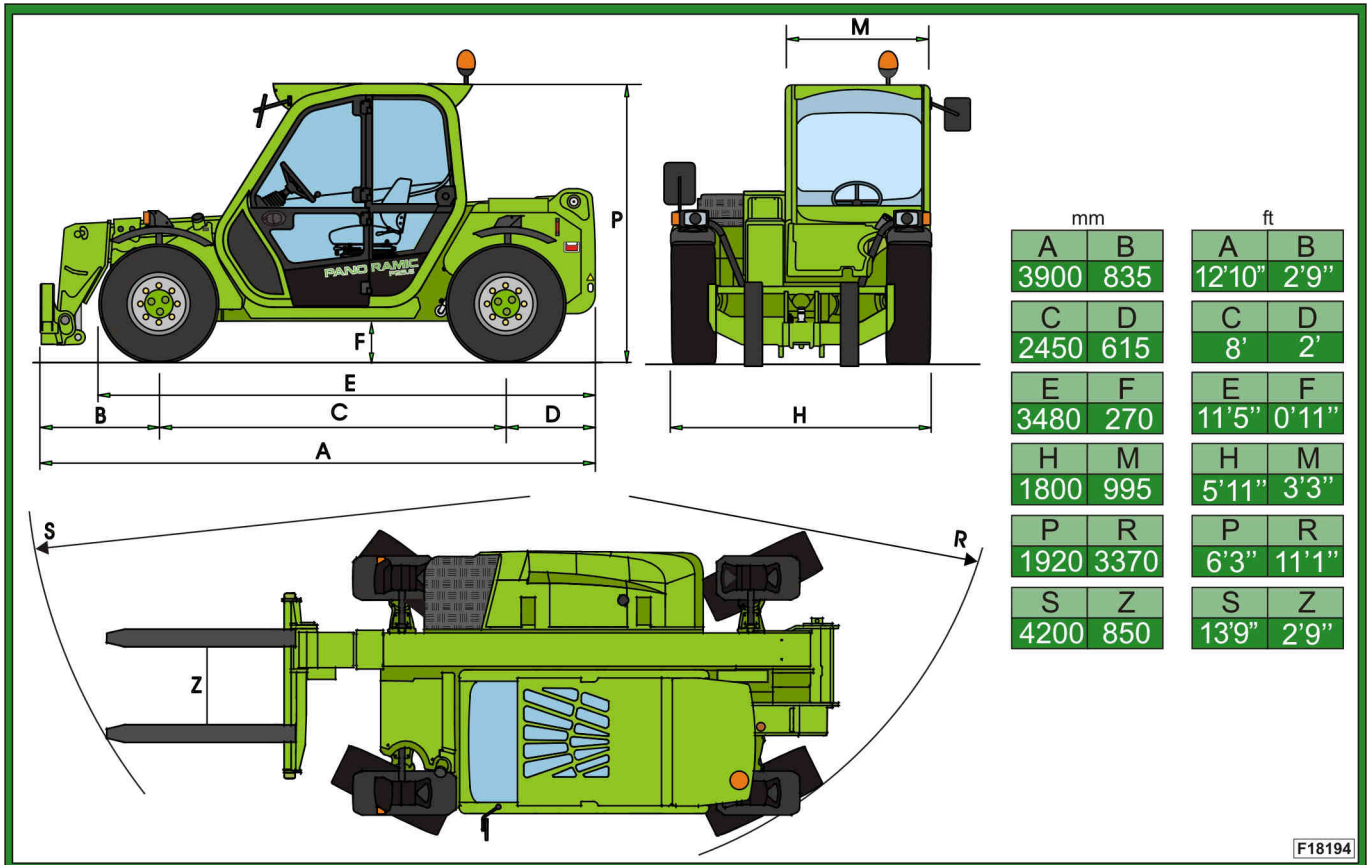

F18194



LOAD CHART

The load charts available on your machine, and shown in this manual, provide the different load capacity ranges of your machine when equipped with standard forks. The centre of gravity of the load being transported is calculated 600 mm away from the fork heel. Should other attachments be used in place of standard forks, please refer to the load charts contained in the document holder in the cab, and shown in chapter "ATTACHMENTS" of this manual.

For a better comprehension of the load chart, please refer to the example below:

- A) Maximum permitted slopes
- B) Indication of the telescopic boom lift height
- C) Name of the machine represented in the load chart
- D) Indication of the telescopic boom lift angle
- E) Indication of the extending boom sections (marked with letters)
- F) Description of the attachment installed on the carriage (forks in this case)
- G) M-CDC switch position
- H) Indication of the centre of gravity of the load being lifted
- L) Indication of the tyres to be used for this load chart
- M) Indication of the telescopic boom extension length
- N) Pick and carry informations

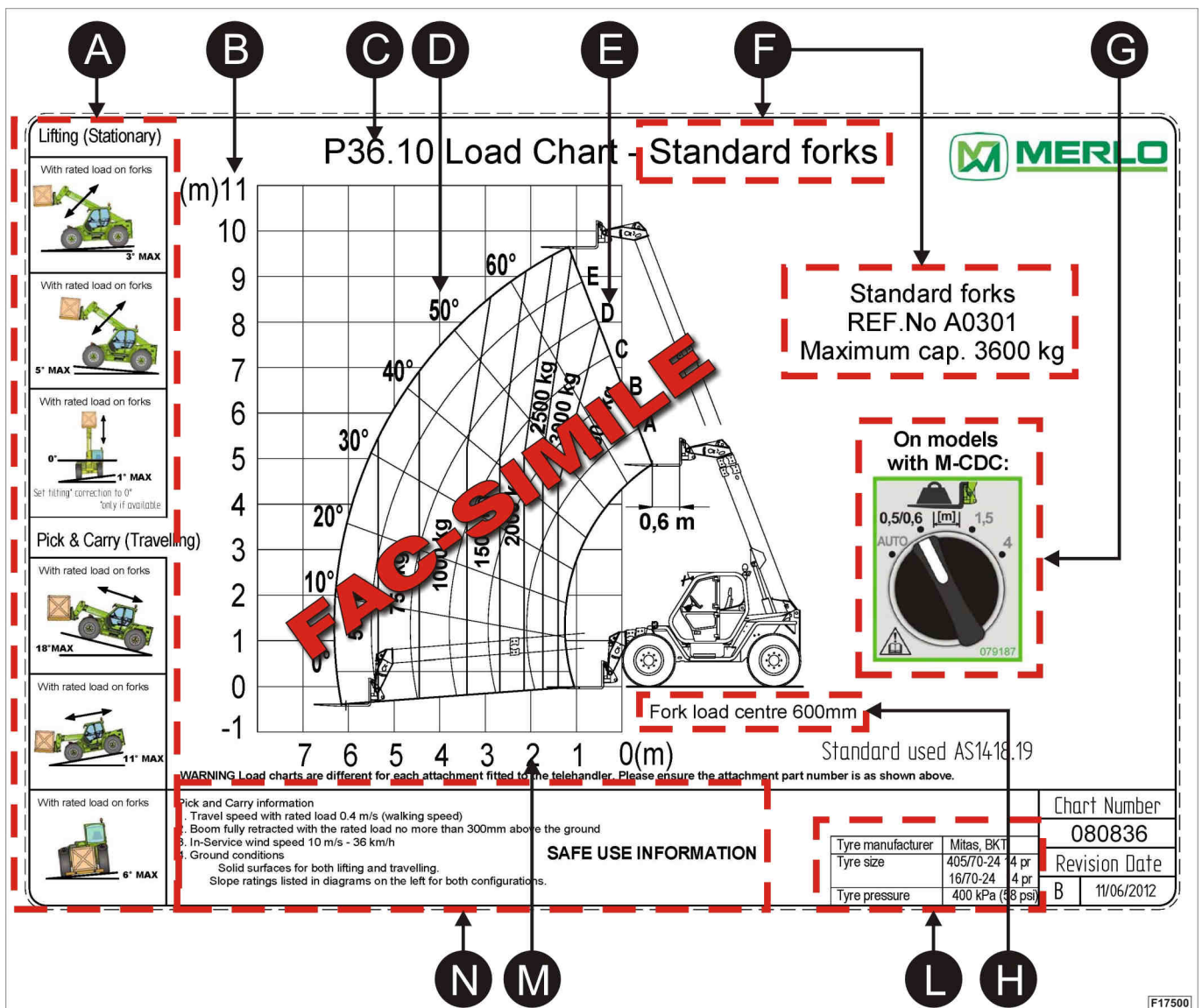

F17500



ATTENTION!

The load diagram for the machine on tyres refers to a machine that is standing still, with its wheels aligned to the chassis and positioned on a sufficiently even and solid ground.



***WARNING!** The list of authorised tyres which may be fitted to your machine is provided in the paragraph **FEATURES AND PERFORMANCES** in the **TECHNICAL DATA** section.*

If it is necessary to replace one type of tyre with another model (included in the list of authorised tyres), first contact Merlo's Technical Support service since replacing the tyres may also require replacement of the electronic control unit managing safety and load tables.



***WARNING!** For machines equipped either with platforms or with a factory-fitted wiring for platform installation, see the corresponding manuals to check whether or not there is a need for foam filled tyres.*

*Please note that machines with foam filled tyres **CANNOT** be driven on public roads.*



P25.6 Load Chart - Standard forks

Standard forks REF.No A0300
Maximum cap. 2500 kg

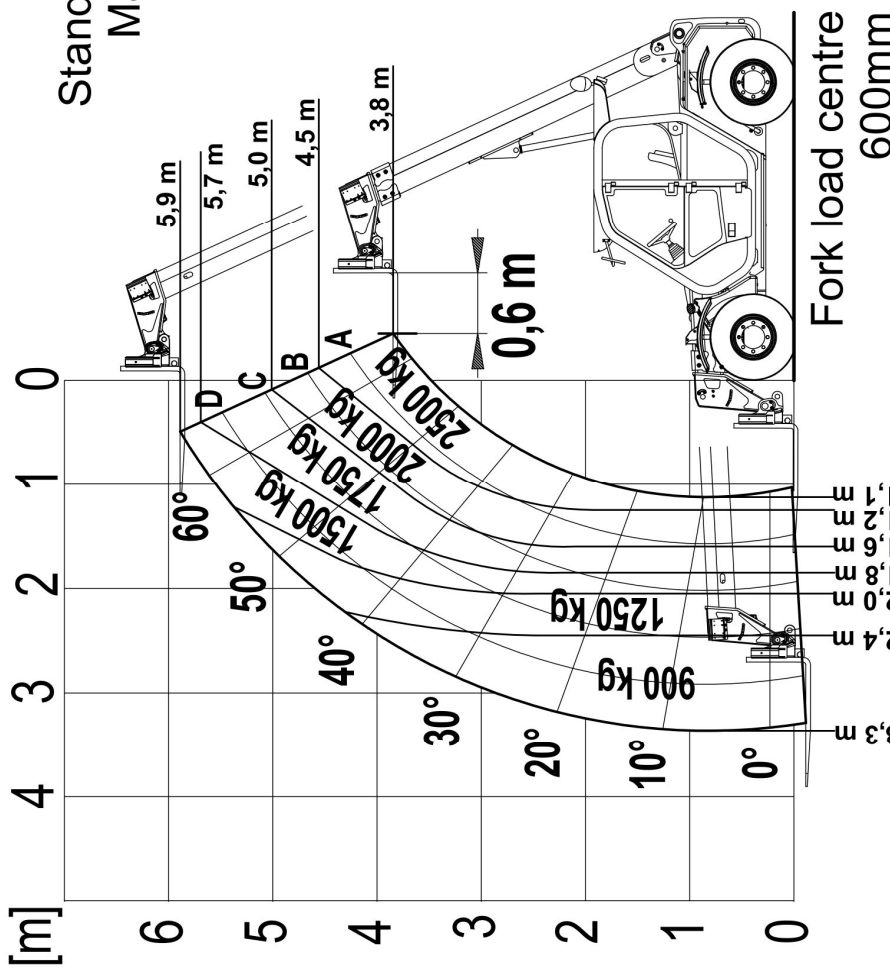

On models with M-CDC:

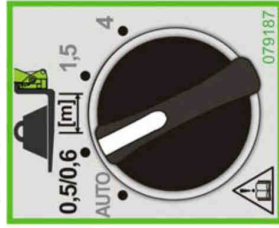

Standard used
AS1418.19

WARNING Load charts are different for each attachment fitted to the telehandler. Please ensure the attachment part number is as shown above.

- Pick and Carry information
1. Travel speed with rated load 0.4 m/s (walking speed)
 2. Boom fully retracted
 3. Rated load no more than 300mm above the ground
 3. In-Service wind speed 10 m/s - 36 km/h
 4. Ground conditions
- Solid surfaces for both lifting and travelling.
Slope ratings listed in diagrams on the left for both configurations.

<p>Lifting (Stationary)</p> <p>With rated load on forks</p> <p>3° MAX</p>	<p>With rated load on forks</p> <p>5° MAX</p>	<p>With rated load on forks</p> <p>3° MAX</p>
<p>Pick & Carry (Travelling)</p> <p>With rated load on forks</p> <p>18° MAX</p>	<p>With rated load on forks</p> <p>7° MAX</p>	<p>With rated load on forks</p> <p>6° MAX</p>

Chart Number	
085412	
Revision Date	
A	Febr. 2013

Tyre manufacturer	Mitas
Tyre size	12.0/75-18 12 pr
Tyre pressure	400 kPa (58 psi)

SAFE USE INFORMATION



PERFORMANCE AND FEATURES

The tables shown show data relative to a machine in its base/standard configuration.
Merlo Spa reserves the right to modify or amend machines/specifications without prior notification.

WEIGHT (kg)

MEASUREMENT CONDITIONS

- Machine in a basic configuration, without any attachments and variations
- Machine equipped with standard tyres
- Standard forks installed on the carriage
- Operator NOT in the cab
- Diesel oil tank empty

4750 (kg)

PERFORMANCE

Maximum load (kg)	Lift height (mm)	Maximum forward reach (mm)	Speed (Km/h) 1 st gear - 2 nd gear
2500	5900	3280	0-35(GOODEAR ; SUPERKING) 0-40 (MITAS)

ENGINE

Type KUBOTA V3307-DI-T-E3 / Turbo InterCooler / direct injection / water cooling
Power : 55,4 kW – (75 HP) at 2600rpm
Emission : low emission (EURO 3)

CABIN

In compliance with ISO 3449 (FOPS) and ISO 3471 (ROPS) standards
Mechanical joystick with ON-OFF button control of two movements

STEERING

Four drive/steer wheels with automatic wheel synchronisation
3 steering modes : normal, all wheel, crab

TRANSMISSION

Hydrostatic with hydraulic control

HYDRAULIC SYSTEM

Hydraulic system with gear pump

ELECTRICS

12 V
100 Ah battery
850 A-EN complete with manual battery isolator

CAPACITIES (litres or dm³)

Hydraulic system: 70

Fuel: 70

Hydrostatic oil 12

Engine oil: 11,2

Coolant: 6,2



TYRES

Reference	Pressure (Kpa)	Pressure Kg/cm ²
MITAS 12.0/75-18"12PR TR3	400	4,0

SERIAL NUMBER OF THE MACHINE

SERIAL NUMBER

The serial number of your machine is printed on the front right side of the chassis, and it is coated with a layer of black paint. When you either report a technical problem or place an order for spare parts, please provide Merlo Technical Support Service with both the serial number and the Sav number of your machine.

This code is made up of 17 characters, divided into 3 sectors, and shows you the manufacturing data of your machine.

An example of a serial number printed on a chassis is given below:

- chassis identification code: ZF1A28L01C1190883

ZF1: code that identifies MERLO S.p.A.

A28L01: model-specific code

C1190883 code that identifies the manufacturing decade (C= 2010-2019), the manufacturing year (1=2011), the manufacturing progressive number (1908), and the engine code (83)



IDENTIFICATION AND TYPE APPROVAL PLATES

- MACHINE IDENTIFICATION PLATE

The machine identification plate is placed in the rear left part of the cab and provides the operator with the following data:

- A - Kind of machine B - Sav number
- C - Maximum load capacity of the machine D - Overall machine weight
- E - Chassis number F - Manufacturing year

Spare parts shall always be ordered from Merlo Technical Support, by specifying the kind of machine, the Sav number and the chassis number.

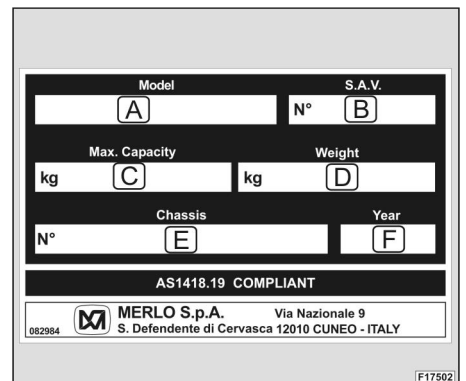

- ENGINE IDENTIFICATION PLATE

The engine identification plate is applied in the upper part of the engine, and provides you with engine data and specifications.

Should you need information, support, or original spare parts, please provide the engine Manufacturer with the data shown on the engine identification plate.

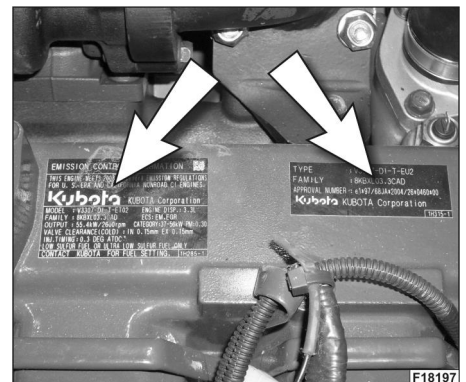



• CAB TYPE-APPROVAL PLATE GRCF01

Metal plate GRCF01 is applied inside the cab, on the electric box cover behind the driver's seat. This plate shows the cab type-approval data in compliance with the following international standards:

- ISO 3449: Falling object protective structures (FOPS)
- ISO 3471: Rollover protective structures (ROPS)

For further information please refer to paragraph "EC CONFORMITY", chapter "INTRODUCTION".



• AUTHORIZED ATTACHMENTS PLATE

(092476)

The authorized attachments plate is applied in the front left part of the cab and provides the list of authorized attachments for your machine.



TIGHTENING TORQUES FOR ISO METRIC THREADS

The tightening torque "Ma" of either a screw or a nut is the moment of a force required to put the screw under a certain initial tension. The tightening torque value is used to adjust the dynamometric wrench, as well as to prevent the screw from breaking due to fatigue. The following table shows the tightening torques "Ma" related to the external diameters of screws having metric threads. These are just indicative values, because the exact values depend on both the friction and the machining conditions of the screw supporting surfaces.



NOTE! This table refers to tightening applied slowly and with torque wrenches.

SIZE OF BOLT		TYPE OF BOLT								
		8.8			10.9			12.9		
		Nm	lbft	Kgm	Nm	lbft	Kgm	Nm	lbft	Kgm
COARSE PITCH	M3 x 0,5	1,8	1	0,18	2,6	2	0,27	3	2	0,31
	M4 x 0,7	3,1	2	0,32	4,5	3	0,46	5,3	4	0,54
	M5 x 0,8	6,1	4	0,62	8,9	7	0,91	10,4	8	1,06
	M6 x 1	10,4	8	1,06	15,3	11	1,56	17,9	13	1,82
	M7 x 1	17,2	13	1,75	25	18	2,55	30	22	3,06
	M8 x 1,25	25	18	2,55	37	27	3,77	44	33	4,49
	M10 x 1,5	50	37	5,1	73	54	7,44	86	63	8,77
	M12 x 1,75	86	63	8,77	127	94	12,95	148	109	15,09
	M14 x 2	137	101	13,97	201	148	20,49	235	173	23,96
	M16 x 2	214	158	21,81	314	232	32,01	368	272	37,51
	M18 x 2,5	306	226	31,19	435	321	44,34	509	376	51,89
	M20 x 2,5	432	319	44,04	615	454	62,69	719	531	73,29
	M22 x 2,5	592	437	60,35	843	622	85,93	987	728	100,61
	M24 x 3	744	549	75,84	1060	782	108,05	1240	915	126,4
M27 x 3	1100	812	112,13	1570	1159	160,04	1840	1358	187,56	
M30 x 3,5	1500	1107	152,91	2130	1572	217,13	2500	1845	254,84	
FINE PITCH	M8 x 1	27	20	2,75	40	30	4,08	47	35	4,79
	M10 x 1,25	53	39	5,4	78	58	7,95	91	67	9,28
	M12 x 1,25	95	70	9,68	139	103	14,17	163	120	16,62
	M14 x 1,5	150	111	15,29	220	162	22,43	257	190	26,2
	M16 x 1,5	229	169	23,34	336	248	34,25	393	290	40,06
	M18 x 1,5	345	255	35,17	491	362	50,05	575	424	58,61
	M20 x 1,5	482	356	49,13	687	507	70,03	804	593	81,96
	M22 x 1,5	654	483	66,67	932	688	95,01	1090	804	111,11
	M24 x 2	814	601	82,98	1160	856	118,25	1360	1004	138,63
	M27 x 2	1200	886	122,32	1700	1255	173,29	1990	1469	202,85
	M30 x 2	1670	1232	170,23	2370	1749	241,59	2780	2052	283,38

Nm = Newton-meter / lbft = pound - foot / kgm = kilogram - meter

END OF CHAPTER



INDEX

GENERAL REMARKS 2

INSIDE CAB STICKERS..... 2

OUTSIDE CAB STICKERS..... 4

LEAFLETS IN THE CAB..... 5

END OF CHAPTER 5



GENERAL REMARKS

All the stickers and the leaflets described in this chapter shall always be available on your machine; make sure that they are undamaged, and clean them periodically with a cloth dampened with a mild soap and water solution.

Should they be damaged or illegible, replace them with new original ones, to be ordered from Merlo Technical Support Service, and to be placed in the positions shown in the Operator's Manual.

Most of the symbols used are derived from International ISO 3287 and ISO 6405 standards. In any case, to avoid any misinterpretation, do not use the controls before having looked up the pertaining information contained in chapter "CONTROLS AND INSTRUMENTS".

INSIDE CAB STICKERS

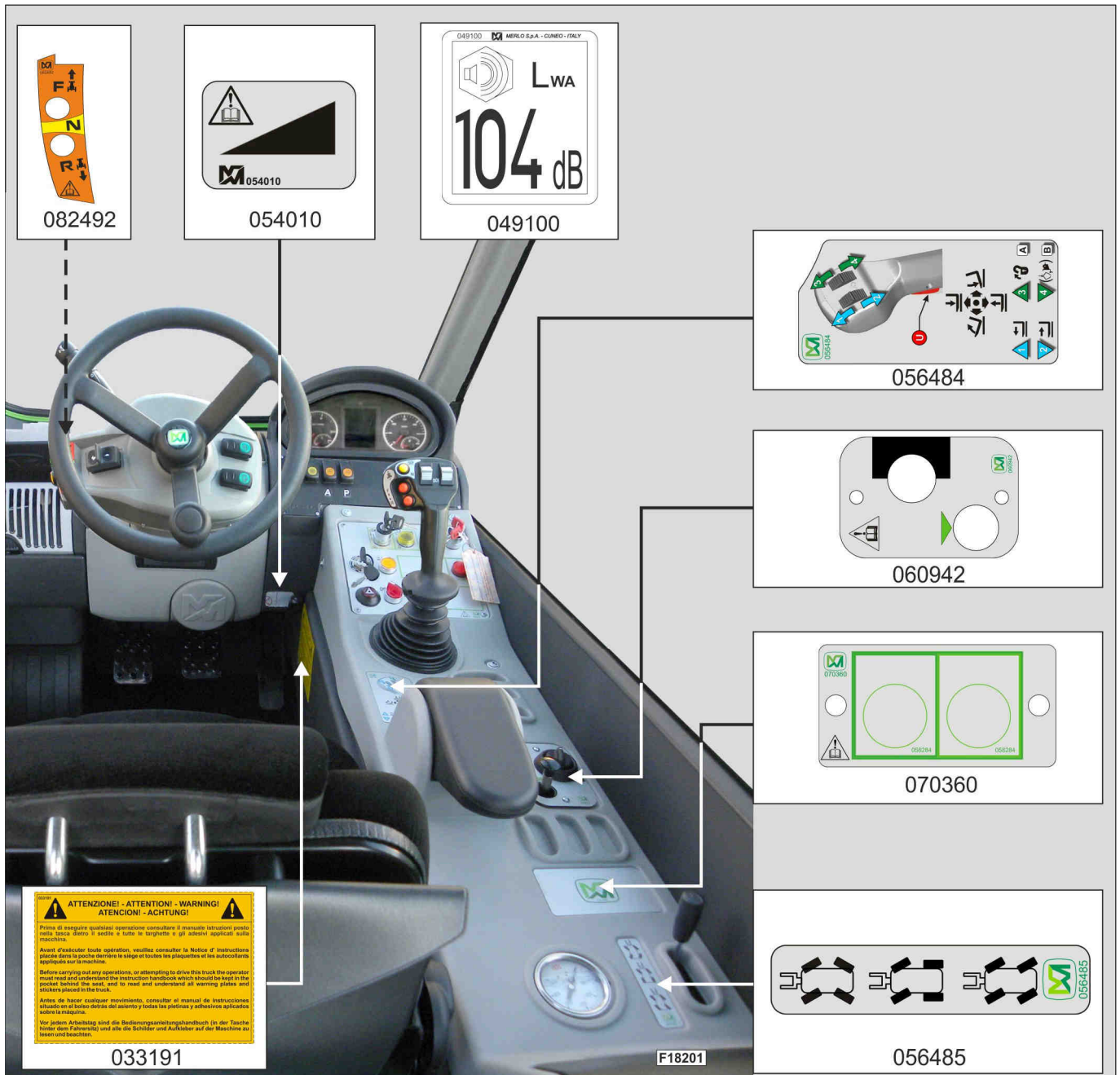



• STICKERS OF CONTROL PANEL (P)

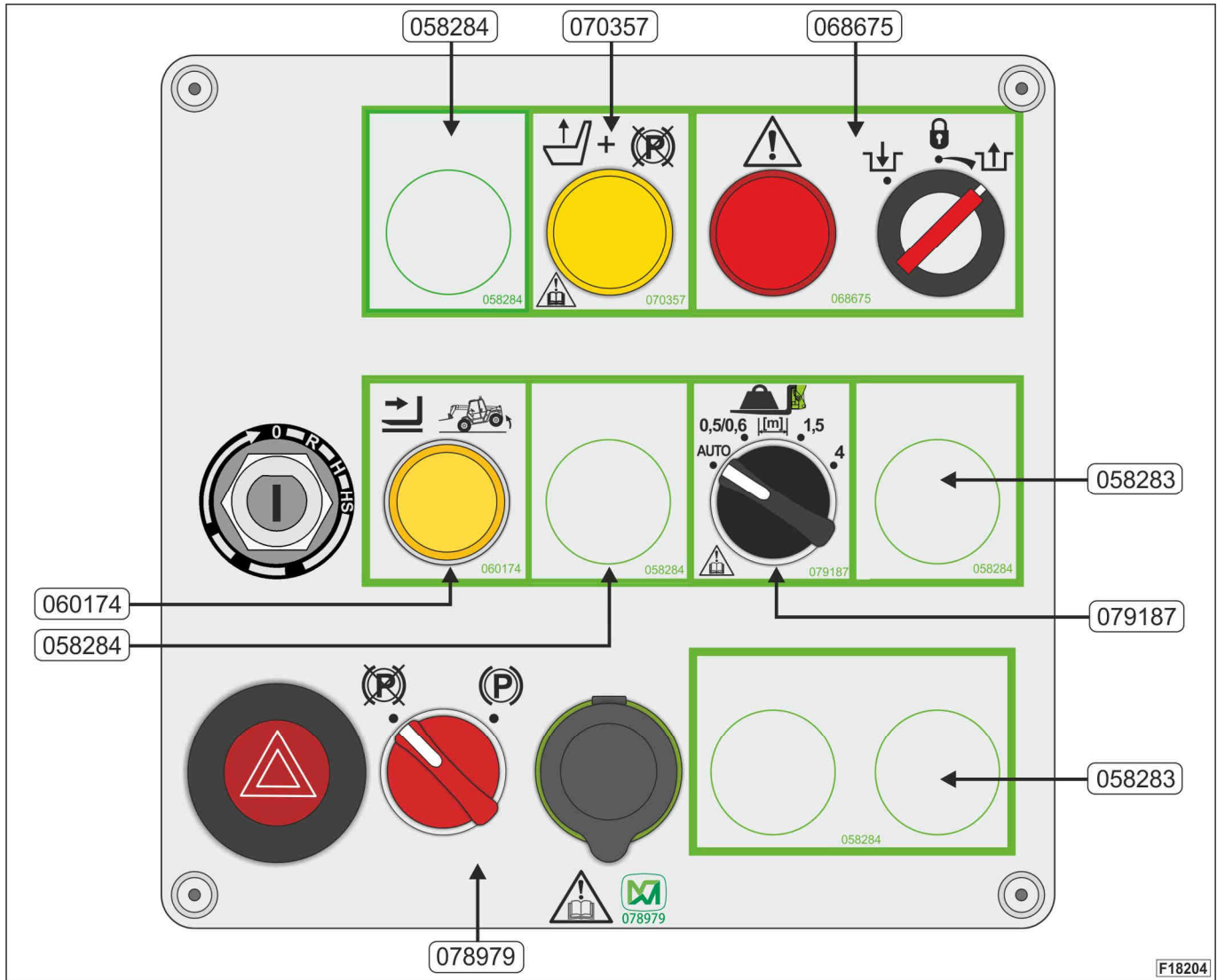

F18204



OUTSIDE CAB STICKERS

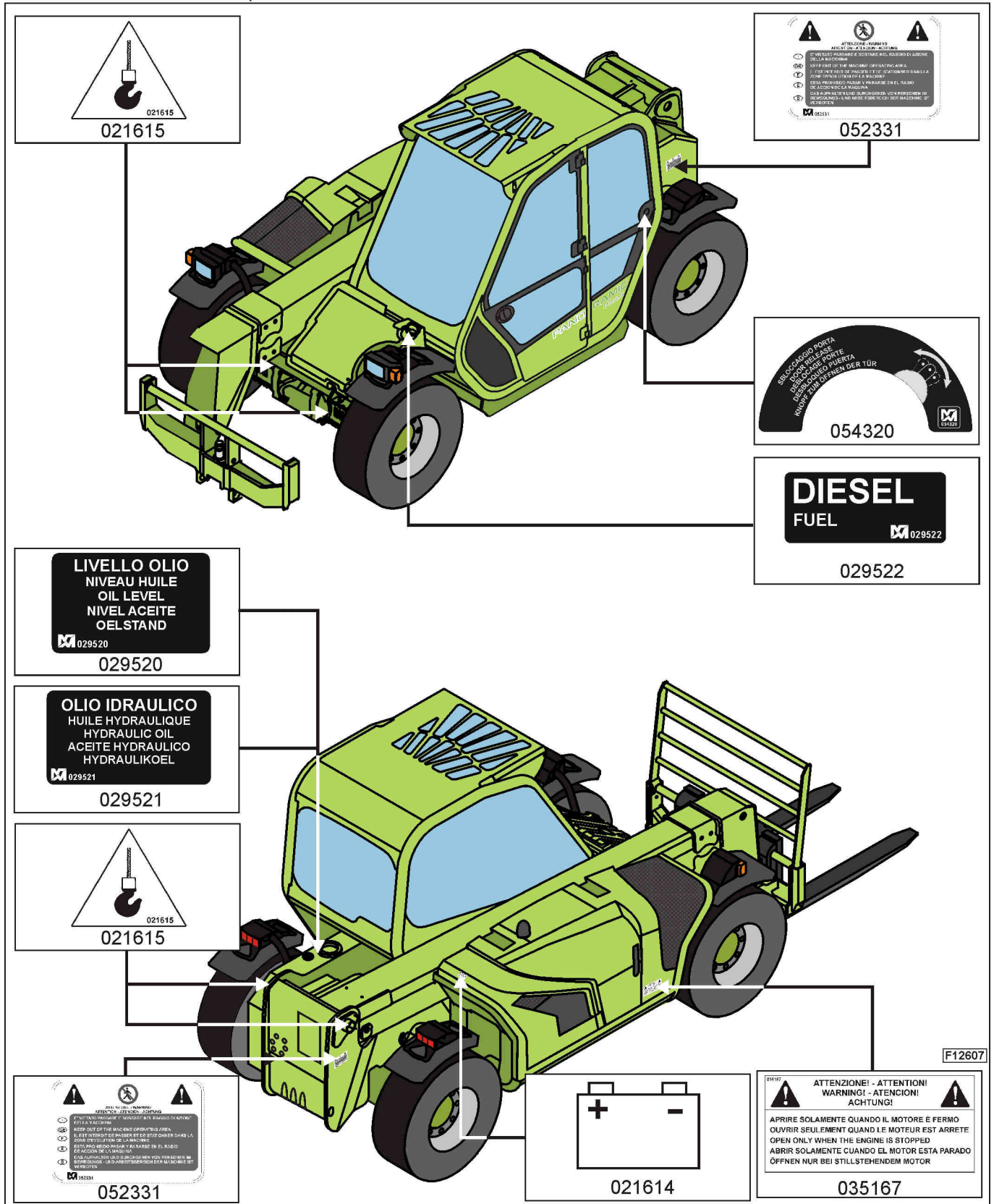



LEAFLETS IN THE CAB

The leaflets that provide information on your machine are contained in glove compartment (21) to the side of the steering wheel. These leaflets provide the operator with the main safety and operating instructions, which serve as a quick reference guide.

Always keep these leaflets in good condition. Should they be damaged, replace them with new ones, to be ordered from Merlo Technical Support Service.

To consult the leaflets in the cab, grab their protruding part, then lift it and rotate it towards you as shown in the picture (for further information please refer to paragraph "LOAD CHART HOLDER AND SAFETY INSTRUCTION CONTAINER", chapter "CONTROLS AND INSTRUMENTS").

This paragraph lists all the leaflets available on your standard machine; should you purchase any optional equipment, the corresponding leaflets will be made available in compartment (21).

END OF CHAPTER

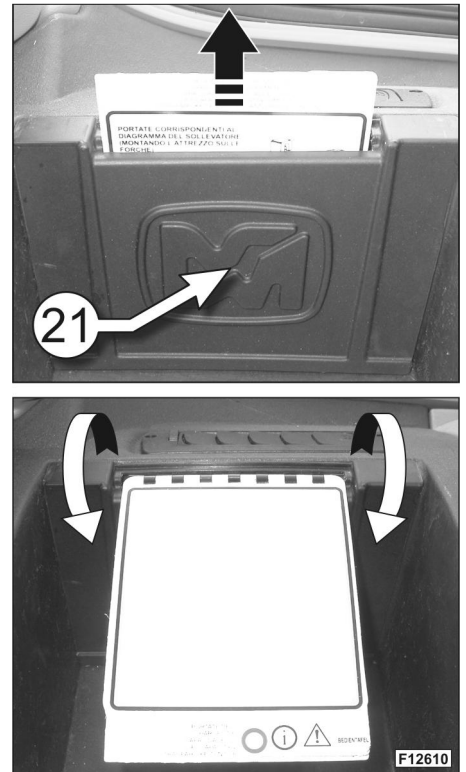



INDEX

GENERAL VIEW OF THE CAB.....	2
STANDARD SEAT.....	5
INSTRUMENT PANEL (C) DESCRIPTION	6
CONTROL PANEL (P) DESCRIPTION	10
CONTROL PANEL (P1) DESCRIPTION	11
DYNAMIC LOAD CONTROL SYSTEM (M-CDC)	12
ANGLE INDICATOR ON THE TELESCOPIC BOOM	24
TELESCOPIC BOOM CONTROL JOYSTICK AND SELECTION OF THE DRIVE DIRECTION (1).....	24
HYDRAULIC OR HYDROSTATIC SYSTEM PRESSURE GAUGE (12).....	25
PEDALS (14-15).....	25
LEVER FOR THE ADJUSTMENT OF THE STEERING WHEEL (17).....	25
FORWARD / REVERSE DRIVE SELECTOR (20)	26
LIGHTS AND HORN ON/OFF LEVER (24)	27
STEERING MODE (29)	28
WINDSCREEN WIPERS AND WINDSHIELD WASHER (34), (7)	28
HAND ACCELERATOR (86)	28
LATERAL AND LONGITUDINAL SLOPE INDICATORS	29
END OF CHAPTER	29

**GENERAL VIEW OF THE CAB**

• OPENING THE DOOR

In order to open the driver's cab door, release the lock by rotating the provided key "X" in clockwise direction, then act on handle "A" as indicated in figure (1).

• GETTING ON THE CAB

In order to correctly get on the cab, please follow these instructions:

- open the cab door
- look towards the machine and grab handles "A" e "B", located on the two sides of the cab (fig.2)
- use steps to access the cab



WARNING! While getting on the cab, only use the fitted supports (handles "A" and "B", non-slip steps). Do not grab any control (steering wheel, switches, instrument panel) to get on the driver's cab. Always keep clean and in perfect operating conditions the steps and handles to access the cab.

• CLOSING THE DOOR

Before using the machine, close the cab door by grabbing handrail "D" and firmly pulling towards the inside (fig.3).



WARNING! The lower part of the driver's cab must always be closed, both during transfers with the machine and when working.

• OPENING THE CAB DOOR FROM THE INSIDE

To open the cab door from the inside, simply pull lever "E" (fig.4) towards the direction shown by the arrow

• GETTING OFF THE DRIVER'S CAB

To get off the cab, it is again necessary to use the appropriate supports (handles "A" and "B"). Remember to carry out such operations while always looking towards the inside of the machine.

• CLOSING THE CAB DOOR

After getting off the driver's cab, always close the door. In case of a prolonged stop or at the end of each working day, it is recommended to close the cab door and lock it with the provided key, so as to prevent any unauthorised tampering. To close the cab door, rotate the provided key "X" in anti-clockwise direction.

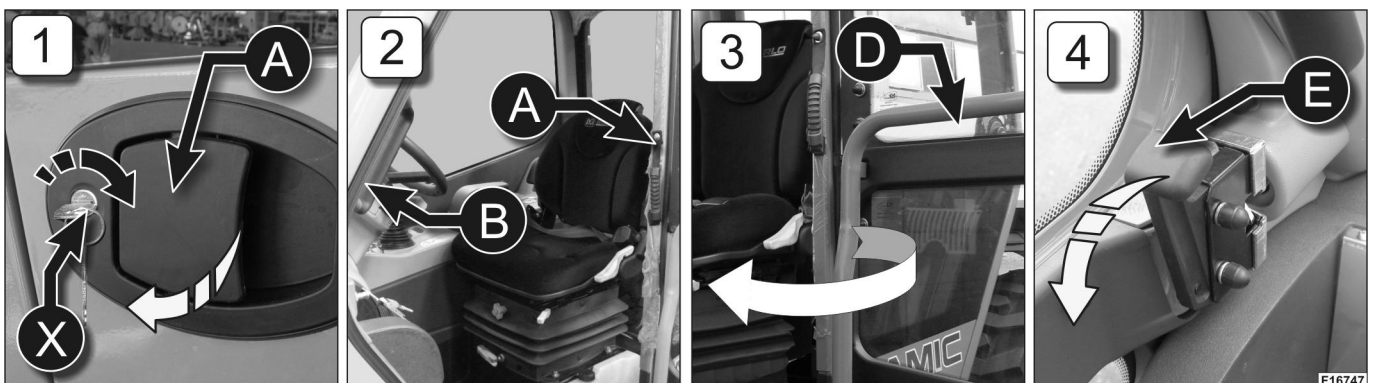

• FIRE EXTINGUISHER INSTALLATION IN THE CAB



WARNING!
The person in charge (owner, responsible of the building site, etc.) must check whether it is necessary to mount a fire extinguisher inside the cabin.



• OPENING THE DOOR UPPER PART

To open the upper part of the door, proceed as follows:

- rotate handle "A" upwards (direction indicated by the arrow) (fig.5)
- completely open the upper part of the door and hook it to the appropriate external device "B" (fig.6)

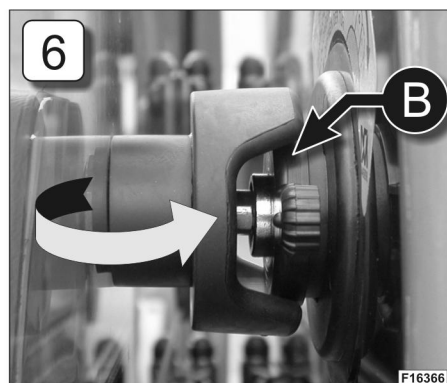
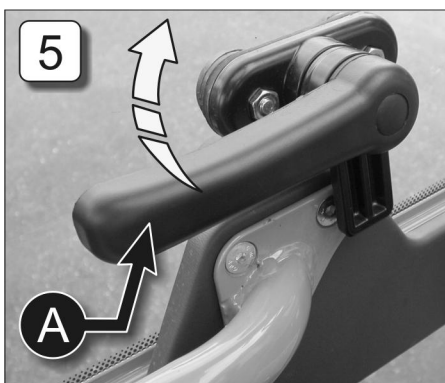

WARNING! Please remember that the lower part of the door must be closed both during transfers with the machine and when working.

• CLOSING THE DOOR UPPER PART

To close the upper part of the door, proceed as follows:

- from the inside of the cab, release stop "B" by acting on its tongue "C" (fig.7)
- from the outside of the cab, release stop "B1" by acting on its tongue "C1" (fig.8)
- completely close the upper part of the door and lock it into position by rotating handle "A" downwards (in the direction shown by the arrow) (fig.9)

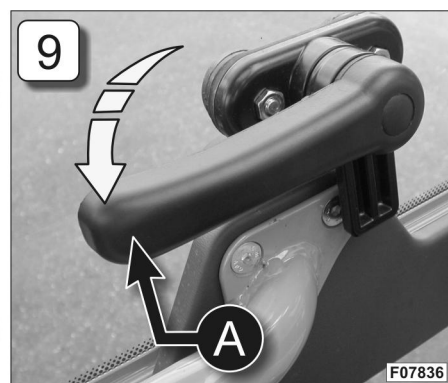
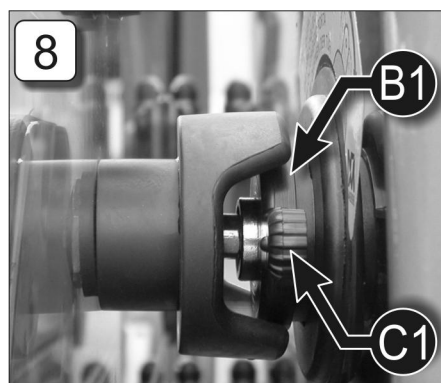
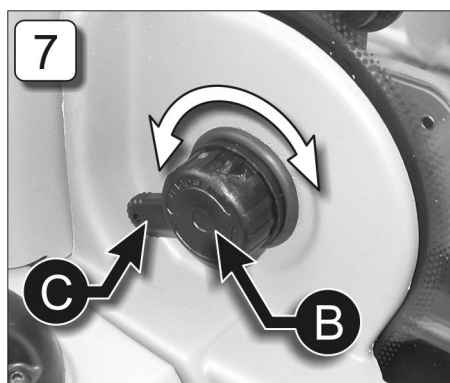

WARNING! Before starting operating with the machine, the operator must ensure that the upper part of the door cannot accidentally open.

• EXIT FROM THE CAB IN CASE OF AN EMERGENCY

If it is not possible to leave the vehicle using the cab door, it is necessary to use the emergency exit:

FRONT WINDOW (A)

- Remove the fixing pivot "P" by pulling in direction indicated
- Fling the front window "A" open then go out of the cab very cautiously.

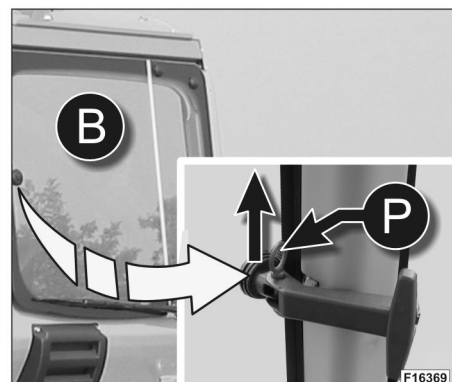
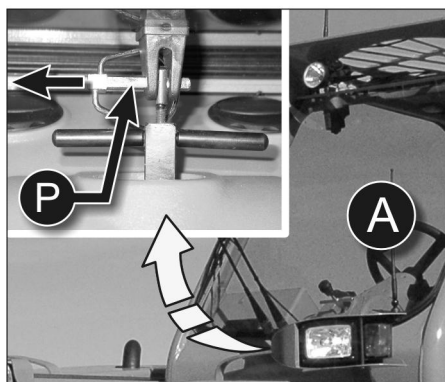

REAR WINDOW (B)

- Remove the fixing pivot "P" by pulling in direction indicated
- Fling the rear window "B" open then go out of the cab very cautiously.



• WINDSCREEN OPENING

- turn the lever "A" through 45°
- open a little the windscreen
- move the lever "A" in horizontal position
- push the windscreen forward up to the automatic stop position.

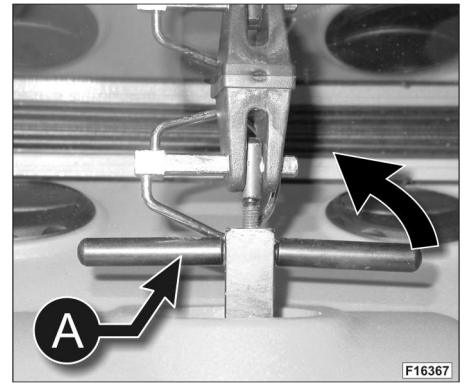

• WINDSCREEN CLOSING

- turn the lever "A" through 45°
- close a little the windscreen
- move the lever "A" in horizontal position
- close the windscreen by pulling it backwards up the the rest position.

• REAR WINDOW OPENING

Rotate the lever (A) on the left side, then open the window pushing it forward to the desired position.

• REAR WINDOW CLOSING

Rotate the lever (A) on the side to the automatic stop position.

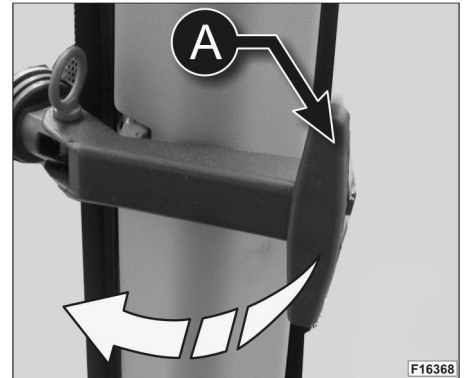

• CAB LIGHTS

The cabin internal courtesy light "P" is located in the right upper part of the roof lining.

The light has 3 positions:

- a) left position: light off
- b) central position: light off
- c) right position: courtesy light on

It is possible to switch on the cabin courtesy light even when the instrument panel is switched off

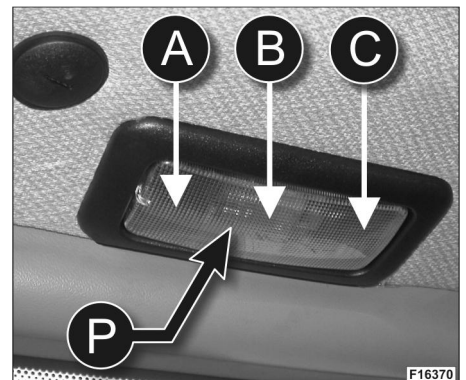

INTERIOR COMPARTMENT VENTILATION

The cab ventilation is granted by the outlets present on the dashboard and under the seat. Press to lift fins, then adjust the outlet in the desired position.

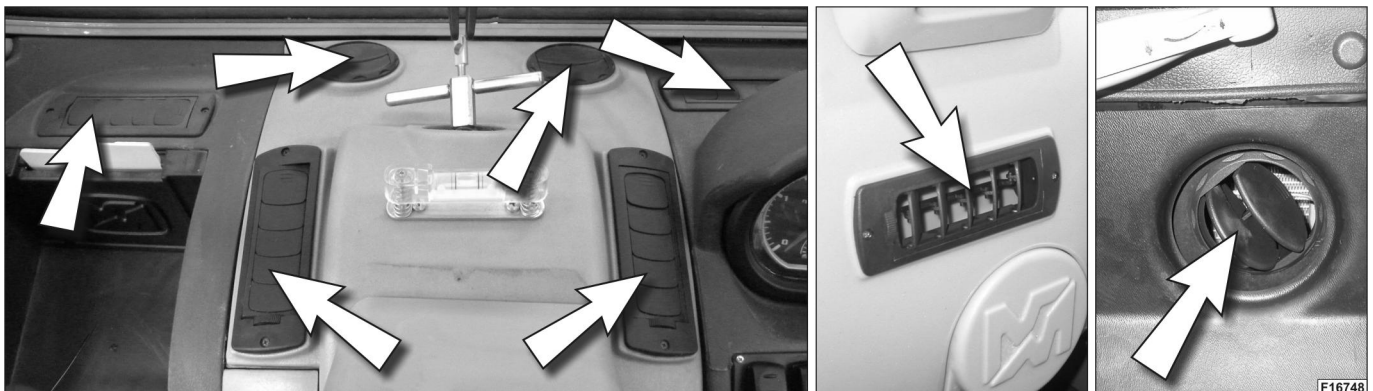



STANDARD SEAT

The instructions for the proper use of the driver's seat, described in this paragraph, refer to the standard model mounted on your machine. If your machine is equipped with a seat different from the standard one, please refer to the relevant instructions in Chapter "OPTIONAL EXTRA".

SEAT SHIFT (1)

Lift lever "M", slide the seat forwards or backwards to obtain the required position and release the lever.

HEIGHT ADJUSTMENT (2)

Sit on the seat and use knob "I" to adjust to the required height; turn the knob to direction "+" to raise the seat or in direction "-" to lower it.

SUSPENSION ADJUSTMENT (3)

To adjust the seat suspension use handle "A" located at the front side of the seat frame. Sit on the seat and turn the handle until just the right degree of suspension is achieved for one's weight. (direction "R" to tighten the suspension, direction "S" to slacken the suspension)

BACK ADJUSTMENT (4)

Sit with your back firmly against the seat back. Lift lever "L" upwards to position the back to the required angle.

DOCUMENT HOLDER POCKET (5)

Located behind the seat for holding the machine documentation and small objects.



WARNING! It is forbidden and it is extremely dangerous to adjust the driver's seat while the vehicle is moving. Position the driver's seat so that the driver can easily reach the vehicle controls. Always keep the "INSTRUCTION HANDBOOK FOR OPERATING AND MAINTENANCE" in the document holder pocket (5).

SAFETY BELT

Seat correctly in the driving seat and check that the safety belt is not kinked. Fasten correctly the safety belt as shown in the picture.



ADJUSTMENT



LOCKING



RELEASE



WARNING ! Before operating the machine always fasten the seat belt and close the lower part of the door whether machine is stationary or moving.. Adjust the safety belt so that it lays on your hips and not on your stomach.

**INSTRUMENT PANEL (C) DESCRIPTION**

The dashboard of your machine shows the following information:

- ANALOGIC REV COUNTER (61)

The analogic rev counter shall be used to:

- control the engine running speed
- adjust the engine speed when using manual lever (86) (see related paragraph)
- carry out maintenance operation (by skilled staff)

- ANALOGIC TACHOMETER (60)

The analogic tachometer shall be used to control the driving speed during on-road transfers.

**WARNING!**

Always respect the applicable laws on road circulation in the country where the machine is used.

- ENGINE COOLING LIQUID TEMPERATURE INDICATOR (58)

When using the machine, periodically check the engine cooling liquid temperature. If it reaches its maximum limit (indicated by a red line and by the yellow light indicator switched on) immediately turn off the engine and wait for it to cool down.

Also check the engine cooling liquid level, as indicated in chapter "PERIODIC MAINTENANCE".

- FUEL LEVEL INDICATOR (59)

This instrument indicates the fuel level inside the tank. When filling up the tank, only fill up with the fuel indicated by standard EN590.

For further information, refer to paragraphe "FUELS AND LUBRICANTS".

- LIGHT INDICATORS ON THE DASHBOARD

The dashboard contains light indicators of several colours, which show the operator:

- the activation of a control (green light or blue light on)
- the activation of a device which requires particular attention in its operation (yellow light on)
- the presence of an alarm (red light on and sound alarm emitting a continuous sound)

Here are listed and described the light indicators found on the dashboard:





REF.	DESCRIPTION
44	Battery charging With the engine running, the alternator cannot charge the battery correctly.
45	Engine oil pressure Insufficient oil pressure in the engine. This warning light illuminates above 1,000 rpm with low engine oil pressure. In this condition stop the engine immediately and fill up oil. Start the engine again, and see if the warning light switches off. If the problem persists, please contact the Merlo Technical Support Service.
46	Brake oil level Insufficient brake oil level. Stop your machine and search for the cause of the problem. Fill up specific oil.
47	Engine air filter clogged The engine air intake filter is clogged. Clean the filter. Replace it if necessary.
48	Hydrostatic transmission oil level Insufficient oil level in the hydrostatic transmission. Stop your machine and search for the cause of the problem. Fill up specific oil.
49	Hydrostatic transmission oil temperature High oil temperature in the hydrostatic transmission. Stop your machine and search for the cause of the problem.
50	Low-beam headlights Low-beam headlights on. Obey the highway code of the country you are driving in.
51	High-beam headlights High-beam headlights on. Obey the highway code of the country you are driving in.
52	Blinkers Blinkers are on in an intermittent mode.
53	Glow plug pre-heat indicator Preheating of spark plugs for cold engine start
54	Front overturn prevention system The front overturn prevention system is activated, and all controls are disabled.
55	Crab steering Crab steering is engaged; proceed with particular caution during transfers.
56	Chassis side-shift (not applicable to this model)
57	Parking brake When the drive direction selector is in a neutral position, the parking brake is applied. If this malfunction is shown even after the parking brake is released, this means that pressure in the system has dropped below the minimum allowable value (about 18 bar).
87	Engine malfunction (not applicable to this model)
88	Differential locking device The differential locking device (available as an option) is engaged.
93	Engine coolant temperature The engine coolant temperature is too high. Switch off the engine and let it cool down. Check the coolant level inside the expansion tank.
96	Tail lights Tail lights on. Obey the highway code of the country you are driving in.
103	Rear PTO (not applicable to this model)
108	Fuel reserve indicator Low fuel level in the tank. Fill up.
132	Coolant level Fill up the engine cooling system with the engine coolant prescribed by the engine manual.
133	Water in the diesel oil (not applicable to this model)
205	Direction indicators failure for agricultural trailer (available as an option)
206	Break in the rope for telescopic boom extension (not applicable to this model)
207	Merlo Service reminder (not applicable to this model)
208	Malfunction of the hydraulic steering system (not applicable to this model)

**WARNING!**

For further information on the dashboard light indicators, refer to chapter "OPERATING INSTRUCTIONS".



- LCD DISPLAY (62)

When the engine is not running display (62) is off (Fig.1). To set some functions of the LCD display use the (OK) and (C) buttons on the instrument panel (P1). The LCD display provides the operator with the following information:

- date and time (Ref.2)

The current date and time are shown in the upper part of the LCD display. To set these data manually, please refer to the following instructions:

- press the (C) button for about 3 seconds; the time starts flashing. Release the (C) button, then press the (OK) button to set the time. If the (OK) button is pressed briefly, time digits decrease, while if the button is held they increase rapidly until the button is released. To set other data (minutes, day, month, year) press the (C) button, then proceed in the same way as for time setting

- partial and total hour counter (Ref.3)

The lower part of the LCD display (62) shows either the total/partial hour counter data (divided by an hourglass-shaped indicator in the middle) or the trip/total kilometres odometer data (divided by an indicator with the "km" inscription). To switch from one setting to the other press the (C) button.

The partial hour counter shows the number of machine operating hours since the latest resetting. The maximum value the counter can show is 999.99 hours; after that it starts from 0.0 again. To reset the partial hour counter press the (OK) button for 3 seconds.

The total hour counter shows the total number of machine operating hours (the counter starts working after engine start). The maximum value the counter can show is 999,999 hours; after that it starts from 0 again.

- trip/total kilometres odometer (Ref.4)

The lower part of the LCD display (62) shows either the trip/total kilometres odometer data (divided by an indicator with the "km" inscription) or the total/partial hour counter data (divided by an hourglass-shaped indicator in the middle). To switch from one setting to the other press the (C) button.

The trip odometer shows the number of kilometres travelled by the machine since the latest resetting. The maximum value the odometer can show is 999.99 kilometres; after that it starts from 0.0 again. To reset the trip odometer press the (OK) button for 3 seconds.

The total kilometres odometer shows the total number of kilometres travelled by the machine (the odometer starts working after engine start). The maximum value the odometer can show is 999,999 kilometres; after that it starts from 0 again.

- selected drive direction (Ref.5)

The system graphically represents the selected drive direction (either forward or reverse), and shows it on display (62) as follows:

- A) forward drive selected
- B) reverse drive selected

Drive direction can be selected with control lever (20). For further information please refer to paragraph 'DRIVE DIRECTION SELECTOR' in this chapter.

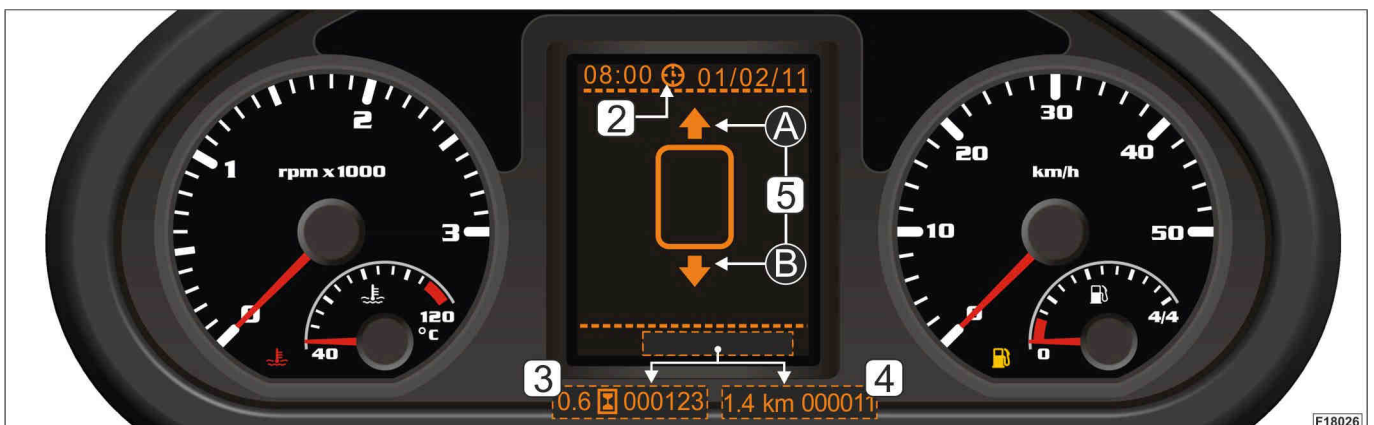



• malfunction display

Any malfunction detected in the machine is made known to the operator by switching on the corresponding control indicator in fields (A) of the LCD display (62).

For some of these malfunctions the corresponding warning lights in the upper part of the instrument panel switch on too. In such cases, please follow the instructions provided in the table in paragraph "WARNING LIGHTS ON THE INSTRUMENT PANEL".

The following table shows all possible malfunctions that can be displayed:

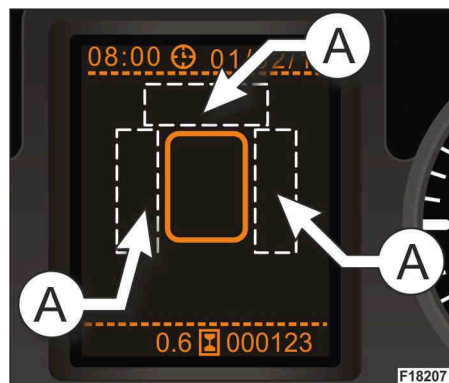

WARNING LIGHT	FAULT DESCRIPTION	SWITCH ON MODE	AUDIBLE ALARM
	Engine coolant level Function corresponding to warning light (132)	Flashing	Intermittent
	Engine coolant temperature Function corresponding to warning light (93)	Steady	No
	Hydrostatic transmission oil temperature Function corresponding to warning light (49)	Steady	No
	Hydrostatic transmission oil level Function corresponding to warning light (48)	Steady	No
	Brake oil level Function corresponding to warning light (46)	Steady	No
	Parking brake alarm With the engine running and the parking brake applied, the forward/reverse drive is selected.	Flashing	Intermittent
	Front overturn prevention system control Function corresponding to warning light (54)	Steady	No

• display of info messages

The middle part of the LCD display (62) shows some info message icons which inform the operator that he's carrying out unallowed manoeuvres. The info message icons are the following:

- Starting the engine inhibited with the direction control (20) set to "F" or "R" (Fig.7a)
- Starting the engine inhibited with the rear power take-off engaged (not active on this model) (Fig.7b)
- Direction control (20) inhibited with parking brake active (Fig.7c)
- Direction control (20) inhibited because there is no operator in the driver's seat (Fig.7d)

When the info message icons appear on the LCD display (62), the buzzer goes off at the same time, and emits a continuous tone.

To clear the info message icons from the LCD display (62) you can either:

- press the "OK" button (acknowledgement). The window is disabled, but the problem persists;
- carry out the maintenance needed to fix the malfunction.

After carrying out these operations, the info message window is closed and the diesel engine can be started.

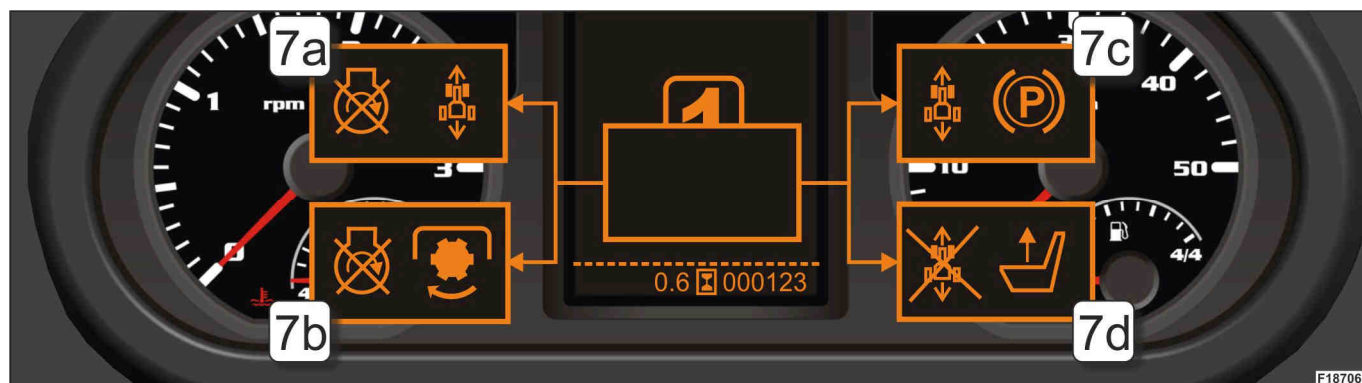



CONTROL PANEL (P) DESCRIPTION

• WORKING MODE SELECTOR (6)

On delivery this key can be found in the Operators Manual wallet, in the back of the seat. It is important to understand its use, before using this key:

- A) Movements enabled.
Personnel or material lifting. The machine can be used as a lifting device (installing the forks, the fly jib, etc.). The key must be removed.
- B) Road travel.
All controls of the hydraulic circuit are disabled with the exception of the steering. This function should be used to prevent any accidental operation of controls during road travel.
When this operating mode is selected, the system switches off display (D) in the cab.
- C) Emergency movements (control with a spring return to the "B" position)
The "C" position of selector (6) gives you all necessary movements to restore transportability conditions in case of failure of one of the safety devices.
In the time span when emergency movements are enabled warning light (209) on control panel "P1" switches on in a steady mode, red warning light (5) on control panel "P" switches on in an intermittent mode, while the audible alarm remains off.
The safety device bypass function can be enabled in any configuration or operating condition of your machine

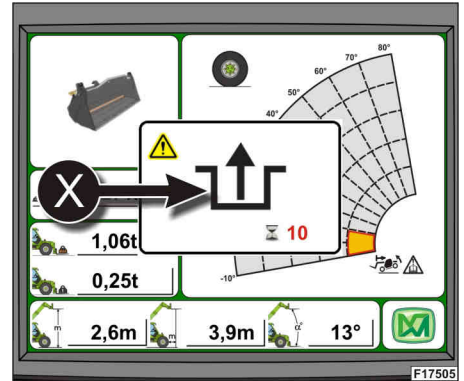
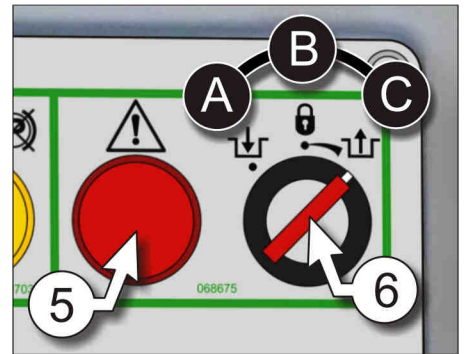

NOTE! To enable the emergency controls on your machine you need to turn selector (6) to position 'C' and hold it in that position. Then you have 10 seconds to carry out all necessary manoeuvres to restore safe operating conditions. This function is shown on display (D) in the cab with information window 'X', containing the 'emergency movements' symbol and a timer with a count-down feature.

After these 10 seconds the system disables all emergency movements and automatically re-enables the overturn prevention system on your machine. To be allotted another 10 seconds you need to release selector (6) and then repeat the command.



WARNING! Correct and safe use of the isolation system is ultimately the responsibility of the person in charge of the operation (e.g. owner, site manager). You are advised to keep the key in a safe place, in order to prevent its incorrect and unsafe use. It is only possible to extract the key with the selector (6) in "A" position.

• IGNITION KEY (8)

- 0 = engine off
- R = dash board lights on
- H = spark plug heating
- HS = engine start

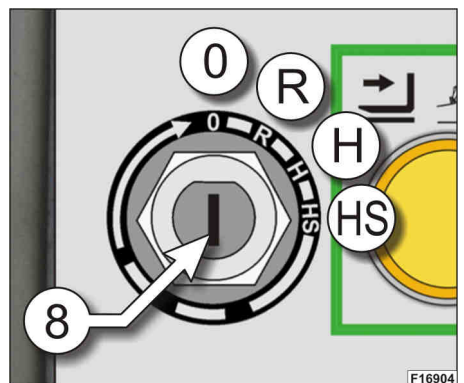

• EMERGENCY LIGHTS (9)

HAZARD WARNING LIGHT SWITCH

Push the switch to operate the 4 emergency lights (it can be used also with the starting key in position 0).

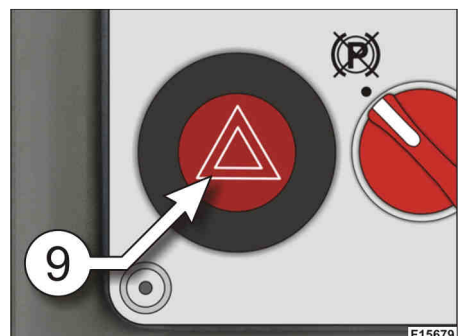



- SOCKET FOR TROUBLE LIGHT (11)

The shown socket (11) can be used to feed a trouble light equipped with connection for electric lighter. Use a 12 V and max. 40 W lamp.

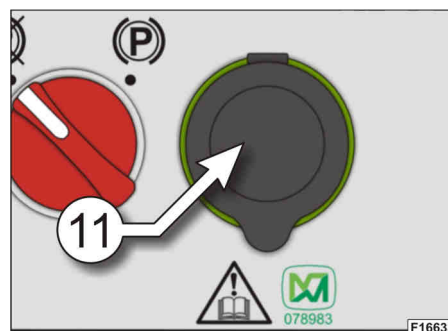

- HAND BRAKE (37)

With engine running:

- Turn the (37) selector towards right to engage hand brake (the selector lights)
- Turn the (37) selector towards left to release hand brake (the selector stop lightening)

Whenever the engine stops, the parking brake remains engaged independently from the selected condition.

The emergency pump (28) must be used only to release the parking brake before towing the vehicle.



WARNING!

The machine is equipped with a reversing alarm system that activates an intermittent audible warning signal if "F" or "R" drive is selected (20) when the parking brake (37) is activated.

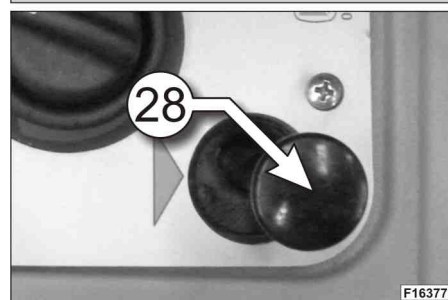
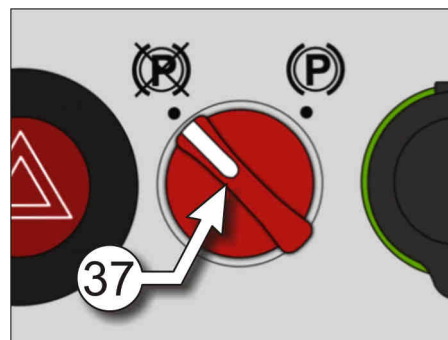

- LOCK OUT OF THE HYDROSTATIC TRANSMISSION (90)

Should the operator decide to get off the cab while the engine is still running and the parking brake is not applied, the machine automatically enters a safe mode, and locks out the hydrostatic transmission.

In order to use the hydrostatic transmission again to move the machine forward/backward, the operator shall sit correctly in the driver's seat in the cab.

Should the operator decide to get off the cab while the diesel engine is still running and the drive direction selector (20) is in position "F" or "R", the selector (20) shall be shifted to neutral position "N" first and then in the desired direction to restore the normal operation of the hydrostatic transmission.

Should the operator forget to apply the parking brake before getting off the cab, a yellow intermittent light (90) will inform him/her of his/her oversight.

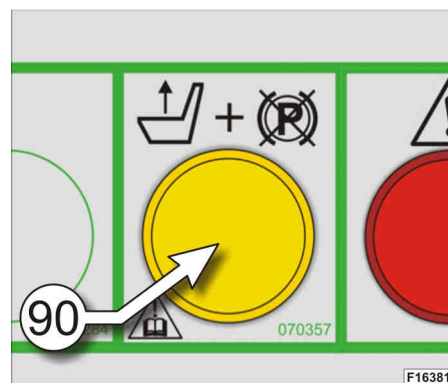

NOTE! For a safe and correct use of your machine, please note that before getting off the cab you need to:

- shift the drive direction selector (20) to neutral position "N"
- apply the parking brake (37)
- switch off the diesel engine of your machine
- get off the cab and close the cab door.

The automatic lockout of the hydrostatic transmission described in this paragraph is to be considered an exception to the rule.

CONTROL PANEL (P1) DESCRIPTION



• HEATER (35)

HEATER CONTROL KNOB (ITEM 35)

- A = increase temperature
- C = decrease temperature

CAB HEATING FAN SWITCH (REF. 36)

The switch has three positions:

- 0 fan off
- 1 fan on, at speed 1
- 2 fan on, at speed 2



Never place any objects behind the seat which may obstruct the air inlet of the ventilation system.

SELECTION OF THE AIR SUCTION FROM INSIDE/OUTSIDE THE CAB

To select the air suction mode, operate on the relevant control reference "R", placed behind the seat, as follows:

- lever in "A" position (suction grid "C" not visible): air suction from the outside of the cab
- lever in "B" position (suction grid "C" visible): air suction from the inside of the cab (recirculation)



Do not put any object that could obstruct the air inlet of the ventilation system "C" behind the seat.

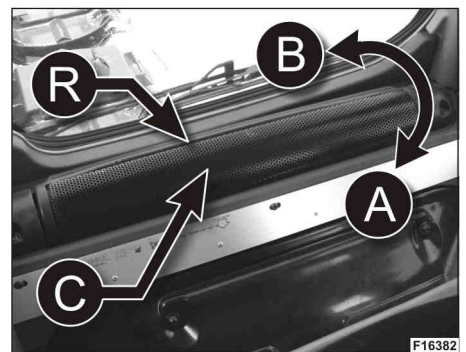
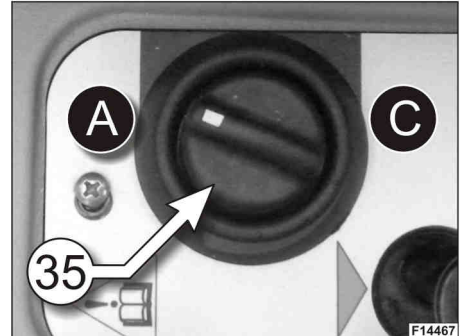
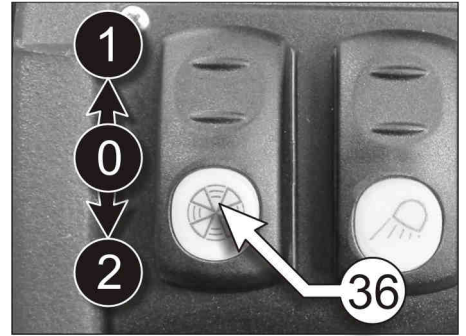

• ROOF-MOUNTED BEACON (33)

Push the switch (33) to operate the roof-mounted rotating beacon.

Refer to the rules for road use described in the "STICKERS WITH CONTROL DESCRIPTIONS - LEAFLETS IN THE CABIN" chapter, for instructions on the use of this beacon. Local and national regulations may also apply.

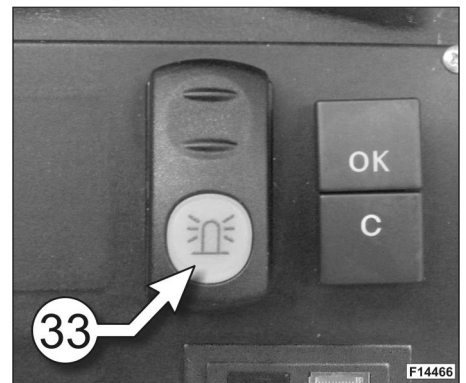

• INDICATOR LAMP SHOWING THAT BUTTON (U) ON THE JOYSTICK IS PRESSED (JOYSTICK ENABLE BUTTON)

Please refer to section "JOYSTICK ENABLING BUTTON (U)" in paragraph "TELESCOPIC BOOM CONTROL JOYSTICK (1)".

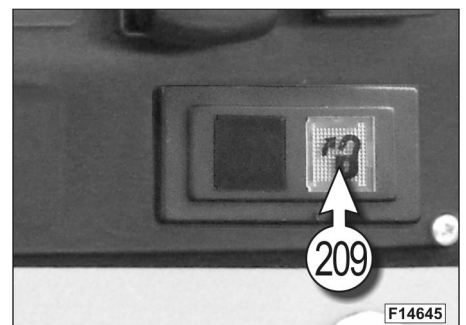

DYNAMIC LOAD CONTROL SYSTEM (M-CDC)



- INTRODUCTION

The dynamic load control system constantly monitors the longitudinal stability of your machine depending on the load being lifted on the carriage, on the position of the telescopic boom and on the attachment installed, so as to always ensure maximum operating safety.

The following paragraphs provide all necessary information for the correct operation of the dynamic load control system installed on your machine. Before operating your machine, please read the following very carefully.

- NOMENCLATURE OF DISPLAY (D)

When the instrument panel is switched on (ignition key (8) to the "R" position) (Fig. 1), the system displays a screen with the MERLO symbol (Fig. 2) for 3 seconds and then automatically shifts to the main screen.

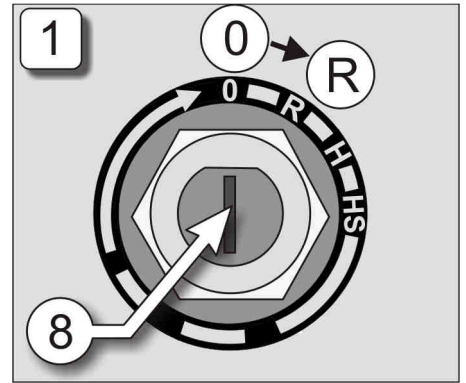



The main screen shows the following information:

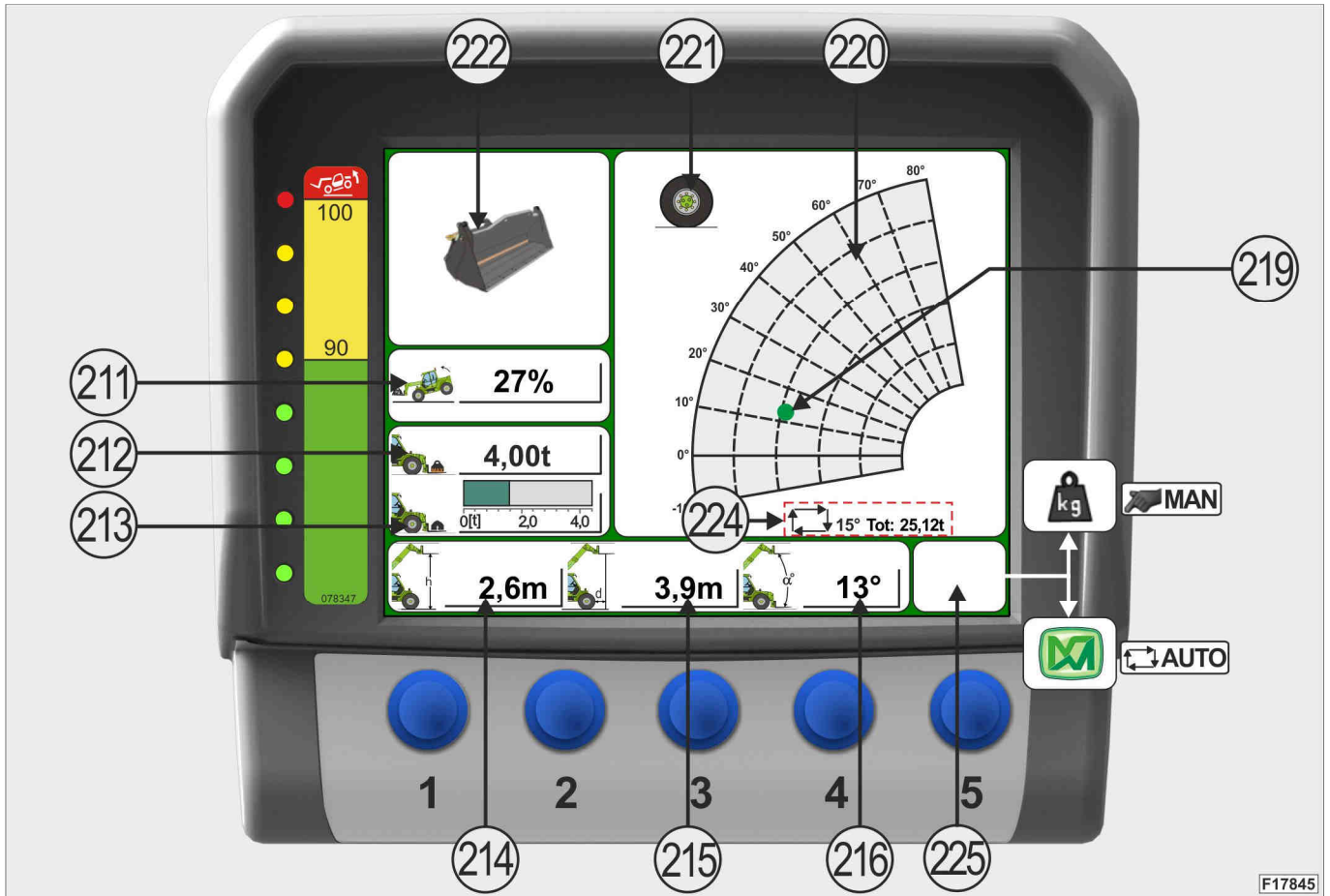

REF.	DESCRIPTION
211	Percentage longitudinal stability limit
212	Maximum liftable load in the spot where the telescopic boom is (this value depends on the attachment)
213	Bar graph indicating the load effectively lifted in relation to the equipment installed
214	Height of the load from the ground (expressed in metres)
215	Distance between the external limit of the tyres (or of stabilizers, if available) (expressed in metres)
216	Telescopic boom lift angle (expressed in degrees)
219	Coloured indicator (green, amber, red) showing the position of the load being lifted on the carriage
220	Dynamic load chart depending either on the attachment installed on the machine (automatic identification) or on the position of selector (204) (manual identification)
221	'Machine on tyres' indication
222	Image of the attachment installed on the machine and automatically identified by the system
224	Information on the weighing: operating mode, lift angle set by the operator, total weighing
225	In the MAN WEIGHING mode: manual weighing – In the AUTO WEIGHING mode: no command



• ACTIVATION OF THE GRAPHIC BAR FOR CONTROL SELECTION

Display (D) of the load control system is equipped with a floating bar which shows control buttons P1, P2, P3, P4 and P5. The activation of this floating bar depends on the weighing mode selected by the operator:

1) In the 'AUTO WEIGHING' mode (see paragraph 'WEIGHING SCREEN'), when one of the 5 selection buttons (P1, P2, P3, P4 or P5) is pressed, the system activates the graphic bar at the bottom of display (D) where the executable functions are shown. The operator has 5 seconds to press the button corresponding to the function to be executed. If no selection button is pressed within 5 seconds, the system deactivates the graphic bar.

2) In the 'MAN WEIGHING' mode (see paragraph 'WEIGHING SCREEN'), when one of the 4 selection buttons (P1, P2, P3 or P4) is pressed, the system activates the graphic bar at the bottom of display (D) where the executable functions are shown. The operator has 5 seconds to press the button corresponding to the function to be executed. If no selection button is pressed within 5 seconds, the system deactivates the graphic bar.

If button P5 is pressed in the manual mode, it does not activate the graphic bar but it starts a weighing procedure for the load being lifted (see paragraph 'MANUAL WEIGHING' (E)

The functions corresponding to the selection buttons are the following:

- (P1): press button (P1) to activate the setup menu for display (D), where you can adjust both display brightness in the daytime/night illumination mode and the volume of the loudspeaker.
- (P2): press button (P2) to switch on the video camera installed on the machine (available as an option). Each time button (P2) is pressed again, the system goes through all the video cameras available on the machine (check whether your machine is equipped with optional video cameras)
- (P3): this button does not activate any function on the machine
- (P4): press button (P3) to activate the daytime/night illumination mode for display (D)
- (P5): press button (P5) to activate the weighing screen (for further information please refer to the instructions provided in paragraph 'WEIGHING SCREEN').

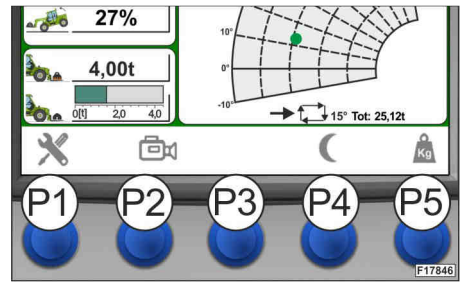

• DISPLAY SETUP (BUTTON P1)

Carry out the following operations to adjust the brightness of display (D) (both in a daytime and in a night mode) and the volume of the loudspeaker:

- activate the menu bar
- press button (P1): a screen appears where you can adjust both display brightness and volume
- press button (P2) to select the graphic bar corresponding to the setting you need to modify (in this order: daytime brightness (A), night brightness (B), volume (C))
- press buttons (P3) and (P4) to set the desired values for both brightness and volume (they can both be adjusted from a minimum of 0 to a maximum of 100)

Press button (P1) to exit the setup screen for display (D).

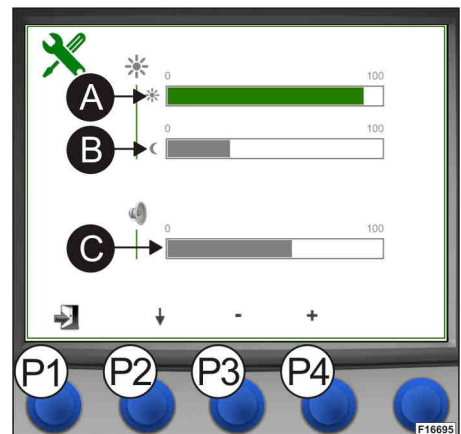

• SELECTION OF THE VIDEO CAMERA (BUTTON P2)

Carry out the following operations to view the images from the video cameras installed on your machine (available as options) on the screen of display (D) in the cab:

- activate the menu bar.
- press button (P2): the system displays CHANNEL 1. Press button (P2) again to change over to CHANNEL 2.
- press button (P1) to go back to the main screen.





• SELECTION OF THE DAYTIME/NIGHT MODE FOR DISPLAY ILLUMINATION (BUTTON P4)

Carry out the following operations to select either the daytime or the night mode for the illumination of display (D):

- activate the menu bar
- press button (P4) to change over from the daytime mode to the night mode for the illumination of display (D) and vice versa. The system informs the operator about the selected mode by displaying either window '1' (daytime mode) or '2' (night mode) in the middle of display (D).

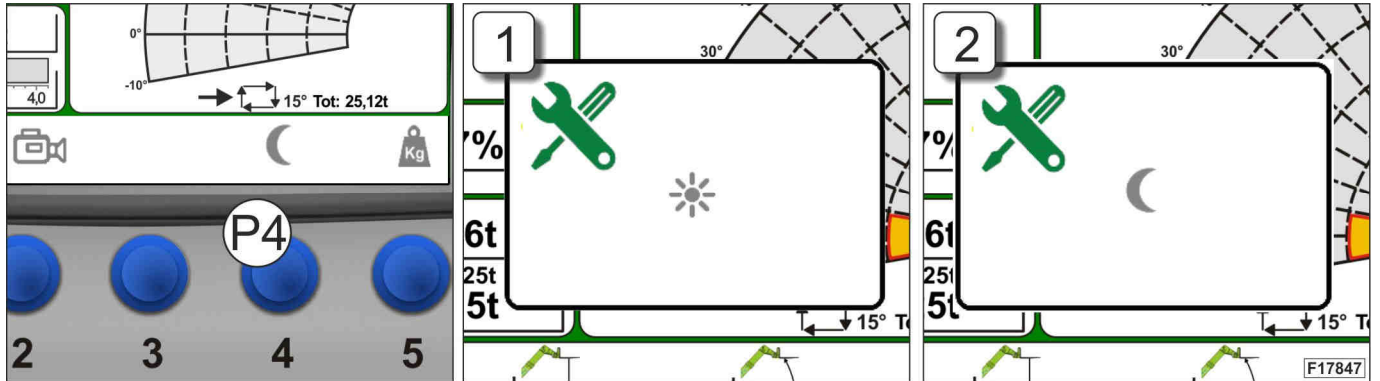

• WEIGHING SCREEN (BUTTON P5)

From the main screen, activate the menu bar, then press button (P5) to enter the weighing screen, where the following information is shown:





REF.	DESCRIPTION
A	Net weight lifted by the attachment installed on the carriage (expressed in tonnes)
B	Table showing the latest 20 weighings stored in the system, including the total weight
C	Deletion of all weighings stored in the system. The total is set back to zero.
D	Attachment tare
E	Manual weighing
F	Selection of the weighing mode: either automatic or manual
G	Modification of weighings stored in table 'B'
P1	Button for exiting the weighing screen and going back to the main screen
P2	Button for scrolling the weighing menu
P3	Button for confirming the item selected from the menu
P4	Button for decreasing the angle for automatic weighing
P5	Button for increasing the angle for automatic weighing

1) INSTRUCTIONS FOR WEIGHING A LOAD

In order for the weighing to be as accurate as possible, please check that the following conditions are met:

- 1) your machine should always be placed on a flat, compact surface
- 2) your machine should be standing still, with its wheels aligned with the chassis
- 3) the telescopic boom should be fully retracted and in a horizontal position
- 4) the carriage should be in a vertical position
- 5) the recommended weighing mode is the manual one (MANUAL WEIGHING)

In these conditions the approximate tolerance of the load readout should be about $\pm 5\%$ of the maximum rated load. The value of the load being lifted is to be considered a mere indication for the operator. It has no fiscal significance and it is not a certified weight value.

The following part of this paragraph describes the various functions of the weighing system.

2) RESET (C)

The reset control allows you to delete all the weighing values stored in table 'B'. When all the partial weighing values are deleted, the overall weighing value is set back to zero too.

To carry out the reset procedure you need to scroll the weighing screen with button (P2) until you select 'RESET'. Then press (P3) to confirm. The overall weighing value is also shown on the main screen in field (224). When the RESET command is executed, the value shown in field (224) is set back to zero too.

Press button (P1) to go back to the main screen.

3) TARE (D)

This control allows you to tare the weighing system. In this way field (A) will subsequently show only the weight of the load being lifted, without the weight of the attachment.

To carry out the taring procedure you need to scroll the weighing screen with button (P2) until you select 'TARE'. Then press (P3) to confirm. The value of the measured weight, expressed in tonnes, appears next to the 'TARE' inscription.

Press button (P1) to go back to the main screen.

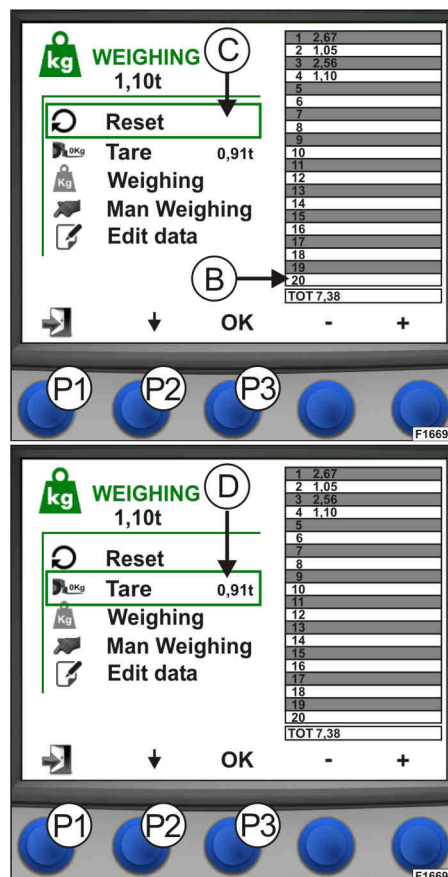



4) MANUAL WEIGHING (E)

Use this control to manually weigh the load being lifted on the attachment. The data measured by the system are shown in table 'B', from cell number 1 to cell number 20. After 20 weighings all the values scroll up, and the next values are displayed at the bottom of the table. The total at the bottom of table 'B' is always the sum of all weighings, including the ones which are not displayed.

To carry out the manual weighing procedure you need to scroll the weighing screen with button (P2) until you select 'WEIGHING'. Then press (P3) to confirm. A tone confirms that the weighing procedure was successfully completed, and the system stores the value in table 'B'.

To know the sum total of all weighings please refer to the figure next to the 'TOT' inscription, which is shown in the bottom row of the table; this total increases up to a maximum of 9999.99 t. (Fig. 1)

Press button (P1) to go back to the main screen.

You can also carry out a manual weighing procedure from the main screen by pressing button (P5); a tone confirms that the weighing procedure was successfully completed, and the system stores the value. On the main screen you can also see the total of the weighings, whose value is shown under the load chart in field (224). The manual weighing procedure can be carried out from the main screen only if you have previously selected the 'MAN WEIGHING' item on the weighing screen. (Fig. 2)

5) WEIGHING MODES (F)

Use this control to set the weighing mode:

- 1) MANUAL
- 2) AUTOMATIC

Is the manual mode selected, symbol 'X' appears with the 'MAN WEIGHING' inscription next to it. Is the automatic mode selected, the 'Y' symbol appears with the 'AUTO WEIGHING' inscription next to it. For the manual weighing procedure please refer to the instructions provided in the previous step (MANUAL WEIGHING 'E'), while for the automatic weighing please refer to the following instructions.

Scroll the weighing screen with button (P2) until you select 'AUTO WEIGHING', then press button (P3) to confirm. Now you can set a boom lift angle beyond which the system automatically carries out a weighing. Such angle should be set using buttons P4 (decrease) and P5 (increase), and should range between 0° and 70°. Once these functions are set you need to press button (P1) and to go back to the MAIN SCREEN, because the automatic weighing does not work in the WEIGHING SCREEN (Fig. 3).

To confirm that the system was correctly set in the automatic mode, field (224) on the main screen shows the 'Y' symbol and the value you selected for the boom lift angle (in degrees).

In this way, whenever the telescopic boom is lifted beyond the angle you selected, the system carries out an automatic weighing (emitting the corresponding tone), and stores the value in table 'B'. The sum total of the weighings is always shown on the main screen, under the load chart and next to the 'TOT' inscription (Fig. 4).

In order to have a new automatic weighing available you need to lower the telescopic boom until it is 5° below the value you set for the lift angle; if not, when you raise the telescopic boom again, the system will not carry out any automatic weighing.

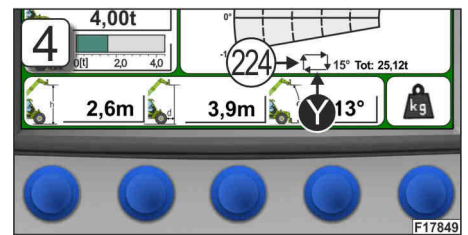
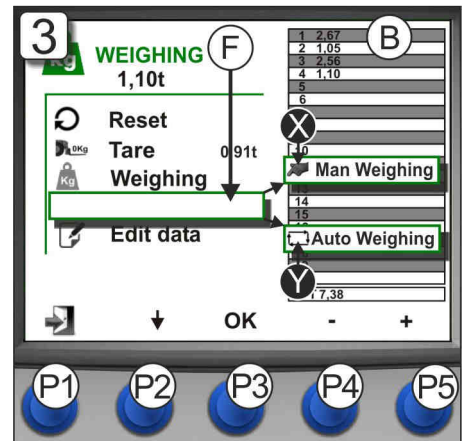
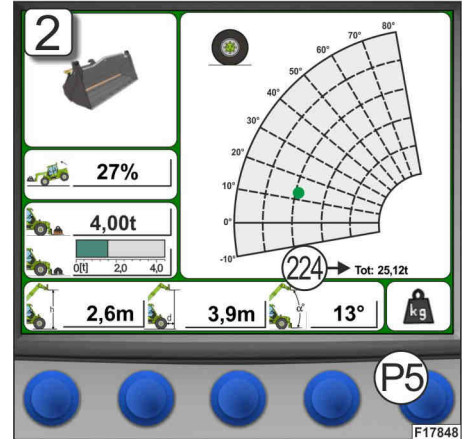
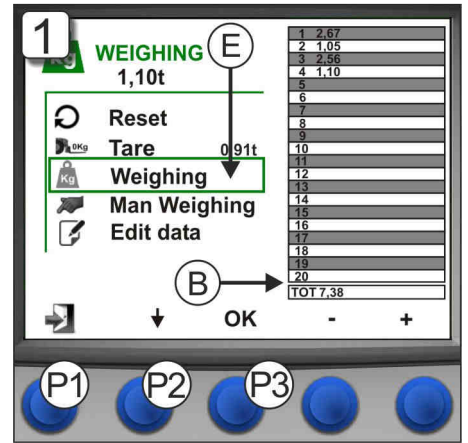



6) WEIGHING MODIFICATION (G)

Should you need to either modify or delete one or several weighings stored in table 'B' you can do that using the modification function available on the WEIGHING SCREEN. Scroll the weighing screen with button (P2) until you select 'EDIT DATA', then press button (P3) to confirm. Now the manual weighing symbol and an eraser appear under buttons (P4) and (P5) respectively.

To select the weighing to be modified press button (P2) until this is highlighted in a flashing mode, then press either button (P4) to repeat a manual weighing or button (P5) to delete the weighing (Fig. 5). Press button (P3) to confirm your selection.

Press button (P1) to go back to the main screen.

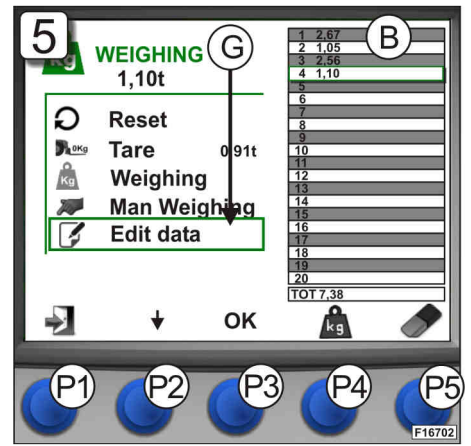

• SWITCH FOR THE SELECTION OF THE TYPE OF ATTACHMENT INSTALLED ON THE CARRIAGE

Your machine is equipped with a 4-position selector switch (204) which allows the operator to select -either manually or automatically- the type of attachment installed on the carriage, so as to determine the load capacity chart suitable for the machine/attachment combination.

The 4 positions of switch (204) for the selection of the type of attachment installed are the following (Fig. 1):

- a) AUTO: self-identification of the attachment installed on the carriage
- b) 0.5/0.6: attachments where the centre of gravity of the load being lifted is 0.5 / 0.6 metres away from the carriage
- c) 1.5: attachments where the centre of gravity of the load being lifted is 1.5 metres away from the carriage
- d) 4: attachments where the centre of gravity of the load being lifted is 4 metres away from the carriage

The graphic representation of selector (204) is also shown on display (D) in the cab, in field (222) (Fig. 2), and it is displayed when:

- no attachment is installed on the carriage.
- no attachment is identified on the carriage.
- an error/a failure occurs in the attachment self-identification system

When an attachment is installed and identified on the carriage and the system works correctly, the graphic representation of selector (204) in field (222) changes over to the symbol of the attachment installed (see below in this paragraph)

For the operation modes of selector (204) please refer to the following instructions:

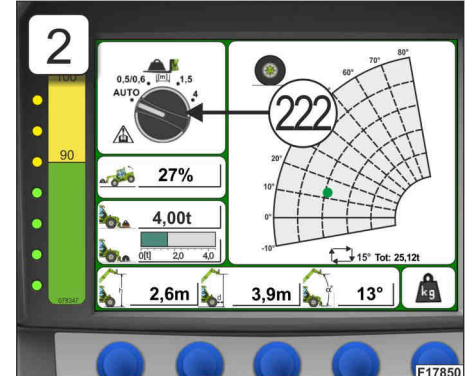
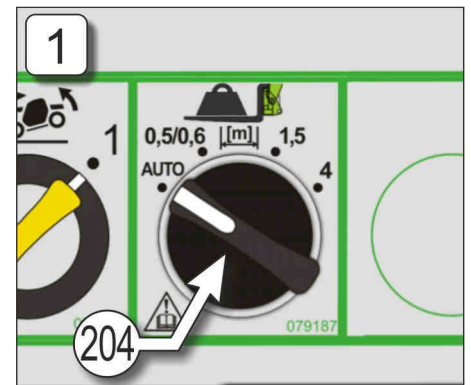



• SELF-IDENTIFICATION OF AN ATTACHMENT (selector (204) in the AUTO position)

When an attachment equipped with a self-identification sensor is installed on the carriage, you need to shift selector (204) to the "AUTO" position; in this case the system automatically determines the appropriate working chart for the machine/attachment combination, thus calculating the correct stability index, the maximum load capacity and the safe working area. Then the icon of the identified attachment (a bucket in this case) appears in field (222) (Fig. 3).

When an attachment equipped with a self-identification sensor is installed on the carriage but selector (204) is not shifted to the "AUTO" position, the following activates:

- red indicator of the LED graphic bar (210)
- red indicator (219) showing the position of the load on the dynamic load chart
- warning light (54) on instrument panel (C)
- audible alarm in the cab

In this case the system locks machine controls immediately and window "X" appears in the middle of display (D) prompting you to turn selector (204) to the "AUTO" position (Fig. 4).



WARNING!

The attachment self-identification system is disabled if operating mode selector (6) is in the "B" position (road travel). In this case you need to turn selector (6) to the "A" position (movements enabled).

If the self-identification system works correctly but there is no graphic representation of the attachment installed on the carriage, the machine signals it by showing the corresponding symbol in field (222) of display (D) in the cab (Fig. 5).

For a better comprehension of both the self-identification system and the manual selection of attachments a table is provided, listing all graphic representations shown in field (222) of display (D), together with their description.

• MANUAL SELECTION OF AN ATTACHMENT (selector (204) in the 0.5/0.6 or 1.5 or 4 position)

When either an attachment not equipped with a self-identification sensor is installed on the carriage or an error/malfunctioning occurs in the system, you need to manually select the category the attachment belongs to by operating selector (204) as follows (Fig. 6):

- turn selector (204) to the "A" position (0.5/0.6) when attachments are installed whose centre of gravity is between 0.5 and 0.6 metres ahead of the carriage
- turn selector (204) to the "B" position (1.5) when attachments are installed whose centre of gravity is within 1.5 metres ahead of the carriage
- turn selector (204) to the "C" position (4) when attachments are installed whose centre of gravity is within 4 metres ahead of the carriage

In this way the machine gets ready to be used with the selected attachment based on attachment category, determining the work chart and calculating the correct stability index, the maximum load capacity and the safe working area. Field (222) shows the graphic representation of the position of selector (204) (Fig. 7)

If the selector (204) is turned to the AUTO position and an attachment not equipped with a self-identification sensor is installed on the carriage, or an error/malfunctioning occurs in the system, the system automatically activates the work chart corresponding to the "C" position (centre of gravity of the load placed 4 metres ahead of the carriage).

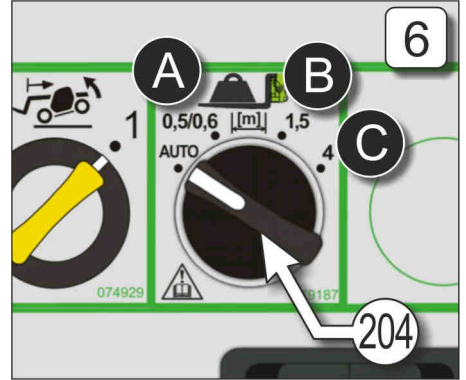
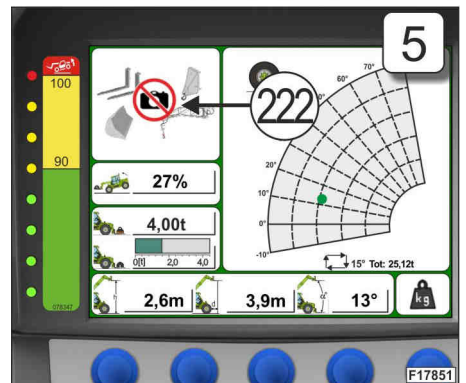
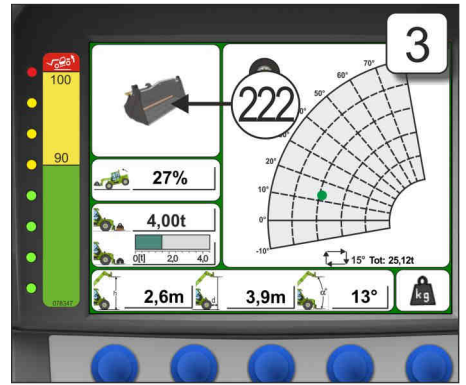











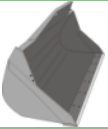

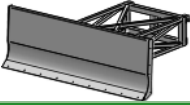
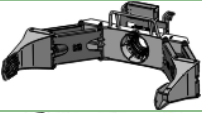

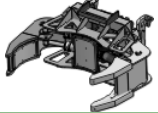
SYMBOL SHOWN IN FIELD (222)	DESCRIPTION
-----------------------------	-------------



	<p>The attachment installed on your machine was correctly identified by the system, but the corresponding image is not available in the database.</p> <p>Make sure that selector (204) is turned to the AUTO position</p>
	<p>The attachment installed on your machine is either not equipped with a self-identification sensor, or it was not automatically identified by the system due to a system failure or malfunctioning.</p> <p>Manual selection of the type of attachment installed with selector (204) was necessary. When selector (204) is in the AUTO position, mode "C" of the load chart is active, referring to attachments whose centre of gravity is 4 metres ahead of the carriage.</p>
	<p>The attachment installed on your machine is either not equipped with a self-identification sensor, or it was not automatically identified by the system due to a system failure or malfunctioning.</p> <p>Manual selection of the type of attachment installed with selector (204) was necessary. When selector (204) is in the 0.5/0.6 position, mode "A" of the load chart is active, referring to attachments whose centre of gravity is between 0.5 and 0.6 metres ahead of the carriage.</p>
	<p>The attachment installed on your machine is either not equipped with a self-identification sensor, or it was not automatically identified by the system due to a system failure or malfunctioning.</p> <p>Manual selection of the type of attachment installed with selector (204) was necessary. When selector (204) is in the 1.5 position, mode "B" of the load chart is active, referring to attachments whose centre of gravity is no more than 1.5 metres ahead of the carriage.</p>
	<p>The attachment installed on your machine is either not equipped with a self-identification sensor, or it was not automatically identified by the system due to a system failure or malfunctioning.</p> <p>Manual selection of the type of attachment installed with selector (204) was necessary. When selector (204) is in position 4, mode "C" of the load chart is active, referring to attachments whose centre of gravity is no more than 4 metres ahead of the carriage.</p>
<p>Attachments whose centre of load gravity is 0.5/0.6 metres from the machine carriage (position "A" of selector 204)</p>	
	<p>The TRAVELLING LIFT ON CARRIAGE - SIDE-SWINGING CARRIAGE / CARRIAGE WITH FLOATING FORKS - FEM CARRIAGE / EXTRA-LARGE FORK CARRIAGE attachment, installed on the machine, was correctly identified by the system.</p>
	<p>The BRICK HANDLER attachment installed on the machine was correctly identified by the system.</p>
	<p>The CHOPPER attachment installed on the machine was correctly identified by the system.</p>
	<p>The HAY BALE HANDLER WITH GRABS / 2/3 FOLDING-SPIKE FORK FOR HAY BALES / HAY BALE FORK WITH SLIDING PROTECTION attachment, installed on the machine, was correctly identified by the system.</p>
	<p>The MANURE FORK WITH GRABS attachment installed on the machine was correctly identified by the system.</p>
	<p>The CARRIAGE-MOUNTED HOOK attachment installed on the machine was correctly identified by the system.</p>
	<p>The 4 IN 1 BUCKET attachment installed on the machine was correctly identified by the system.</p>
	<p>The MULTI-PURPOSE BUCKET WITH GRABS attachment installed on the machine was correctly identified by the system.</p>
	<p>The DOUBLE LOG GRABS attachment installed on the machine was correctly identified by the system.</p>

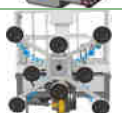

4 - CONTROLS AND INSTRUMENTS

	The LOOSE MATERIAL BUCKET / REHANDLING BUCKET / DIGGING BUCKET attachment, installed on the machine, was correctly identified by the system.
	The CARRIAGE-MOUNTED WINCH attachment installed on the machine was correctly identified by the system.
	The PUSHING BLADE attachment installed on the machine was correctly identified by the system.
Attachments whose centre of load gravity is 1.5 metres from the machine carriage (position "B" of selector 204)	
	The WHEEL MANIPULATOR attachment installed on the machine was correctly identified by the system.
	The CONCRETE MIXING BUCKET attachment installed on the machine was correctly identified by the system.
	The ROUND-BALE HANDLER attachment installed on the machine was correctly identified by the system.
	The FRONT CLAMPS attachment installed on the machine was correctly identified by the system.
	The REDUCED-HEIGHT CRANE ARM / TELESCOPIC CRANE ARM attachment, installed on the machine, was correctly identified by the system.
	The FLY JIB / FLY JIB WITH WINCH attachment, installed on the machine, was correctly identified by the system.
Attachments whose centre of load gravity is 4 metres from the machine carriage (position "C" of selector 204)	
	The MINI TOWER JIB attachment installed on the machine was correctly identified by the system.
	The TUNNEL RIB HANDLER attachment installed on the machine was correctly identified by the system.
Attachments that cannot be used with the dynamic load control system in the event of malfunctioning, faults or absence of the self-recognition sensor.	
	The SLEWING HOIST attachment installed on the machine was correctly identified by the system.
	The COUNTER-CARRIAGE MOUNTED HOIST attachment installed on the machine was correctly identified by the system.
	The FIXED PLATFORM / TRILATERAL PLATFORM / TRILATERAL EXTENSIBLE PLATFORM attachment, installed on the machine, was correctly identified by the system.
	The PANEL HANDLING PLATFORM attachment installed on the machine was correctly identified by the system.
	The SPACE 11 attachment installed on the machine was correctly identified by the system.



• FRONT OVERTURN PREVENTION SYSTEM

The front overturn prevention system steps in when the machine is close to its longitudinal stability limit, and locks all aggravating movements.

While handling a load, the system automatically detects and processes the position of the load being lifted on the carriage, as well as the percentage stability of your machine. These values are shown on display (D) in the cab in 3 different ways:

- graphic representation of the load being lifted (indicator (219): green - amber - red)
- LED graphic representation (210) (green - amber - red) of the stability conditions of the machine
- number percentage representation (211) of the longitudinal stability limit

Depending on the number value shown in field (211), 3 stability conditions are determined:

• value between 0% and 90% (Fig. 1)

- machine is stable; no movement lockout
- indicator (219) is green-coloured
- graphic bar (210) has green LEDs on

• value between 90% and 100% (Fig. 2)

- the machine is close to its longitudinal stability limit; no movement lockout
- load chart indicator (219) is amber-coloured
- graphic bar (210) has amber LEDs on
- activation of intermittent audible warning signal in the cab. The frequency of the signal increases as the load gets closer to 100% (red zone)

• value beyond 100% (Fig. 3)

- the machine has reached its longitudinal stability limit, and all aggravating movements are locked as a consequence
- warning light (54) on the dashboard is on
- load chart indicator (219) is red-coloured
- graphic bar (210) has a red LED on
- activation of continuous audible warning signal in the cab

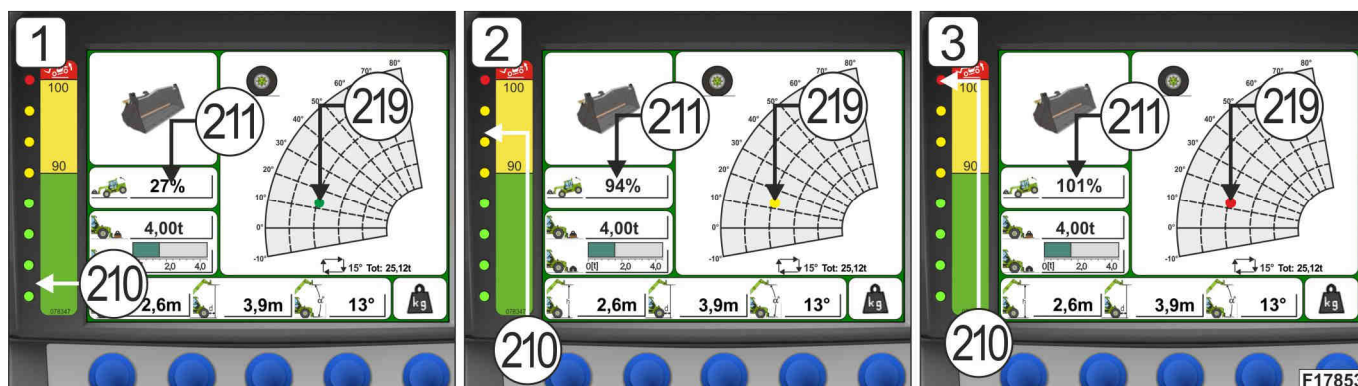

To restore safe operating conditions (both indicator (219) and LED graphic bar (210)), first retract the telescopic boom.

If either it's not possible to retract the telescopic boom or this manoeuvre is not sufficient to restore safe operating conditions for your machine, turn operating mode selector (6) to the "C" position and hold it in that position. Then proceed slowly and very cautiously with non-aggravating manoeuvres until safe operating conditions are restored (both warning light 54 and audible alarm in the cab are off; both indicator (219) and graphic bar (210) are green-coloured).



WARNING!

Before starting any operation, when the telescopic boom is still close to the ground, take your machine to its overturn limit to check that the overturn prevention system and the corresponding indicators work correctly. Should you find any malfunctioning, do not use your machine until the fault is repaired.

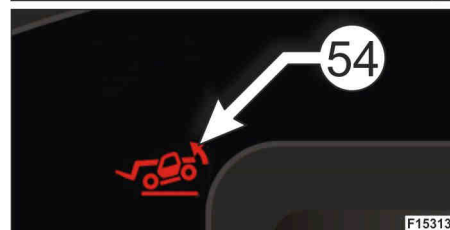
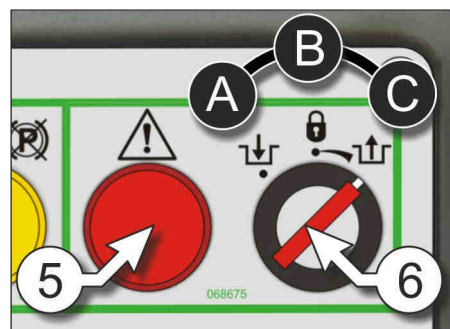

**TELESCOPIC BOOM CONTROL JOYSTICK AND SELECTION OF THE DRIVE DIRECTION (1)**

Your machine is equipped with a single-lever joystick (1) that allows you to control the 4 main movements of the telescopic boom, to select the drive direction (forward/reverse) of the machine and activate the second equipment hydraulic function. The controls provided on the joystick are:

- RAISING / LOWERING OF THE TELESCOPIC BOOM
(move the joystick forwards or backwards)

A = raising of the telescopic boom
B = lowering of the telescopic boom

- UPWARD / DOWNWARD ROTATION OF THE FORKS
(move the joystick to the left or right)

C = downward tilt of the forks
D = upward tilt of the forks

- EXTENSION / RETRACTION OF THE TELESCOPIC BOOM
(use thumb wheel R1)

1 = extension of the telescopic boom
2 = retraction of the telescopic boom

- OPERATION OF ATTACHMENTS FITTED ON THE CARRIAGE (AUX 1)
(use thumb wheel R2)

3 = uncoupling/control of attachment
4 = control of attachment

- OPERATION OF ATTACHMENTS FITTED ON THE CARRIAGE (AUX 2)
(use thumb wheel R3)

5 = control of attachment
6 = control of attachment

- SELECTION OF FORWARD / REVERSE DRIVE
(use buttons F, R, N)

- TELESCOPIC BOOM CONTROLS

The speed at which the movement is performed is proportional to:

- the tilt angle of the joystick (the further the joystick is moved, the faster the movement)
- the rotation of thumb wheels "R1", and "R2" (the further the wheel is rotated, the faster the movement)
- the rotation speed of the diesel engine (the higher the engine rpm, the faster the movement).

The movement stops automatically when the joystick or the respective thumb wheel is released. The possibility of combining the movements depends on the load conditions.

- SELECTION OF THE DRIVE DIRECTION (FORWARD / NEUTRAL / REVERSE)

The joystick (1) mounts buttons for selection of the drive direction (forward / neutral /reverse).

- Button F: forward drive selection

When forward drive is selected, the indicator light (LF) located next to the steering column is steadily illuminated.

- Button N: neutral selection

When neutral is selected, both indicator lights (LF and LR) are extinguished. The machine does not move when the accelerator is pressed.

- Button R: reverse drive selection

When reverse drive is selected, the indicator light (LR) located next to the steering column is steadily illuminated.

The (F,N,R) buttons on the joystick have the same identical functions as the (F,N,R) buttons located on the forward/reverse drive selector next to the steering column and both may be used (for example, you can select forward drive by pressing the "F" button on the joystick and subsequently press the "N" button on the forward/reverse drive selector (20) to select neutral, and so on...).

For further information on the safe operation of this control, please refer to the instructions in the paragraph "FORWARD/REVERSE DRIVE SELECTOR (20)" in this chapter.

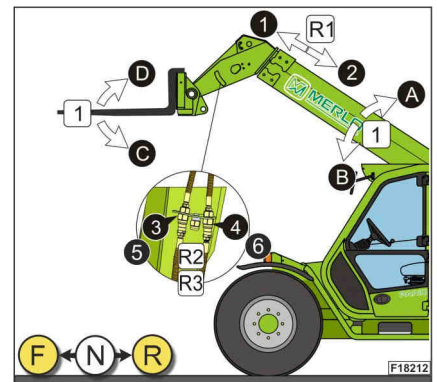
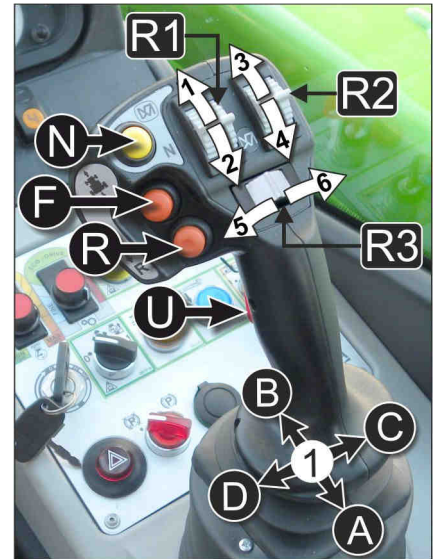



CAUTION! It is only possible to change the drive direction when the machine is travelling in first gear (slow travel). Do not change the drive direction when the machine is in second gear (fast travel).

When reverse drive is selected, the reverse alarm system will be activated automatically and an intermittent audible warning signal will sound.



WARNING! Before operating the machine, please mark off the area where the machine needs to be operated, in order to keep both people and vehicles away from it.

Should you need to operate the machine near overhead lines, the person in charge of safety shall inquire the minimum safety distance from such lines from the manager of said lines, as well as from the authorities in charge of safety and health in the workplace; in this way all necessary precautions shall be taken and potential accidents shall be prevented.

For further information please refer to paragraph "INSTRUCTIONS FOR A CORRECT USE OF THE MACHINE NEAR OVERHEAD LINES" in chapter "OPERATING INSTRUCTIONS".

HYDRAULIC OR HYDROSTATIC SYSTEM PRESSURE GAUGE (12)



WARNING! During normal operating conditions of the machine, the instrument must be left disconnected.

In case of loss of pressure in the hydraulic system, please refer to the instructions in the paragraph "HYDRAULIC SYSTEM OIL PRESSURE" in the chapter "SECURITY PERIODICAL INSPECTIONS".

In case of anomalies in the hydrostatic transmission system, please refer directly to the Merlo Service Centre for further information.

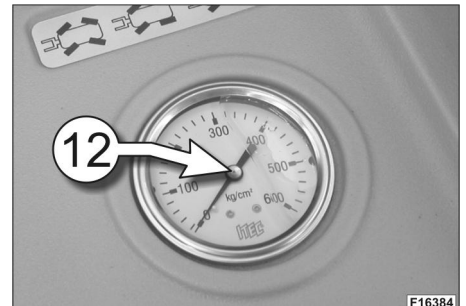

PEDALS (14-15)

ACCELERATOR PEDAL (14)

Operate the pedal to increase or decrease the diesel engine rpm.

BRAKE PEDAL (15)

Acting on the pedal you operate the disc brakes assembled on both vehicle axles. Thanks to the braking efficiency of the hydrostatic transmission service brakes are seldom used. We suggest to use from time to time services brakes to keep them efficient and to avoid pads sticking

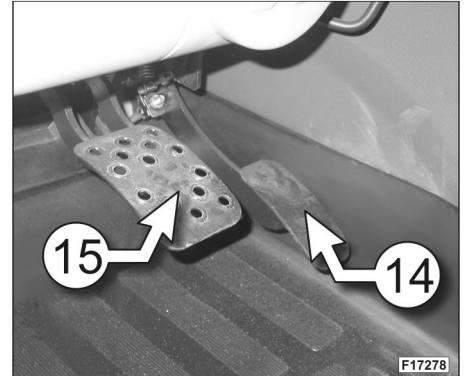

LEVER FOR THE ADJUSTMENT OF THE STEERING WHEEL (17)

Turn the steering wheel locking lever (17) to position B. Pull the steering wheel to the required position and lock by returning the locking lever to position A.



WARNING !
Never adjust the steering wheel angle whilst the machine is in motion.

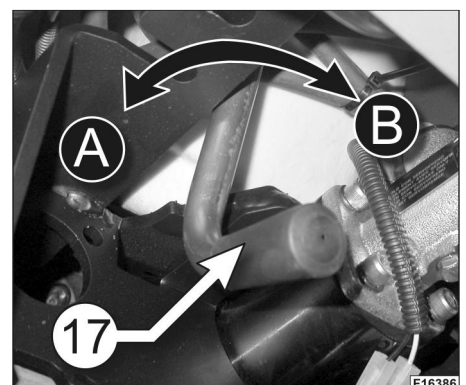



FORWARD / REVERSE DRIVE SELECTOR (20)

The drive direction (forward/reverse) of the machine can be selected in two ways:

- 1) by pressing the buttons (F,N,R) located on the joystick (1) (see paragraph "TELESCOPIC BOOM AND DRIVE DIRECTION CONTROL JOYSTICK" in this chapter)
- 2) by pressing the buttons (F,N,R) on the drive selector (20) located next to the steering column

The (F,N,R) buttons located on the forward/reverse drive selector have the same identical functions as the (F,N,R) buttons on the joystick (1) and both may be used to select the drive direction (for example, you can select forward drive by pressing the "F" button on the joystick (1) and subsequently press the "N" button on the forward reverse drive selector (20) to select neutral, and so on...).

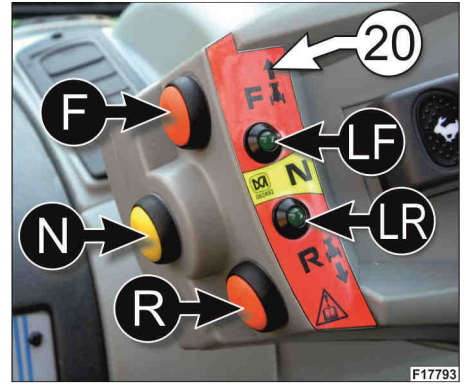

The operation of the (F,N,R) buttons located on the forward/reverse drive selector (20) next to the steering column is as follows:

- Button F: forward drive selection
When forward drive is selected, the indicator light (LF) located next to the steering column is steadily illuminated.
- Button N: neutral selection
When neutral is selected, both indicator lights (LF and LR) are extinguished. The machine does not move when the accelerator is pressed.
- Button R: reverse drive selection
When reverse drive is selected, the indicator light (LR) located next to the steering column is steadily illuminated.



CAUTION! *It is only possible to change the drive direction when the machine is travelling in first gear (slow travel). Do not change the drive direction when the machine is in second gear (fast travel). When reverse drive is selected, the reverse alarm system will be activated automatically and an intermittent audible warning signal will sound.*

ANGLE INDICATOR ON THE TELESCOPIC BOOM

Indicator "A" measures the telescopic boom vertical inclination. This value is useful to find the position of the transported load on the related load chart.

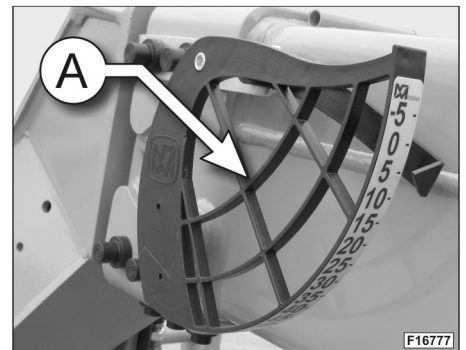



LIGHTS AND HORN ON/OFF LEVER (24)

Lever (24), placed beside the steering wheel, allows you to switch on/off the lights on your machine, and to operate the horn. To do so, engine start key (8) needs to be in position "R". Should engine start key (8) be in position "0", the operation of lever (24) is disabled.

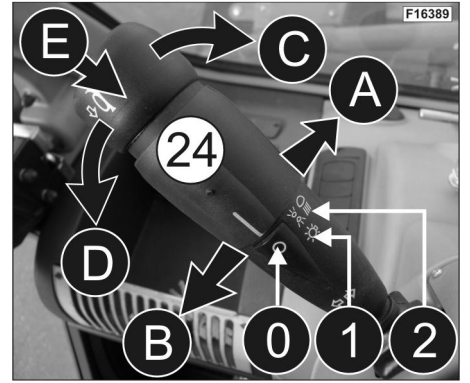

SWITCHING OFF THE LIGHTS (Fig.M)

To switch off all the lights on your machine, turn the switch of control lever (24) to position "0"

TAIL LIGHTS (Fig.N)

To switch on the tail lights, turn the switch of control lever (24) to position "1"

LOW-BEAM HEADLIGHTS (Fig.P)

To switch on the low-beam lights, turn the switch of control lever (24) to position "2"

TURN INDICATORS (Fig.R)

To switch on the right turn indicators, shift lever (24) to position "C"
To switch on the left turn indicators, shift lever (24) to position "D"

HIGH-BEAM HEADLIGHTS (Fig.S)

To switch on the high-beam lights, shift lever (24) to position "A"
To flash the high-beam lights, shift lever (24) to position "B"

HORN (Fig.T)

To operate the horn, press button "B" placed at one end of lever (24)

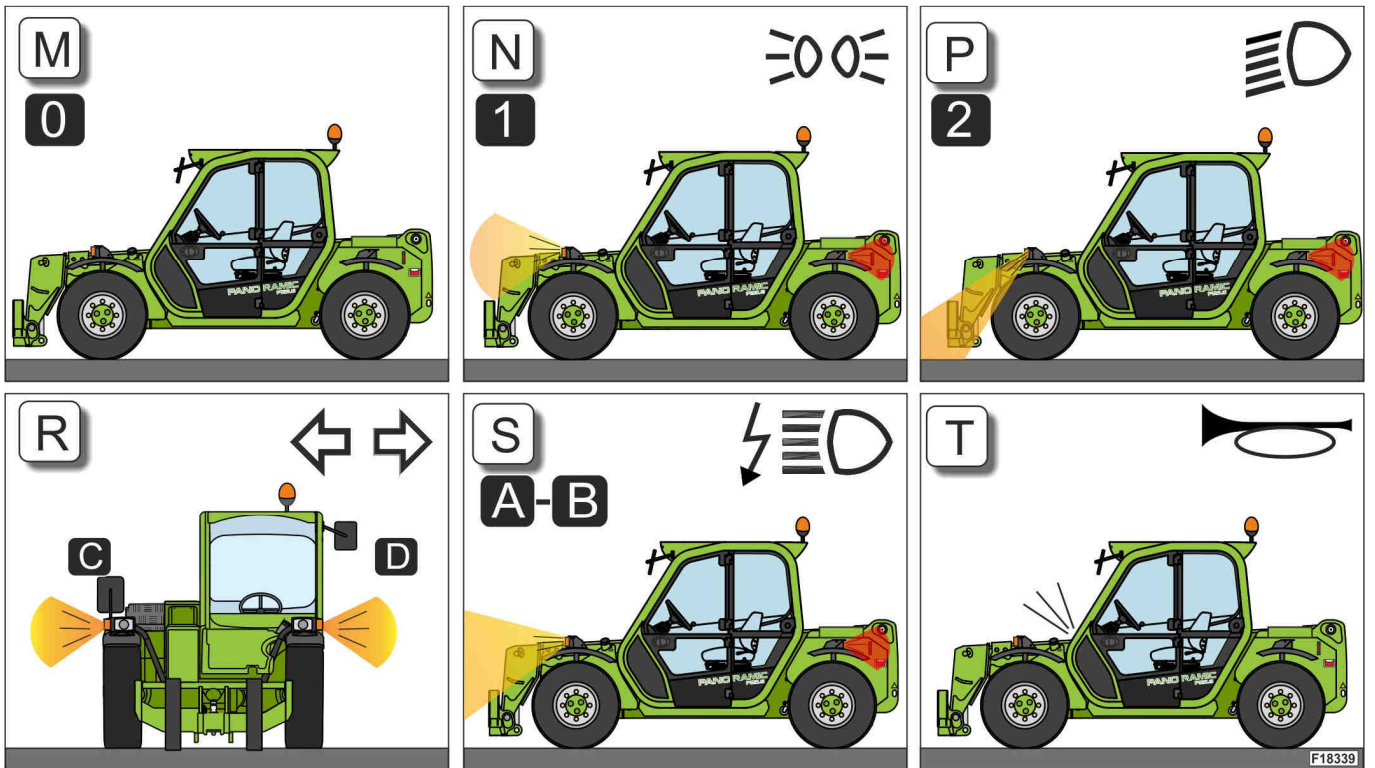

**STEERING MODE (29)**

The machine is fitted with a system which allows the operator to select one of three steering modes:

A) Steering with corrected turn angle

Use this mode to obtain a narrower steering angle.

B) Front axle steering

Use this mode when executing transfers on public roads.

C) Crab steering

Use this mode to move the machine laterally without losing the longitudinal alignment.

The desired steering mode must be selected while the machine is standing still, with all wheels aligned to the chassis. In order to correct a misalignment between the front wheels and the rear wheels, bring the steering wheel to its end stop on one side for a few seconds, then repeat on the other side.

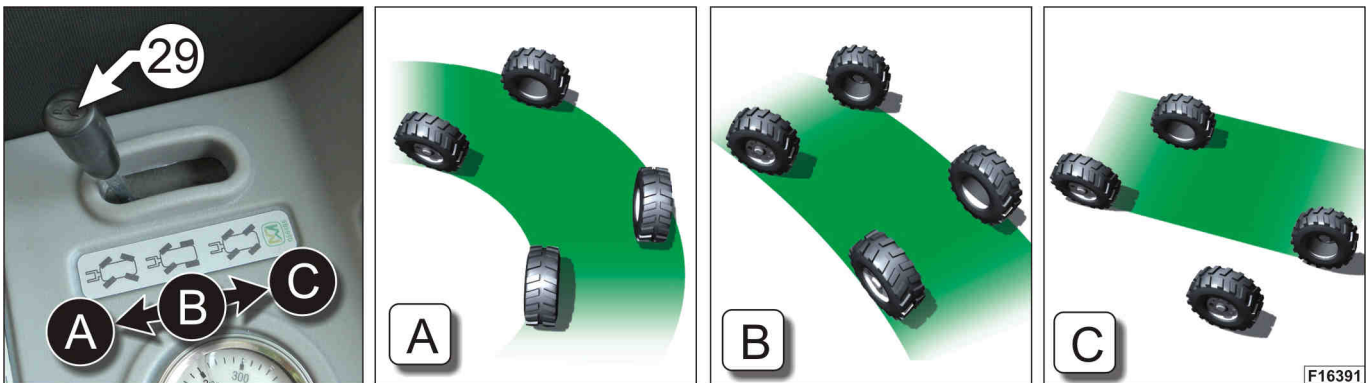

WARNING! Such correction can only be carried out when in "corrected turn angle" or "crab" mode, even if the misalignment occurred while using the front axle steering mode.

WINDSCREEN WIPERS AND WINDSHIELD WASHER (34), (7)

FRONT WINDSCREEN WIPER & WASHER SWITCH (34)

Two-positions switch: the first tripping operates the front windscreen wiper, the second operates the front and the rear windshield washer.

REAR WINDSCREEN WIPER (7)

Press button (7) to engage the rear windscreen wiper.

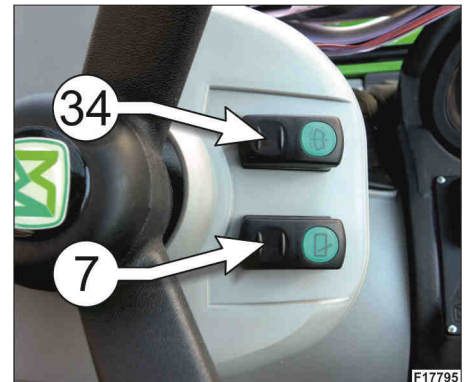
**HAND ACCELERATOR (86)**

This lever (86) permits the manual regulation of the diesel engine rpm.

By operating the pedal it is however always possible to reach the maximum rpm; on pedal release the engine returns to the set rpm.



WARNING!
The use of this control is prohibited when driving on the road.

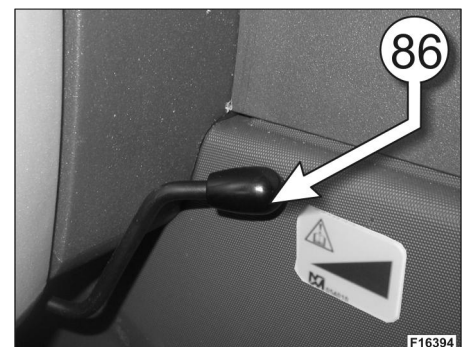



LATERAL AND LONGITUDINAL SLOPE INDICATORS

2 slope indicators are available on your machine:

- lateral slope indicator (A) is available on the windscreen
- longitudinal slope indicator (B) is available on the right window

Each indicator is provided with 2 scales:

- main scale 'X' (ranging from -35° to $+35^{\circ}$), with a 5° resolution
- precision scale 'Y' (ranging from -5° to $+5^{\circ}$) with a 1° resolution

For further information on slope indicators please refer to paragraph 'SLOPES', in chapter 'OPERATING INSTRUCTIONS'.

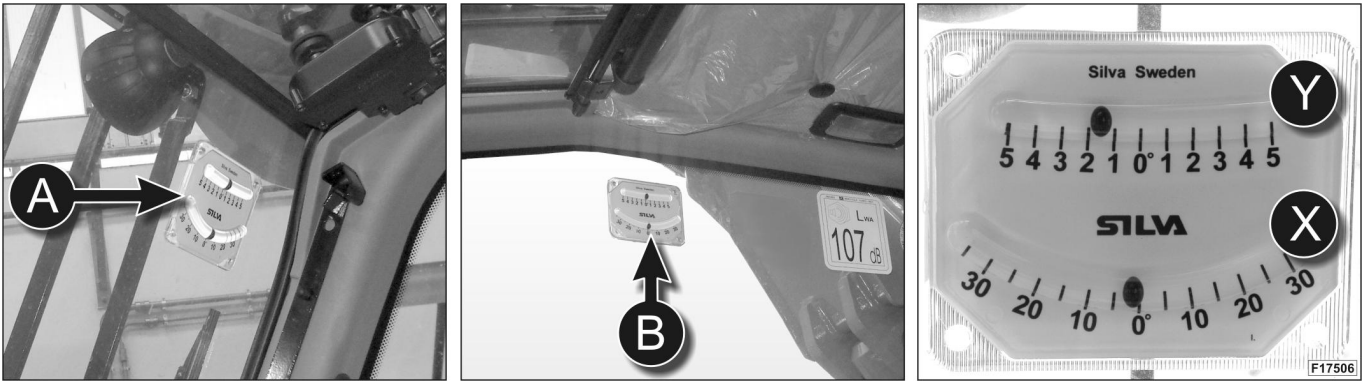

END OF CHAPTER



INDEX

INTRODUCTION 2

GENERAL INFORMATION 2

RULES FOR LOAD TRANSPORT 2

MACHINE OPERATING AREA 2

HOW TO HANDLE A LOAD 3

INSTRUCTIONS FOR STARTING YOUR MACHINE 5

INSTRUCTIONS FOR DRIVING YOUR MACHINE ON THE ROAD 10

INSTRUCTIONS FOR A CORRECT MACHINE USE IN THE VICINITY OF ELECTRICITY POWER SUPPLY LINES 13

USE OF THE MACHINE DEPENDING ON WIND STRENGTHS 13

VISIBILITY 14

EXTERNAL LONGITUDINAL STABILITY INDICATORS 17

PICK AND CARRY 17

END OF CHAPTER 17



INTRODUCTION

This chapter provides the instructions for using your machine as a variable reach fork lift truck. Please follow the instructions below very carefully, so as to ensure efficiency and utmost safety while working.



WARNING! Before starting to manoeuvre loads with the MERLO lift truck with variable forward reach, all information and safety instructions in this paragraph need to have been read and understood.

GENERAL INFORMATION

- when manoeuvring the loads never exceed the limits set in the load chart
- do not use counter-weights to alter the limits of the load chart
- never distance yourself from the machine while the engine is running or when there is a suspended load
- transporting people on the machine is absolutely forbidden if no platform, homologated and approved by Merlo S.p.A., is installed
- carrying a second operator on-board the machine is absolutely prohibited.

RULES FOR LOAD TRANSPORT

- always handle loads slowly and with caution
- if you are not transporting any loads, you are allowed to drive your machine from one spot to another with the boom raised to a maximum height of 2 metres (6 ft) from the ground
- if you are transporting a load, the boom must be in a transport position (see also paragraph "BOOM POSITION FOR ROAD TRAVEL"), and the forks must be lifted to about 0.5 metres (20 in) from the ground
- while driving your machine from one spot to another, avoid sharp acceleration and braking
- while driving your machine from one spot to another, always keep a low speed, and take all possible safety measures to prevent the load being transported from shifting on or falling from your machine

MACHINE OPERATING AREA

- check soil condition and make sure that the working area is well lit
- make sure that nobody is standing in the machine operating area
- make sure that there are no overhead lines in the machine operating area
- make sure that the machine operating area is always sufficiently lit; should the standard lighting system your machine is equipped with not be sufficient for the workplace, please contact either Merlo S.p.A. or your local dealer for additional solutions which may suit your needs.
- make sure that all the windows and the rear-view mirrors of your machine are always perfectly clean; clean them at regular intervals, so as to ensure good visibility over the machine operating area.

ATTACHMENTS AND ACCESSORIES

- only use accessories approved by Merlo S.p.A.
- check that the accessories of your machine are undamaged and work correctly
- check that the stability control system of your machine works correctly
- check that the accessories are correctly mounted on the tool-holder carriage
- always follow the load chart of the accessory being used
- never lift any load with only one fork
- never use ropes, chains or slings hitched to the forks, to the carriage or to the telescopic boom to lift any load. Always use the attachments designed for this purpose, which are type-approved and guaranteed by Merlo S.p.A.



HOW TO HANDLE A LOAD

This paragraph describes all the operations required to correctly handle a load with standard forks.

• CENTRE OF GRAVITY OF A LOAD

Before lifting a load, its weight and centre of gravity need to be found out. Remember that the centre of gravity of a load on the forks is calculated at 600mm from the heel of the fork. (Fig.1)

If irregular loads are manoeuvred, the centre of gravity needs to be calculated transversely before each manoeuvre (Fig.2).



WARNING! Manoeuvring a load that exceeds the maximum indicated in the machine's load chart is forbidden.

• MANOEUVRING A LOAD AT GROUND LEVEL

- make sure the ground where the load is to be placed is flat and firm
- position the machine near the load to be lifted with the telescopic boom completely retracted and the forks in a horizontal position (Fig.4)
- bring the gear direction switch (20) to position "N"
- level the machine perfectly flat using the side-tilt corrector (if the machine has one)
- regulate the width and centring of the forks in relation to the load to be lifted (Fig.5)
- extend the boom, bring the forks under the load and lift it a few centimetres (Fig.6)
- rotate the carriage a few degrees upwards and completely retract the telescopic boom (Fig.7)

• MANOEUVRING A CIRCULAR-SHAPED LOAD

For handling circular shaped loads (barrels, cans etc.) installation of the appropriate attachment, provided and homologated by Merlo S.p.a., on the machine carriage is necessary. In order to find out the attachment best suited to the type of circular load to be handled, contact the nearest dealer.

• MANOEUVRING A HIGH LOAD



WARNING! Before collecting a high load or before placing a load high up, correct levelling of the machine needs to be carried out checking, with particular attention, that the air bubble is in the central zone of the level. Never pick up or lay down any loads from above if your machine is not levelled correctly. Never exceed the limits set in the load chart.

- check that the place where the load is to be positioned is flat and strong enough to support the load
- check that the place where the load is to be positioned is within the operating area of the machine and respects the load chart
- check that the surrounding ground is flat and resistant in order to support the machine and the load to be handled
- move as near as possible to the area where the load is to be deposited
- prior to start any movement, set both speed range and forward/reverse selectors in their neutral position "N".

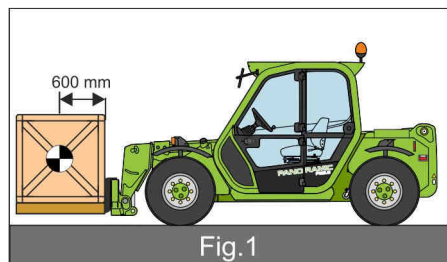

Fig.1

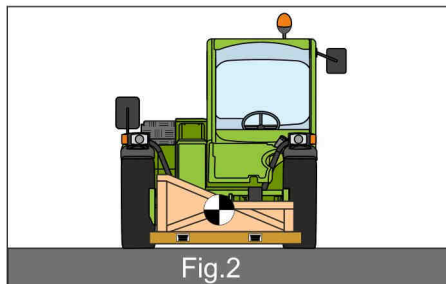

Fig.2

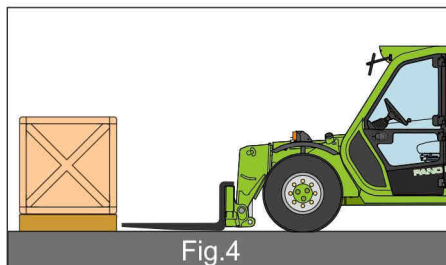

Fig.4

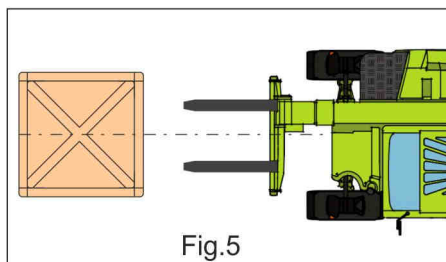

Fig.5

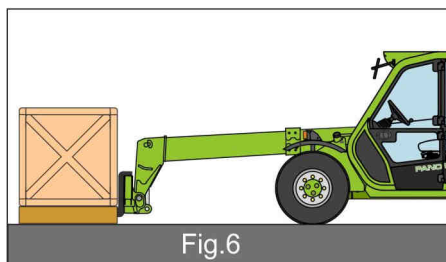

Fig.6

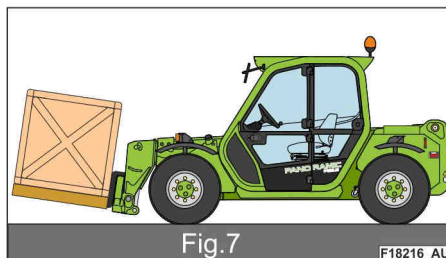

Fig.7

F18216_AU

**WARNING!**

Manoeuvring loads suspended on cables, chains, slings or other is prohibited if the machine is not equipped with the Merlo attachment specific to such a use (hook on forks, hook on carriage, crane boom, fly jib etc...)

When using compatible and homologated Merlo attachments always refer to the relevant load chart present in the holder provided in the cab.

If operations with the platform must be carried out near overhead electricity cables, the person in charge must ask whoever manages the cables and the area's health and safety authorities for the minimum safety distance from the cables, so that all necessary precautions for avoiding accident risks can be taken.

- bring the forks into a horizontal position and approach the load with care, lifting and extending the telescopic boom the minimum possible or, if necessary, slowly advancing the machine (Fig.8)
- position the forks under the load taking care that they insert easily (Fig.9)
- shift the direction control (20) into position "N"
- lift the load a few centimeters and tilt the carriage upwards (Fig.10)
- if possible, slowly and carefully reverse the machine then lower and retract the telescopic boom to bring the load into the transportation position (Fig.11)
- bring the machine, in the transport position, into the area where the load is to be placed
- lift and extend the telescopic boom until the load is above the stack; if necessary advance the machine with care. (Fig.12)
- shift the direction control (20) into position "N"
- bring the forks into a horizontal position and correctly place the load on top of the stack, lowering and retracting the telescopic boom (Fig.13). Reverse the machine in order to retract the forks

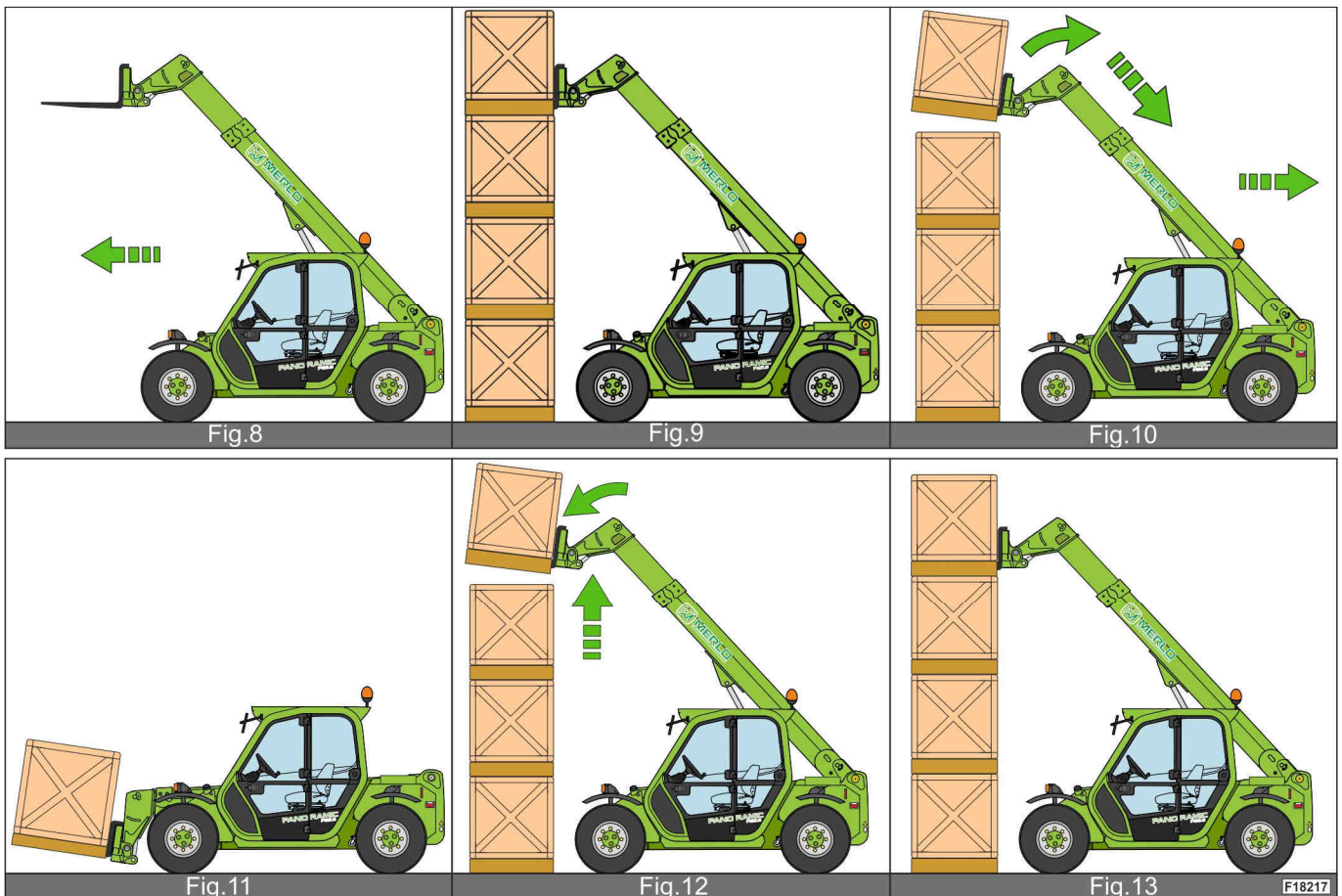



INSTRUCTIONS FOR STARTING YOUR MACHINE



WARNING!

Before starting to drive your MERLO machine all the information and safety instructions in this paragraph need to have been read and understood.

It is particularly important to have a good knowledge of the positioning and functioning of all the controls.

• GENERAL CONDITIONS

- always wear clothing suitable for driving a lift truck
- always remember to close the engine bonnet and other compartments
- adjust the seat to your own requirements in order to ensure safe and comfortable driving
- never drive with dirty, damp or oily hands or shoes
- always close the lower part of the cab door
- always wear the seatbelt and adjust it as described in the relevant paragraph in the chapter "CABIN"
- before every journey check correct functioning of the parking brake and the horn
- for driving on public roads front axle steering is necessary, shift the function mode switch(6) into a central position and switch on the flashing light on top of the cab
- never transport passengers in the cab and in no other part of the vehicle
- always respect the rules in force in the country where you are driving
- never extend parts of your body out of the cab window; always maintain a correct driving position
- manoeuvring the machine without a load must be done with the telescopic boom at a maximum of 2 metres (6 ft) above the ground
- manoeuvring the machine with a load on the forks must be done with the telescopic boom at a maximum of 0,5 metres (20 in) above the ground
- always look ahead of the machine and use the wing mirrors and rear view mirror constantly to see the road
- always drive with extreme care and in particular control your speed on wet, uneven or slippery ground
- avoid sudden braking
- the gear change forward/reverse must always be done with the vehicle stationary
- do not leave the vehicle with the engine running
- at night, light the working area use all the machine's headlights including the work lights (if present)
- be sure to have understood all of the machine's controls before starting to drive
- always carry out, at the beginning of each working day, the checks described in the following paragraphs



• GENERAL CHECKS BEFORE STARTING THE ENGINE

Carry out the following checks every day (before using the vehicle):

- keep all machine parts in due order and clean.
- inspect the exterior of the machine at the end to check that no screws or bolts are loose or missing and that there are no leakages of hydraulic oil
- roof rotating flashing beacon (figure 1)
- water level in the radiator (figure 2)
- hydrostatic transmission oil level (figure 3)
- tyre pressure and condition (figure 4)
- presence, function and good condition of the safety belt (figure 5)
- regulate the seat to ensure that all the driver controls can be conveniently reached.
- regulate the rear view mirrors to ensure good visibility from the driver's seat.
- check the correct opening and closure of the upper part of the driver's cab door.

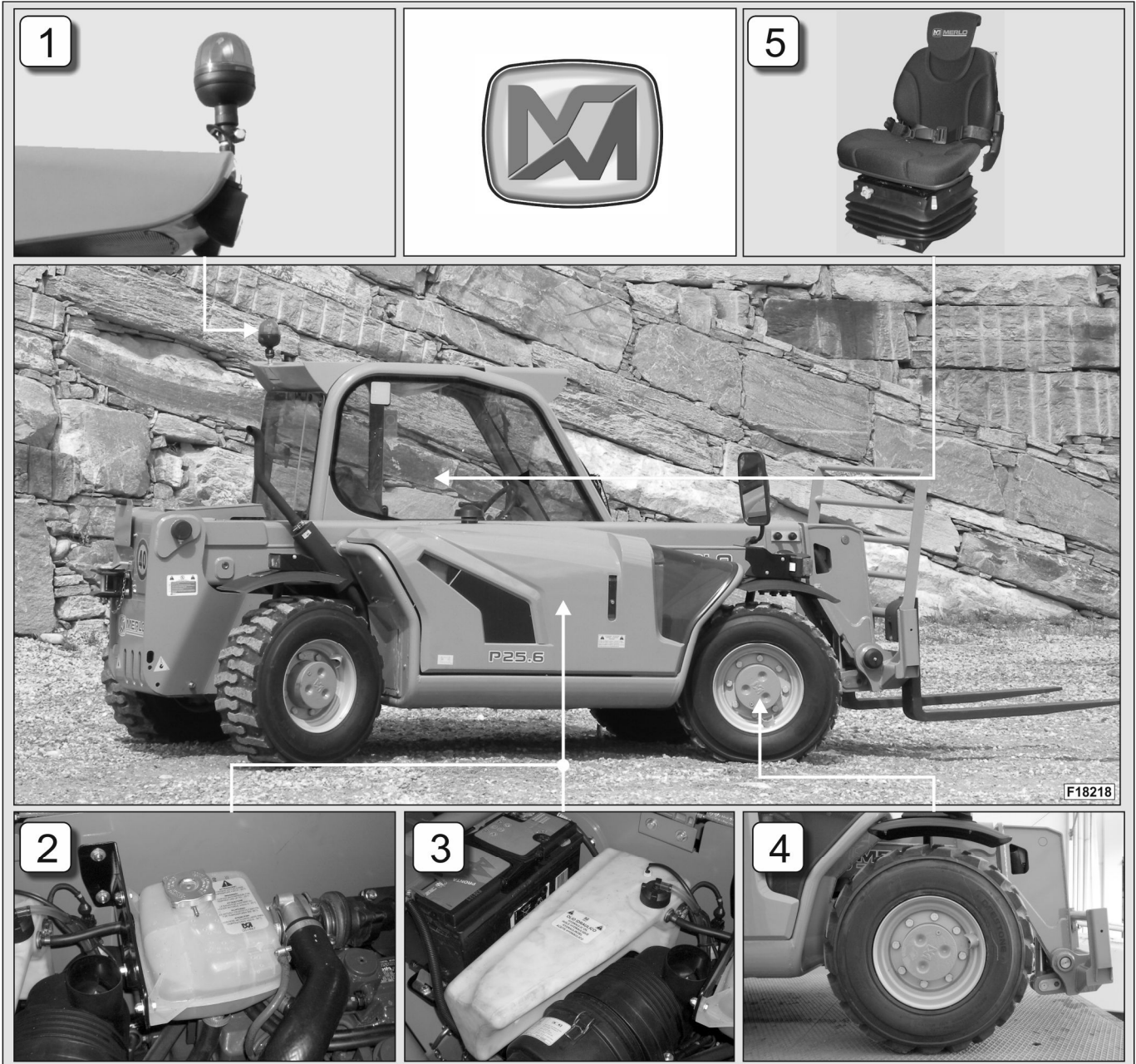



• CHECKS WITH THE IGNITION KEY (8) IN POSITION "R"

Turn the start key (8) in "R" position and carry out the following checks:

- lamp panel (figure 7)
- correct run of all control switches (figure 8)
- front lights and turn indicators (figure 9)
- rear lights and turn indicators (figure 10)
- emergency lights
- hydraulic oil level (figure 11)
- acoustic warning signal (horn)
- reverse gear warning beeper

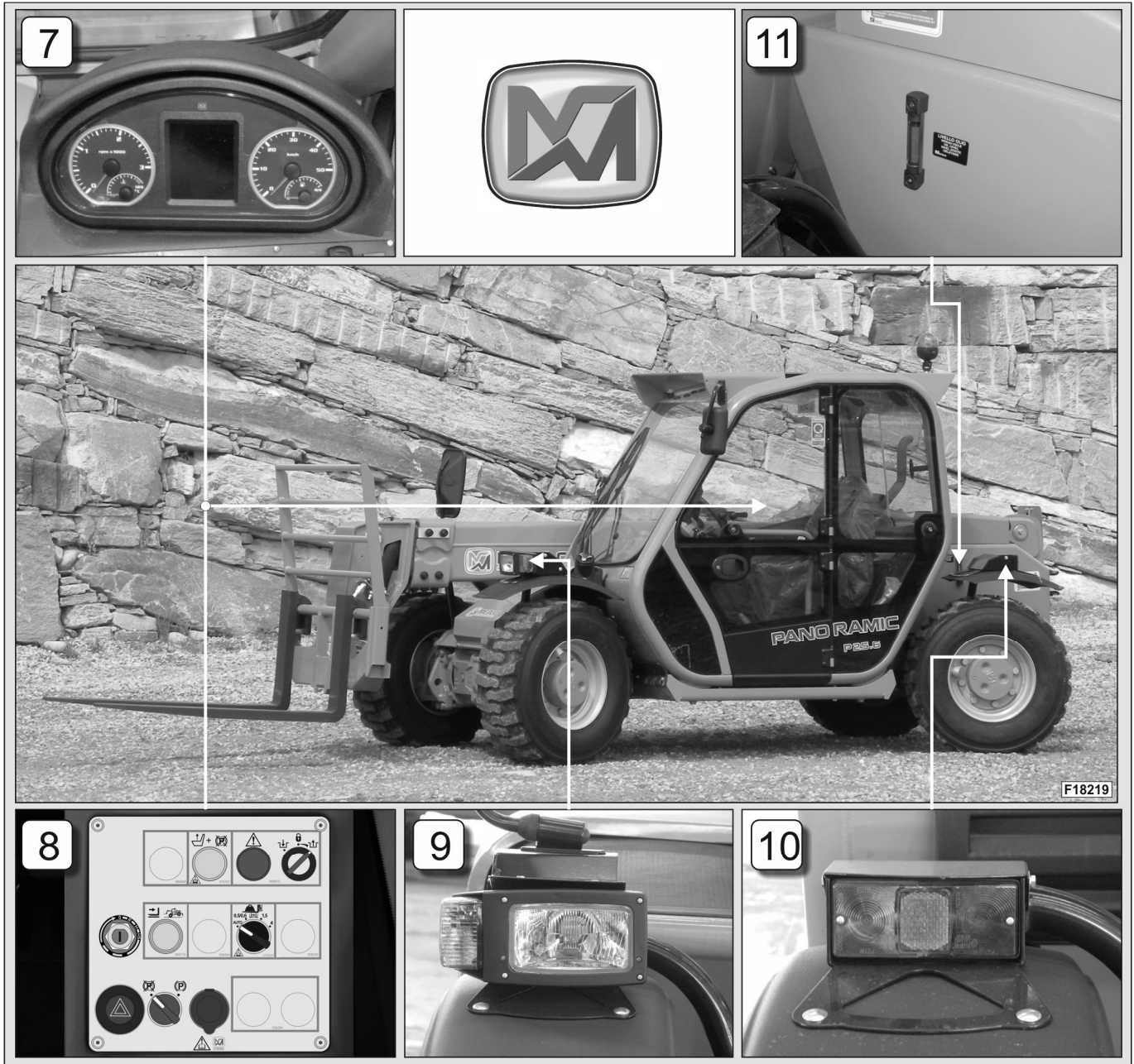



• TURNING ON THE INSTRUMENT PANEL

Per accendere il quadro di comando della macchina ruotare la chiave d'avviamento (8) in posizione "R".

All the warning lights and indicators on the instrument panel illuminate for a short time (GENERAL CHECK function), then all but the following switch off:

- 44 - battery charge warning light
- 45 - engine oil pressure warning light
- 55 - crab steering warning light
- 57 - parking brake warning light
- 58 - engine coolant thermometer
- 59 - fuel level indicator
- 62 - LCD display
- 208 - steering system pressure warning light

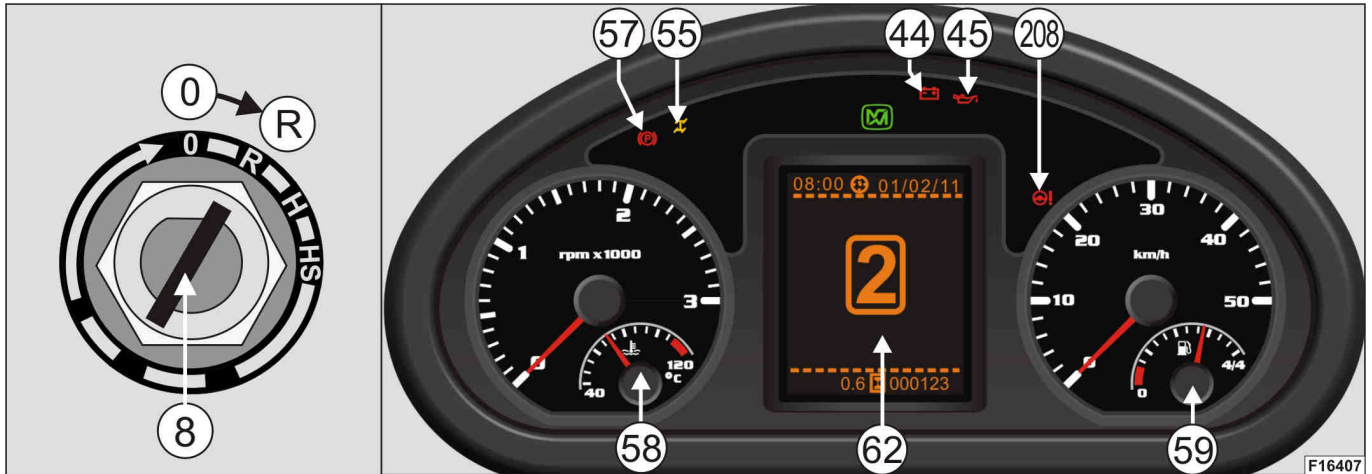

WARNING ! Should the indicators fail to function as indicated, immediately switch off the engine. If the crab steering warning light (55) is lit, use the appropriate lever to reset normal conditions.

• ENGINE START

Before starting the engine, check that:

- parking brake (37) is applied
- drive direction control (20) is in neutral position "N".

Then turn engine start key (8) as follows:

- turn engine start key (8) to position "R" to turn on the instrument panel
- turn engine start key (8) to position "HS" to start the diesel engine; when the engine is running, release key (8), which automatically turns to position "R" again.

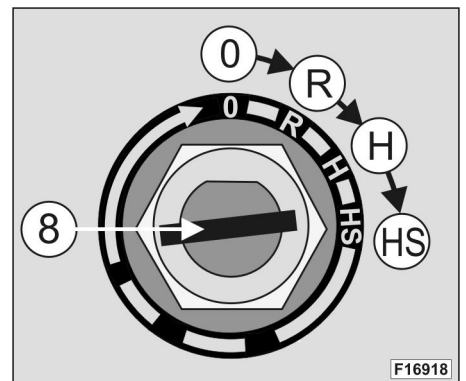

At temperatures of under -5°C (23 °F), it necessary to use the thermo-starter to start up the engine:

- position the key to "R" position
- turn the key in position "H" (indicator (53) will light up) and hold it in this position for approx. 15 seconds.
- Return the key to position "HS" and start the engine



IMPORTANT! Should the engine fail to start after 20 seconds, release engine start key (8). Wait 2 minutes before trying to start the engine again, so as to let the starter cool down.

With the engine running, check that:

- all the warning lights on the instrument panel but the parking brake warning light (57) switch off
- both the engine rpm indicator (61) and the hour counter/odometer (62) start working



Before driving your machine, check that:

- both the acoustic alarm and the indicator lights on both the instrument panel and the control panel are off
- the controls of the hydraulic system are in working order
- both the service brake and the parking brake are perfectly efficient (for further information please refer to chapter "PERIODIC SAFETY CHECKS")
- the fuel tank is full enough

• MACHINE START



NOTE! Depending on ground conditions, the machine could start moving before the operator is ready. The procedure described below grants the full control of the operator on the machine.

With the engine running, follow the procedure below:

- check that the wheels are aligned with the frame.
- select the required steering mode.
- press and hold the service brake pedal (15)
- release the parking brake
- select the drive direction with the drive direction control (20)
- gradually press the accelerator pedal (14), while releasing the brake pedal (15) at the same time



WARNING! The machine is fitted with a system which activates the intermittent sound alarm when, while the parking brake (37) is applied, the drive direction control (20) is activated.

• STOPPING THE ENGINE AND PARKING YOUR MACHINE

When you stop the engine and park your machine at the end of a working day, carry out the following operations:

- Shift the drive direction selector to the "N" position.
- Apply the parking brake.
- Fully retract the telescopic boom.
- Lower the forks to the ground.
- Let the engine idle for 2 minutes before switching it off.
- Turn the engine start key (8) to the "0" position; the engine switches off automatically
- Remove the engine start key (8) from the dashboard.
- Bleed air from the boom extension cylinder by moving its control lever forward and backwards.
- If your machine is equipped with chocks, chock the wheels.
- Lock the cab door.

• CHECK CONTROL

The system warns the operator about a malfunction by setting off an alarm and switching on the corresponding warning light. The following warning lights fall within this GENERAL CHECK:

- 44 - battery charge warning light
- 45 - engine oil pressure warning light
- 46 - brake oil level warning light
- 47 - engine air filter warning light
- 48 - hydrostatic transmission oil level warning light
- 49 - hydrostatic transmission oil temperature warning light
- 57 - parking brake warning light
- 93 - engine coolant warning light
- 132 - engine coolant level warning light
- 133 - water in the diesel oil warning light
- 206 - break in the ropes warning light
- 207 - MERLO SERVICE reminder warning light
- 208 - low steering system pressure warning light

For further information about the warning lights involved in the GENERAL CHECK please refer to the instructions provided in table "WARNING LIGHTS AND INDICATORS ON THE INSTRUMENT PANEL", paragraph "DESCRIPTION OF THE INSTRUMENT PANEL (C)", chapter "CONTROLS AND INSTRUMENTS".

In any case the operator shall switch off the engine immediately, and troubleshoot the problem (for maintenance operations please refer to the corresponding chapter).



INSTRUCTIONS FOR DRIVING YOUR MACHINE ON THE ROAD



WARNING! Observe the laws in force.

The circulation on public road of the machine is allowed only in compliance and fittings reported in the road circulation documents. Lock the working tools with the special locking devices and install any prescribed protective devices.

The transport of loads on public roads is strictly forbidden.

You are reminded that the circulation of the machine on public roads with forks mounted is forbidden.

Before driving your machine on the road you need to:

- make sure that the tyres are inflated to the correct pressure (as shown on the sticker applied on the rim), and that they are in perfect condition for use
- make sure that all visual and acoustic alarms are clean, in working order, and in perfect condition for use
- make sure that all the windows and the rear-view mirrors of your machine are clean, and that the latter ones are correctly adjusted
- make sure that the flashlight on the roof is correctly installed and in working order
- make sure that the fuel tank is full enough
- align the wheels with the chassis and select front-axle steering
- fully retract the telescopic boom, then lower it until the red stripe applied on the cab window (to the operator's right) is aligned with the red stripe applied on the telescopic boom
- make sure that the tool-holder carriage is perpendicular to the ground: the carriage is in the correct position if the red stripe on the carriage is aligned with the one on the boom head (see corresponding paragraph)
- turn operating mode selector key (6) to position "B" (the controls of the hydraulic system are disabled)
- switch on the rotary flashlight, and make sure it works by daylight too
- switch on the low-beam headlights (if this is prescribed by the local highway code)
- close the cab door

• BOOM POSITIONING FOR ROAD CIRCULATION

For road circulation you have to completely retract the telescopic boom, then lower it till the red line and the ref. point on the chassis (A) are aligned.

Check also that the carriage is perpendicular to the ground: the correct position is given by the alignment between the two red lines (B) on the carriage and on the boom head.

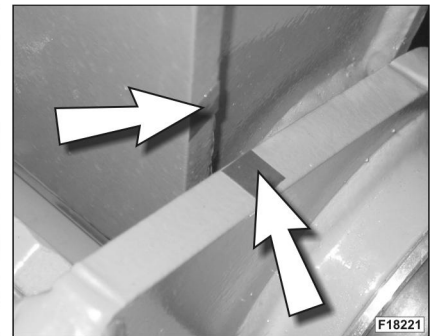
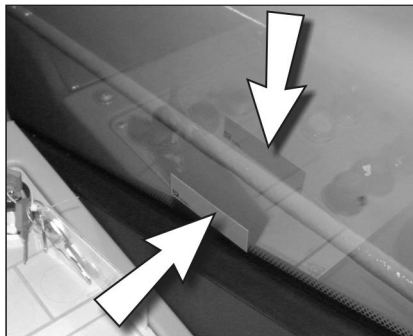

• GRADEABILITY

Gradeability and pick and carry information is shown in the load charts of your machine, and depend on work conditions and on the type of attachment installed.

Constantly monitor machine operating slope with the 2 spirit levels available in the driver's cab. Use precision level 'Y' for slight slopes (<math><5^\circ</math>), and main level 'X' for steep slopes (>math>>5^\circ</math>). For further information on the spirit levels installed in the driver's cab please refer to paragraph 'LATERAL AND LONGITUDINAL SLOPE INDICATORS'.



• TOWING OF THE MACHINE

The vehicle can be towed only if it is not possible to act differently. If possible, it is advisable to use the suitable aid equipment. Keep in mind that the towing force must be, at least, 1500 kg (3310 lb)

GENERAL INSTRUCTIONS FOR MACHINE TOW

- to tow the machine use the coupling points available for this purpose
- never use cables, belts or chains to tow the machine or to have it towed, since they can break
- never use cables, belts or chains to tow the machine or to have it towed if the braking system of the machine does not work
- always use a stiff, properly sized bar to tow the machine
- during machine tow an operator shall always be sitting in the vehicle being towed
- never stand near vehicles while they are being towed
- the machine can be towed for short stretches by vehicles having the right size and weight and being compliant with the national law as it stands

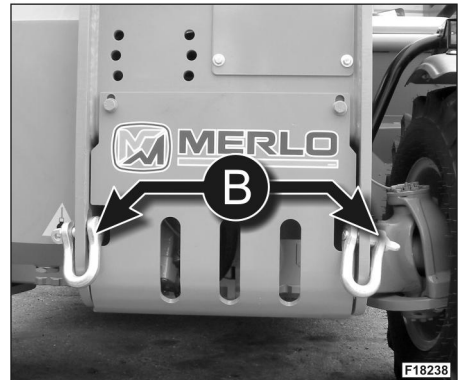
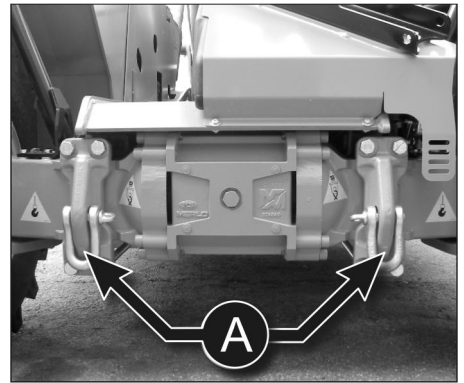

PREPARING THE MACHINE FOR BEING TOWED

- Hitch the machine either from its front side, through holes "A", or from its rear side, through holes "B"
- Turn the steering wheel until the rear wheels are parallel with the side of the machine.
- Select front-axle steering.
- Should the battery be completely flat, connect an external one, as described in chapter "FAILURES - CAUSES - REMEDIES" of this manual, in paragraph "HOW TO START THE ENGINE WHEN THE BATTERY IS FLAT".
- Shift the drive direction selector (20) to the neutral position.

Release the parking brake following these instructions:

- Turn the starting key to position R.
- Turn the (37) selector towards left.
- Act on the emergency pump (28) in order to open the brake caliper (the selector 37 stop lightening).
- In case it is not possible to disable the hand brake, go on as described in the chapter "FAILURE - CAUSES - REMEDIES" of this manual at the paragraph " MALFUNCTIONING OF THE EMERGENCY PUMP".

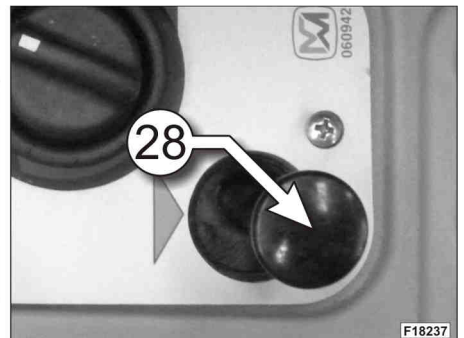
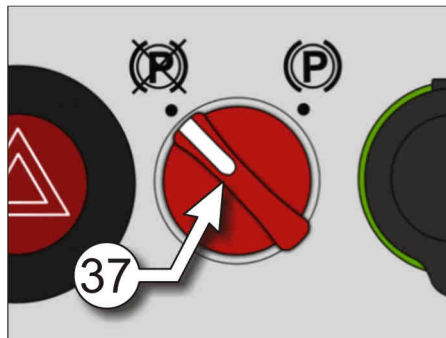

In order to tow the machine either forward or backwards, you need to enable the bypass of the pressure relief valves of the hydrostatic pump.

- in order to tow the machine backwards, you need to enable the bypass of the upper pressure relief valve of the hydrostatic pump, which is located under the engine bonnet (Fig. 1)
- in order to tow the machine forward, you need to enable the bypass of the lower pressure relief valve of the hydrostatic pump, which is located under the cover beneath the hydrostatic oil filter (Fig. 2)

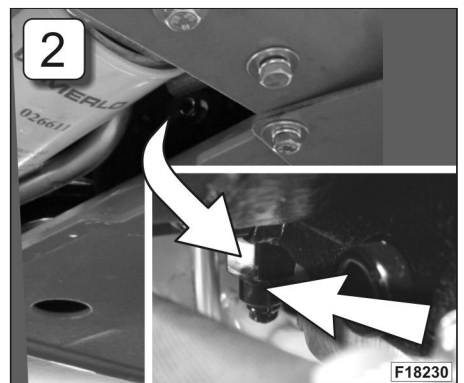
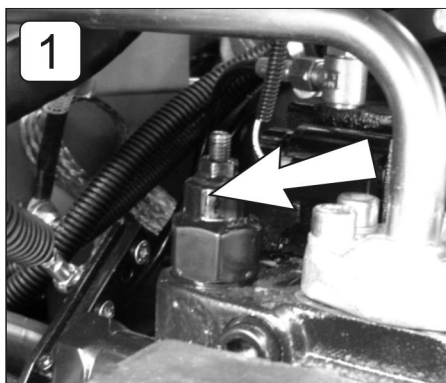



Once you have identified the pressure relief valve you need to bypass, proceed as follows:

- loosen check nut "2" (with a 13 mm wrench) which locks in place the dowel of the pressure relief valve you need to bypass (depending on the direction in which you need to tow your machine).
- while holding the check nut steady, screw dowel "1" clockwise (with a 4 mm Allen wrench) until the force required for screwing increases significantly (contact between the dowel end and the valve slider); once this condition is met, keep on screwing clockwise by another 1.5 turns (bypass opening is actuated).
- tighten check nut "2" by rotating it clockwise with a torque of 22 Nm (Fig. 3)



CAUTION! While towing your machine, always keep speed below 2 kph and move your machine just enough to leave the danger area. In any case, never tow your machine for longer than 100 metres.

Towing your machine either at a higher speed or for a longer distance may overheat the hydrostatic motor, with a consequent damage to pistons.

While towing your machine, the components described in this paragraph may overheat. Always wear protective clothing!

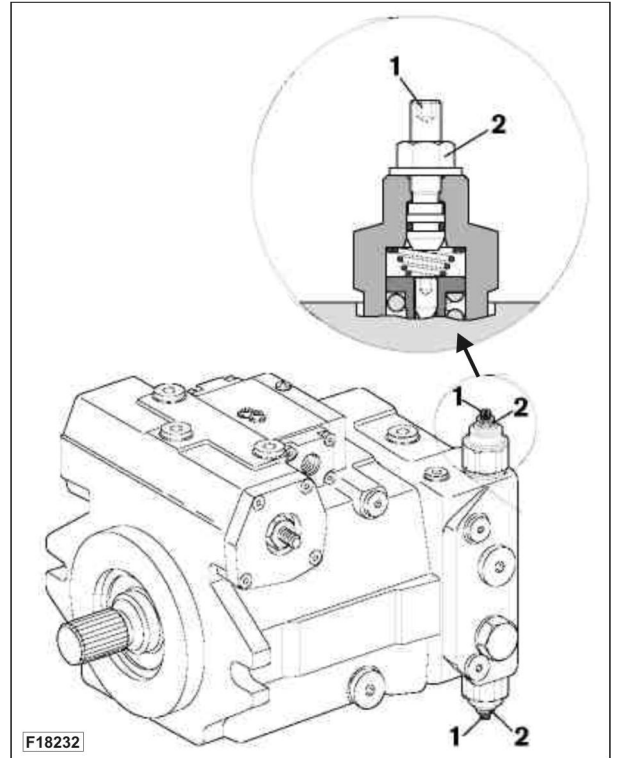

When you finish towing your machine, disable the bypass function by carrying out the operations described above in reversed order:

- loosen check nut "2" (with a 13 mm wrench)
- unscrew dowel "1" completely (with a 4 mm Allen wrench), by rotating it counter-clockwise up to the end of its thread
- tighten check nut "2" by rotating it clockwise with a torque of 22 Nm



NOTE! When you restart the engine after towing your machine, first drain the hydrostatic transmission system as described in paragraph "EVERY 1500 HOURS - HYDROSTATIC TRANSMISSION OIL", chapter "ROUTINE MAINTENANCE".

• HOW TO ANCHOR YOUR MACHINE

Use the anchoring points shown below to anchor your machine (e.g. to lock it in place on a trailer for transport):

- C) front anchoring points
- D) rear anchoring points

PREPARING YOUR MACHINE FOR BEING ANCHORED

- install proper shackles in each of the indicated points
- tie either ropes or chains to the shackles, and check that they don't come into contact with machine surfaces

• LIFTING THE MACHINE

- Disassemble the vehicle attachments
- Assemble suitable clevis in each of the shown points
- Lower and completely retrieve the vehicle boom
- Clamp the ropes to the previously assembled clevis.

The vehicle total weight is written on the identification label outside the cab. Keep in mind that each clevis and its rope must have a min. lift capacity more than 2/3 of the vehicle total weight. The attachments must be lifted separately from the vehicle and following the instructions of the pertaining chapter in this handbook or in the enclosed booklets.



WARNING! Check that ropes, clevis and lifting devices are in good condition and that their lift capacity is sufficient for the weight to be handled.

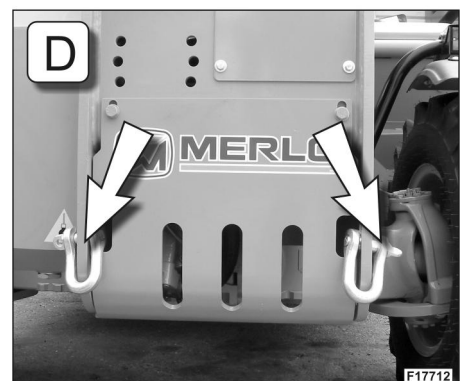
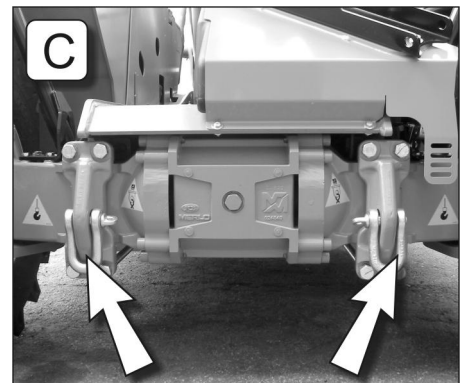



• TRANSPORTING OF THE MACHINE

- Load and unload the machine on a firm and level surface.
- Ensure that truck and trailer are braked.
- Use a ramp or loading deck. Ramp must be strong enough, have a low angle, and correct height.
- Drive the machine into the ramp squarely.
- Park the centre of the machine over the centre of the trailer bed.
- Put chock blocks in front and back of wheels.
- Shift gear box and forward/reverse selector to neutral position.
- Apply parking brake.
- Lower the boom until the forks lay on the trailer.
- Stop the engine, and remove the key.
- Lock the cabine door.
- Fasten the machine to the trailer with chains or cables



WARNING ! Do not use parking brake only but lock the machine to the trailer by external means.

INSTRUCTIONS FOR A CORRECT MACHINE USE IN THE VICINITY OF ELECTRICITY POWER SUPPLY LINES

Before setting to work, check that there are no overhead utility lines in that area.

Should there be overhead utility lines, keep a safety distance from them (at least 5 metres (16 ft)).

However, you are advised to inquire the minimum safety distance from such lines from the manager of said lines, as well as from the authorities in charge of safety and health in the workplace.

Please note that the higher the voltage, the greater should the safety distance be

USE OF THE MACHINE DEPENDING ON WIND STRENGTHS

Before using the machine, check whether wind strengths allow you to work safely at a certain height.

Read the following table - showing the Beaufort scale - to estimate wind strengths.



WARNING!

The maximum permissible wind strength for the operation of the access platform is 12.5 mps (28 mph)

This table is also available as a leaflet, to be found in its holder both in the cab.

INSTRUCTIONS FOR A CORRECT USE OF THE TABLE:

- up to class 4 working conditions are good (green symbol)
- class 6 indicates that you are working under risky conditions for the machine. The yellow-red symbol indicates that you should work with extreme caution, especially if you are working at a significant height
- from class 7 on (Beaufort scale has 12 classes) the machine shall not be used



WARNING!

Never equip your machine, its parts and attachments subject to the action of the wind with components or materials (such as panels, sheets or the like) which might have a "sail effect" and decrease machine stability in windy days.

MERLO S.p.A. Industria Metalmeccanica			
BEAUFORT WIND SCALE			
FORCE	DESCRIPTION	SPEED [m/sec]	OBSERVED EFFECTS
0	CALM	0 - 0,2	Smoke rises vertically
1	LIGHT AIR	0,3 - 1,5	Smoke drifts; leaves barely move
2	LIGHT BREEZE	1,6 - 3,3	Leaves rustle; wind can be felt
3	GENTLE BREEZE	3,4 - 5,4	Leaves and twigs move; debris and dust raised from ground
4	MODERATE BREEZE	5,5 - 7,9	Small branches move; debris and dust raised from ground
5	FRESH BREEZE	8 - 10,7	Small trees sway and large branches in motion; dust clouds raised
6	STRONG BREEZE	10,8 - 13,8	Large branches continuously move; wind whistles; difficulty using and umbrella
7	MODERATE GALE	13,9 - 17,1	Large trees sway; difficulty walking



**VISIBILITY**

The truck is fitted with visibility aids which the operator must avail himself/herself of in order to safely operate the truck and the handling of loads. Such visibility aids are:

- left-side rear-view mirror
- right-side rear-view mirror

MAIN SAFETY RULES AND WARNINGS

Before operating the truck carefully check the working area to ensure the absence of people or obstructions in the operating range of the truck. Before operating the truck check that all visibility aids are present and in good condition. If the visibility aids are damaged or incomplete remove the machine from use and inform the management.



IMPORTANT! In no circumstances operate the truck with any visibility aids missing or damaged.

In case any of the visibility aids have become misaligned (e.g. as a result of a collision or other incident), follow the procedures described in the "VISIBILITY AIDS MAINTENANCE" to check and, if necessary, realign the devices. When operating the truck, continually monitor the working area to make sure that no personnel enter the working zone.



IMPORTANT! Always sit in the correct driving position to operate the truck.

To sit correctly in the driving position ensures sufficient direct visibility to safely operate the truck and to avoid contacts with personnel or obstructions. If a suspended load or the resulting boom geometry creates a substantial blockage, consider alternative carrying means (e.g. palletised load).



WARNING! The operator is advised against using the truck with the boom raised at an angle so as to have the upper face of the forks at a height of 1000mm ± 50 mm from the ground with the boom fully retracted because it creates substantial masking of the operator's visibility to the right side of the truck.

Use the telescopic boom facility of the truck for loading or unloading instead of moving the truck with the boom in this position. If it's necessary to work with the boom raised at an angle so as to have the upper face of the forks at a height of 1000mm ± 50 mm from the ground with the boom fully retracted:

- before operating the truck be sure that no personnel are in the working zone. If possible, mark-off the working area using cones or other barriers to exclude personnel and vehicles from it;
- operate with extreme caution.

Check - and if necessary realign - the visibility aids periodically as described and scheduled in the "VISIBILITY AIDS MAINTENANCE" section.



IMPORTANT! Modifications of the truck may affect the operator's visibility.

VISIBILITY AIDS POSITIONING

Before operating the truck for the first time, or following a long downtime period, perform the visibility aids positioning procedures as described in the following sections.

To correctly adjust the mirrors position, a second person (the "adjuster") will be required to make the adjustments, following the instructions received by the operator in the cab.

All procedures should be performed with the engine off and the boom fully retracted and lowered.





LEFT-SIDE REAR-VIEW MIRROR

The adjuster should:

- turn the mirror support to the locked position;
- once in the locked position, not disturb the mirror support through the rest of the procedure;
- rotate the mirror about its axis of rotation following the instructions from the operator in the cab

The operator in the cab should:

- sit correctly at the driving position;
- close the door;
- instruct the adjuster to rotate the mirror about its axis of rotation until the left rear edge of the cab is seen in the right (inner) edge of the mirror surface.

RIGHT-SIDE REAR-VIEW MIRROR

The operator in the cab should:

- sit correctly at the driving position;
- instruct the adjuster to rotate the mirror about its axis of rotation until the right side of the truck is seen in the left (inner) edge of the mirror surface.

The adjuster should:

- rotate the mirror about its axis of rotation following the instructions from the operator in the cab.

MAINTENANCE OF VISIBILITY AIDS

The following are the maintenance checks, procedure and schedules necessary to maintain the visibility aids in a safe condition.



IMPORTANT! Do not operate the truck until all the maintenance procedures described herein have been performed.



REAR-VIEW MIRRORS

Every day, before using the truck:

- check the presence and integrity of the rear-view mirrors;
- ensure the reflecting surfaces are clean. If necessary clean them taking care to remove any accumulated debris;
- carefully dry the reflecting surfaces after the cleaning.



WARNING! During cleaning operations the position of rear-view mirrors may be unintentionally changed. Always check the correct position of the rear-view mirror, according with the procedure described in the "VISIBILITY AIDS POSITIONING" section, after cleaning.

Every 15 days:

- check the positioning of the rear-view mirrors and adjust if necessary using the procedure described in the "VISIBILITY AIDS POSITIONING" section.

IMPORTANT RESIDUAL HAZARD WARNINGS CONCERNING VISIBILITY FROM THE CAB AND RELATED INDICATIONS

When using the truck in the conditions described in this section, pay attention to the following important residual hazards concerning visibility from the cab and to their related indications.

LADEN TRANSPORT CONDITION



WARNING! When transporting a load in the laden transport condition, with the upper face of the forks at a height of about 500mm ± 50 mm from the ground, the load and the upper part of the boom head may reduce the long-range visibility to the front right-side of the truck.

In this case, travel slowly and pay particular attention to the front right-side when steering to the right.



SUSPENDED LOADS



WARNING! When handling a suspended load with the boom raised at an angle so as to have the upper face of the forks at a height of about 2200mm \pm 50 mm from the ground, the rear part of the truck and the boom position may reduce visibility to the rear and right-side of the truck.

In this case, travel slowly and refer to the right-side rear-view mirror to ensure visibility to the right-side of the truck. If the suspended load or the resulting boom geometry creates a substantial blockage, consider alternative carrying means (e.g. palletised load).



WARNING! When handling a suspended load with the boom raised at an angle so as to have the upper face of the forks at a height of about 2200mm \pm 50 mm from the ground, the boom position and the rear part of the truck may reduce long-range visibility to the front right-side of the truck.

In this case, travel slowly and pay particular attention to the front right-side when steering to the right.

REVERSE TRAVEL CONDITION



WARNING! When travelling in reverse, the rear part of the truck partially masks visibility to the rear.

In this case, travel slowly and carefully monitor by direct visibility the rear of the truck paying particular attention to the rear right-side of the truck assisted by the right-side rear-view mirrors if necessary.

TRAILER LOADING OR UNLOADING



WARNING! When using the truck with the boom raised at an angle so as to have the upper face of the forks at a height of about 1000mm \pm 50 mm from the ground with the boom fully retracted, the boom creates substantial masking of the operator's visibility to the right side of the truck.

It is advised against moving the truck with the boom in this position. Use the telescopic boom facility of the truck for loading or unloading.

REARVIEW CAMERA

Your machine is equipped with a rearview camera 'A' to make backup manoeuvres easier. It can be switched on in 2 different ways:

- 1) manually: press button 'P2' on display (D) in the driver's cab until the channel connected to the rearview camera is switched on.
- 2) automatically: turn drive direction selector (20) to the 'R' position. The rearview camera automatically switches on.

The rearview camera can be switched off:

- 1) manually: press button 'P1' on display (D) in the driver's cab .
- 2) automatically: turn drive direction selector (20) to either the 'N' or the 'F' position.

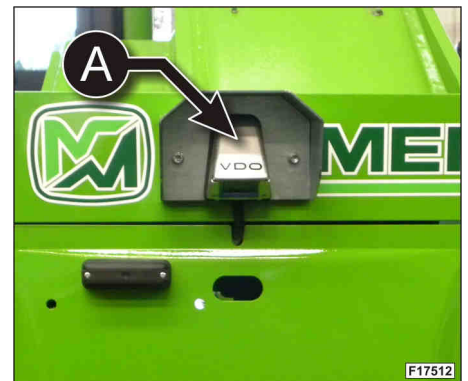



EXTERNAL LONGITUDINAL STABILITY INDICATORS

An indicator light is available on the roof of your machine. Its three lamps (green, amber and red) show the stability conditions shown on display (D). This information helps the operator who is standing outside the machine to show the other operator (who is sitting in the driver's cab) the necessary manoeuvres for load handling (see figure 1 for the correct position of the operator outside the machine).

The 3 stability conditions are as follows:

- green lamp on (A): the machine is stable, no movements are locked
- amber lamp on (B): the machine is getting close to its longitudinal stability limit, but no movements are locked
- red lamp on (C): the machine has reached its stability limit, and as a consequence all aggravating movements are locked

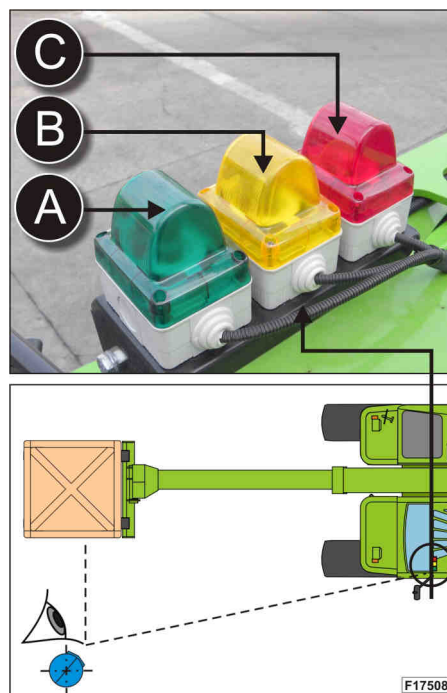

PICK AND CARRY

The PICK AND CARRY operating mode refers to load transport with the machine in motion. All the information on machine use is provided both in the load charts available in the driver's cab and in the Operator's Manual, chapter 'ATTACHMENTS AND OPTIONAL VARIANTS'.

The M-CDC system automatically recognizes the PICK AND CARRY mode based on both the attachment installed on the machine and the drive direction selected. It allows this mode to be used with the telescopic boom fully retracted and lifted by up to 50°. Outside this operating area the use of the PICK AND CARRY mode is not allowed. The operator is informed about it through an information screen on display (D).

If attachments with oscillating loads are used, the maximum capacity in the PICK AND CARRY mode can be reduced. This value is shown in the attachment-specific load charts.



NOTE! *The maximum capacity of your machine in the PICK AND CARRY mode can be reduced if the DE-RATING mode is enabled.*

END OF CHAPTER



INDEX

INTRODUCTION	2
SAFETY INFORMATION AND GENERAL RULES	2
ENVIRONMENTAL INFORMATION	2
INFORMATION ON ORIGINAL MERLO SPARES	2
MAINTENANCE INFORMATION	2
MECHANICAL RETAINER FOR THE LIFT CYLINDER	3
FUEL AND LUBRICANTS	3
SCHEDULED MAINTENANCE DURING THE MACHINE BREAK IN PERIOD	6
COVERS.....	9
NOMENCLATURE - ENGINE COMPARTMENT	10
GREASING POINTS ON YOUR MACHINE.....	11
MERLO PERIODIC MAINTENANCE PROGRAMME	13
DAILY OR EVERY 10 HOURS	15
EVERY 50 HOURS OR WEEKLY	16
EVERY 500 HOURS OR EVERY 6 MONTHS	20
EVERY 1000 HOURS OR EVERY 12 MONTHS	25
EVERY 1500 HOURS.....	27
GENERAL MAINTENANCE.....	30
TROUBLE SHOOTING	34
END OF CHAPTER	35



INTRODUCTION

In this chapter you will find all the ordinary maintenance operations to be executed both during the running in period and periodically. Moreover, you can find all information concerning type of fuel, greases and oils to be used on your machine in order to assure the highest reliability, efficiency and lifetime.

SAFETY INFORMATION AND GENERAL RULES

To be sure the machine is used in maximum safety, reliability and efficiency conditions, it is fundamental to regularly carry out the ordinary maintenance interventions and to closely follow the instructions provided in this Operator Manual.

Do not use the machine until all needed maintenance operations and repairs have been carried out.

If the operator detects that the machine operation is not optimal and does not meet safety requirements, the fault shall be immediately notified to the responsible person.

Before carrying out any intervention on the machine, it is necessary to stop the engine, position the driving direction selector in central position and the gear selector in neutral position.

It is strictly forbidden and highly dangerous to change any machine component by modifying its original structure. It is also forbidden to change the hydraulic and electric settings or to alter the safety systems. Otherwise, Merlo S.p.a shall be waived of any liability and guarantee claim.



WARNING! Maintenance operations shall be executed by skilled and competent personnel. For interventions on components which are excluded from the ordinary maintenance described in this Manual, contact Merlo Technical Support Service.

ENVIRONMENTAL INFORMATION



WARNING! Always comply with the environmental laws of the country where the machine is used.

It is strictly forbidden to unload or discharge oils, filters or any other source of environmental pollution. Pay particular attention to safe waste disposal of such materials which are dangerous for people and the environment – in such cases, contact the responsible organisations.

When handling lubricants, wear all appropriate personal protection devices (gloves, masks, overalls, etc.).

In order to avoid any personal burns or fires, do not work on heated fluids or components.

INFORMATION ON ORIGINAL MERLO SPARES



WARNING! Maintenance operations on Merlo machines must be carried out using only original and approved spares. If non original spares are used, Merlo shall be waived of any liability and all machine guarantee terms shall be voided.

MAINTENANCE INFORMATION

In case of machine failure, the operator shall switch off the diesel engine as soon as possible, take out the engine start key, get off the machine and check the extent of the problem. Please note that maintenance operations shall be carried out by skilled, trained personnel when the machine is standing still.

All maintenance operations shall be carried out indoor, in a properly equipped workshop. Before starting any maintenance operation, please make sure that the following conditions are met:

- never carry out maintenance operations you are not familiar with. Always follow the instructions provided in the Operator's Manual and, if necessary, contact the Merlo Technical Support Service.
- place the machine on a flat, compact ground, having a maximum slope of 3%.
- retract and lower the telescopic boom of the machine completely.
- remove any loads or attachments fitted on the machine and place them on the ground.
- shift both the gearbox selector and the operating mode selector to the neutral position.
- switch off the diesel engine and take the engine start key out of the dashboard.
- with the engine off, operate the control levers to relieve any residual pressure from the oil circuit.
- place wheel chocks under both front and rear wheels of the machine to prevent accidental movements.
- always use personal protection devices (accident prevention shoes, gloves, dust mask, etc.).
- take all the necessary accident prevention measures for the kind of operation to be carried out.
- only replace lubricating oil when its temperature drops below 60°C (140 °F)
- carry out all maintenance operations at least 4 hours after switching off the engine, so that any contact with hot machine parts can be avoided.
- when using compressed air for cleaning and blowing operations, make sure that the maximum pressure is 2 bar (29 psi). Always wear protection goggles when using compressed air.
- use either a ladder or an access platform - compliant with the law as it stands - if you need to carry out maintenance operations on the machine at a height exceeding 1.50 m (5 ft) from the ground.



- if you need to carry out maintenance operations underneath the machine, use either a pit or an auto lift having proper features. For the total weight of the machine please refer to the identification plate applied on the outside of the cab.
- if you need to raise the telescopic boom to carry out maintenance operations, equip the working area with external supports which can support the telescopic boom and prevent it from being lowered accidentally. For this purpose connect a sling to a suitable hoisting device having a minimum load capacity of 2,000 kg. (4,400 lb)
- if you need to lift the machine from the ground to carry out maintenance operations, use a suitable lifting device which complies with safety rules; the coupling points on the machine are shown by a yellow triangular sticker.
- before carrying out any maintenance operations on either a tire or a rim, deflate the tire completely.
- while inflating tires, never stand in front of the tire sidewall; place yourself sideways.
- never make welds on the rim if the wheel is still mounted on the machine, since this may lead to either an explosion or a fire.
- avoid any prolonged, repeated contact between your skin and fuels, lubricants or other fluids, since this may cause skin disorders or other syndromes.
- never ingest fuels, lubricants, or other fluids.
- during filter cleaning or replacement, make sure that the room is properly ventilated, in order to prevent toxic fumes from accumulating.
- never make welds in enclosed rooms which are not properly ventilated.
- never make welds on painted surfaces. Remove the paint with suitable products first, then wash the surfaces and let them dry.
- be careful when removing caps from tanks, radiators, or cylinders: turn them cautiously to relieve any residual pressure.
- stay out of the way during draining operations, and always wear protection goggles. Slowly unscrew the draining screw by a few turns to let either the condensate or the fluid come out.
- relieve pressure from circuits before carrying out maintenance operations.
- never try to identify leaks of pressurized fluids with your bare hands.

MECHANICAL RETAINER FOR THE LIFT CYLINDER

If you need to carry out maintenance work on your machine with the boom raised, first you have to apply mechanical retainer 'A' supplied with your machine. When in its home position, this retainer is placed on the front left mudguard.

To remove the mechanical retainer from its home position carry out the following operations (picture 1)

- remove split pins 'B'
- remove pins 'C'
- pick up mechanical retainer 'A' from its handles

To apply the mechanical retainer on the lift cylinder, follow the instructions below:

- fully raise the telescopic boom of your machine
- place mechanical retainer 'A' around the lift cylinder, as shown in picture 2
- insert fastening pins 'C'
- insert split pins 'B'

After completing all maintenance operations, put the mechanical retainer back to its home position by carrying out the operations above in reversed order.

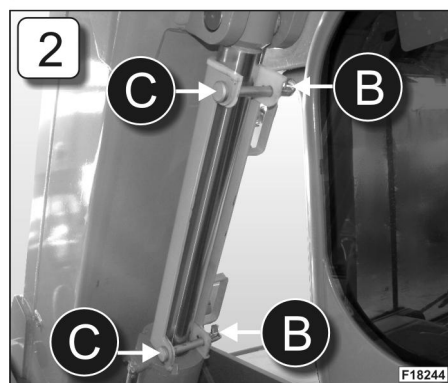
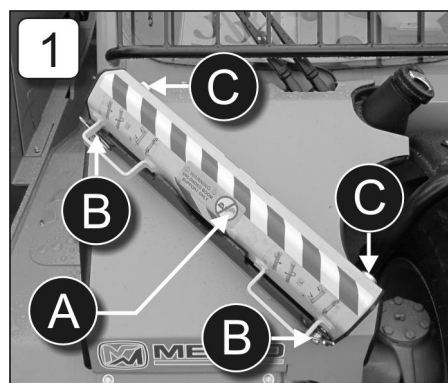

FUEL AND LUBRICANTS

Please follow these descriptions in order to know type of fuel, oils and greases to be used on your machine.

• DIESEL FUEL

For further details consult the manual of the relative engine.

- FUEL STORAGE

Carefully observe the following rules to correctly store the fuel:

- Store the diesel fuel in clean containers, away from direct sunlight and in a protected area.
- Before refuelling the machine, eliminate any dirt, water or sediment in the deposit tanks, as these may obstruct filters, the injection pump or injectors. This is particularly needed if diesel is stored for a long period of time.
- Do not use antifreeze to extract water from diesel
- Do not rely only on the pre-filter found on the machine to completely eliminate water from the diesel fuel.

**- FUEL TANK FILLING**

Refuel with diesel at the end of each working day.

To carry out a correct refuelling procedure, follow these instructions:

- Carefully clean the area of the fuel cap.
- Remove the fuel cap "T" by releasing its lock with the provided key.
- Insert the diesel fuel into the tank by making sure not to fill it up to its brim, as it is necessary to leave some free space to accommodate for fuel expansion. Immediately clean any spilled fuel.
- Screw the fuel cap "T" and close its lock with the provided key so as to prevent any tampering.

Fuel tank capacity = 70 lt (18 gal)

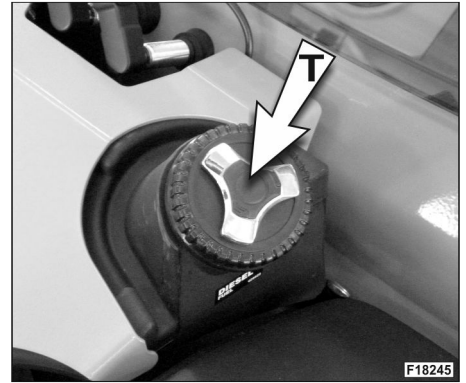

WARNING! Handle the fuel with great care. Before refuelling with diesel, stop the engine.

Do not smoke while filling up the tank or while working on the fuel system.

Do not refuel or pour fuel in closed or not sufficiently aired environments.

In the cold season, only use diesel additioned with winter additives.

- ANTI FREEZE

Refer to the relative engine workshop manual.

- OILS CHART - for use of the machine in normal temperatures (0°C, + 40°C) (32°F, 100°F)



WARNING! The oil to be used for replacement or topping up, may be selected from those recommended by the manufacturer or other types available on the market, it must however comply with the characteristics indicated in the table.

Although it is not possible to mix different oil brands, it is possible to top up the oil using a different brand to that inside the system, providing that it complies with the specifications indicated and that the quantity required does not exceed 10% of the total capacity of the system.

Different brand oil cannot be mixed.

Oil transportation and trade must be subject to European and local laws in force. Customers are kindly requested to act for their supply following the mentioned rules. For check and replacement operations refer to the information in the instruction handbook.

The oils chart is also enclosed, as a booklet, in container (21) inside the cab (please see Chapter "STICKERS WITH CONTROL DESCRIPTIONS - LEAFLETS IN THE CABIN").

ENGINE OIL			SPECIFICATIONS
ENGINE	SAE 10W-40		ACEA E3/E5/E7
COOLANT	COLOR: RED -35%- TEMPERATURE UP TO -25°C		ASTM D4985 VW TL 774D MB325.3

HYDRAULIC CIRCUIT OIL					
	ESSO	MOBIL	SHELL	Q8 OILS	SPECIFICATIONS
HYDRAULIC	HYDRO HVI 46 UNIVIS N46	DTE 15 M	TELLUS T 46	Q8 HANDEL-46	VISCOSITY at 40°C = 46cst Iso 3448 = 46
SERVICE					
HYDROSTATIC TRANSMISSION					

BRAKING CIRCUIT OIL					
	ESSO	MOBIL	SHELL	Q8 OILS	SPECIFICATIONS
BRAKING CIRCUIT	BRAKE FLUID SUPER	MOBIL BRAKE FLUID	BRAKE FLUID DOT 4	_____	In conformity FM VSS 116 DOT 4



MECHANICAL GROUPS OIL					
	ESSO	MOBIL	SHELL	Q8 OILS	SPECIFICATIONS
DIFFERENTIALS	ESSO GEAR OIL GX 80W/90	MOBILUBE HD 80W-90	SPIRAX HD	Q8 T 55 80W-90	SAE 80W-90 MIL-L-2105C
REDUCTION HUB					

- OILS CHART - for use of the machine in Arctic temperatures (-15°C, + 30°C) (4°F, 86°F)

For different brands of oil, ensure that they have characteristics equal to the above ESSO products. Should you wish to change the product brand, the system must be flushed clean of the original fill product. In case of use of oils of different characteristics, any claim will be automatically refused.

ENGINE OIL	
ENGINE	Refer to the relative engine handbook.
COOLANT	COLOR: RED -50%- TEMPERATURE UP TO -38°C

HYDRALUIC CIRCUIT OIL		
HYDRAULIC	ESSO UNIVIS N32	Hydraulic oil with viscosity at 40°C = 34,9 c St
HYDROSTATIC TRANSMISSION		High viscosity index ISO 3448 = 32

BRAKING CIRCUIT OIL					
	ESSO	MOBIL	SHELL	Q8 OILS	SPECIFICATIONS
BRAKING CIRCUIT	BRAKE FLUID SUPER	MOBIL BRAKE FLUID	BRAKE FLUID DOT 4	_____	In conformity FM VSS 116 DOT 4

MECHANICAL GROUPS OIL					
	ESSO	MOBIL	SHELL	Q8 OILS	SPECIFICATIONS
DIFFERENTIALS	ESSO GEAR OIL GX 80W/90	MOBILUBE HD 80W-90	SPIRAX HD	Q8 T 55 80W-90	SAE 80W-90 MIL-L-2105C
REDUCTION HUB					

- GREASES CHART - for use of the machine in normal temperatures (0°C, + 40°C) (32°F, 100°F)

APPLICATIONS	PRODUCT	NOTES
Pivot pins, greased joints Boom sliding pads (Internal) Plunger for quick uncoupling of attachments	SPECIAL GREASE ROLOIL TIV SPECIAL-MERLO	
Boom sliding pads (external)	SPECIAL GREASE ROLOIL ULTRAGREASE SPECIAL-MERLO	
Service brake caliper piston seals	PBR Rubber grease (Repcos brake group)	Vegetal



IMPORTANT! "ROLOIL SPECIAL-MERLO" greases have been designed and manufactured especially for Merlo machines. Therefore, to ensure maximum reliability and efficiency of your machine, always use these products only, which shall be ordered from Merlo Technical Support Service.

- GREASES CHART - for use of the machine in Arctic temperatures (-15°C, + 30°C) (4°F, 86°F)

APPLICATIONS	PRODUCT	NOTES
Pivot pins and greased joints	ESSO type CAZAR K2	Calcium, Penetration A.S.T.M.: 280 mm/10

For different brands of grease ensure they have properties equal to and are compatible with the above products.



IMPORTANT! Your machine can operate at top efficiency only if clean lubricants are used. Use clean containers to handle all lubricants. When replacing plastic bushes, always smear pivot pins with grease "ESSO CAZAR K2" thus to avoid oxidation.

SCHEDULED MAINTENANCE DURING THE MACHINE BREAK IN PERIOD

• INTRODUCTION

The instructions indicated below only relate to the maintenance operations during the machine break in period and complement all other maintenance operations described in chapter "ORDINARY MAINTENANCE".

Machine maintenance operations must be carried out by skilled and qualified members of staff in an adequately ventilated environment. The machine must be located on a flat level ground and the diesel engine must be off.

During the first 100 machine break in hours, carefully carry out the following operations:

- Regularly check the coolant level.
- Regularly check the oil level in the hydrostatic transmission and eliminate any leaks. Only use the lubricants recommended in this manual.
- Regularly check the engine air intake filter and make sure it is always in good conditions and free from any clogging.
- Regularly check that there is no oil spillage or leakage from the hydraulic oil system or the brake circuit; if necessary, eliminate the detected fault.
- Regularly check the electrolyte level in the battery and the proper connection of "+" and "-" terminals.
- Grease the indicated points (see also the table below).
- Check the correct tightening of components to the indicated torque (see also the table below).
- Often check warning lights and indicators (light and sound) during operation.
- Accurately warm up the machine systems by executing a few idle movements
- After engine start, slowly warm up the engine, without revving it up.
- Avoid running the engine at maximum power.
- Avoid stressing the brakes.
- Check the tension of auxiliary control belts.
- Pay attention to any fault or defect.



WARNING! For information on the times and interventions to carry out on diesel engines always refer to the provided engine manual. Before carrying out any operation during the break in period, carefully read the related instruction in chapter "ORDINARY MAINTENANCE".

To determine the break in and scheduled maintenance intervals, refer to the counter on the instrument panel.

• MAINTENANCE SCHEDULE FOR THE RUNNING IN PERIOD

PERIOD (HOURS)	COMPONENT	OPERATION
After the first 10 hours	Nuts and bolts of the drive components Wheel columns	Tighten to torque Tighten to torque
After the first 50 hours	Nuts and bolts of the steering components Nuts and bolts fastening the bridge to the frame	Tighten to torque Tighten to torque
After the first 100 hours (servicing coupon)	Cardan joints Hydrostatic transmission oil filter Hydraulic oil return filter	Grease Replace Replace

• SCHEDULED MAINTENANCE AFTER THE FIRST 10 HOURS

NUTS AND BOLTS OF THE DRIVE COMPONENTS

Tighten screws "V" of the cardan joint attachment flanges at a torque of 11,7 kgm (115 Nm) (85 lbf) (n° 4 screws for each of the two cardan joints).





TYRES AND WHEEL COLUMNS

Check the tyre pressure with a pressure gauge and, if needed, inflate them through valve "A".

The correct tyre inflation pressure is indicated on the sticker on the inside of the wheel rim.

Check the correct tightening of the "B" wheel columns. If needed, tighten the columns to a torque of 28 Kgm (280 Nm).

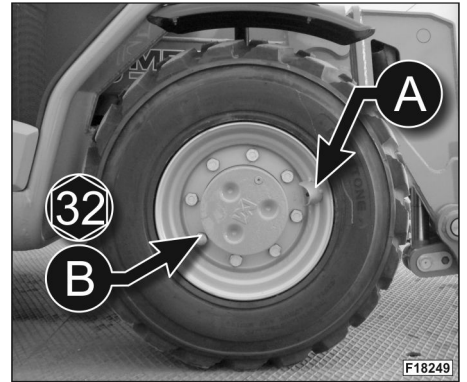

• SCHEDULED MAINTENANCE AFTER THE FIRST 50 HOURS

NUTS AND BOLTS OF THE STEERING COMPONENTS

FRONT BRIDGE (A)

Tighten to torque 30 kgm (220 lbft / 295 Nm) screws "A1" fastening the jack to the bridge (4 screws).

REAR BRIDGE (P)

Tighten to torque screws "P1" fastening the jack to the bridge (4 screws).

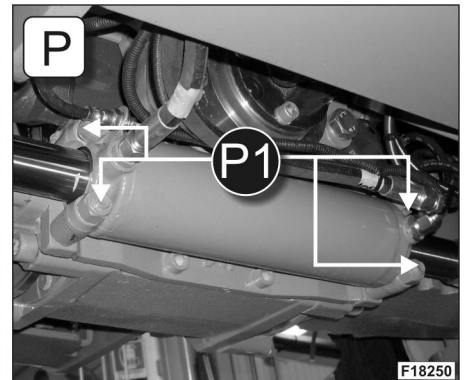
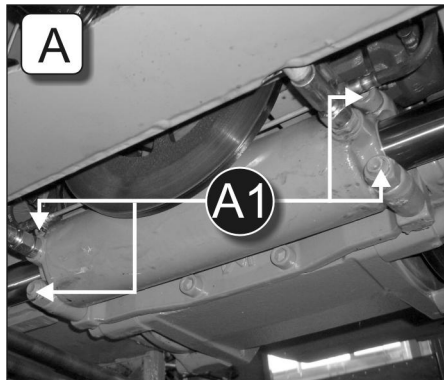

NUTS AND BOLTS FASTENING THE BRIDGES TO THE FRAME

FRONT BRIDGE (A)

Tighten to a torque of 45 Kgm (440 Nm) (325 lbft) the 8 "V2" screws which fasten the front bridge to the frame.

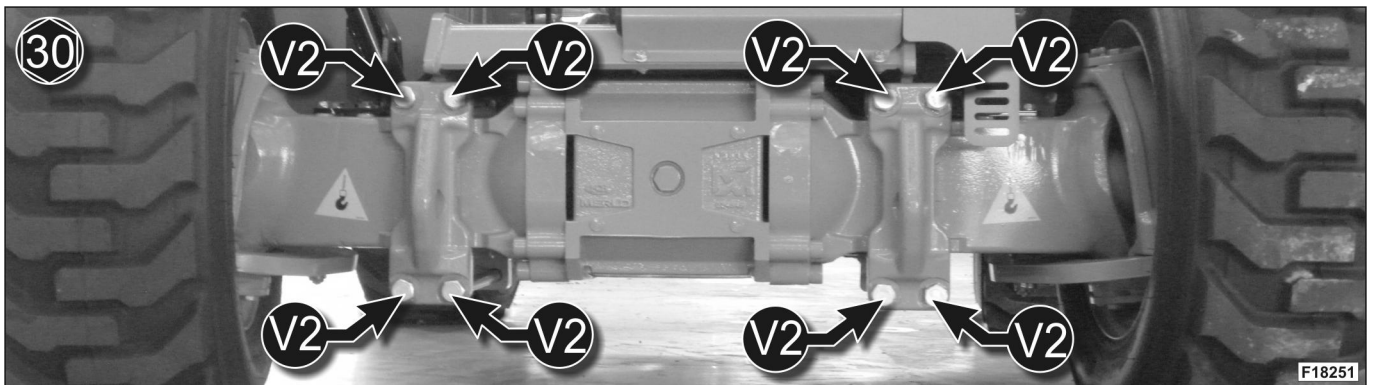



REAR BRIDGE (P)

Tighten to a torque of 45 Kgm (440 Nm) (325 lbf^t) the 6 "V2" screws which fasten the rear bridge to the frame.

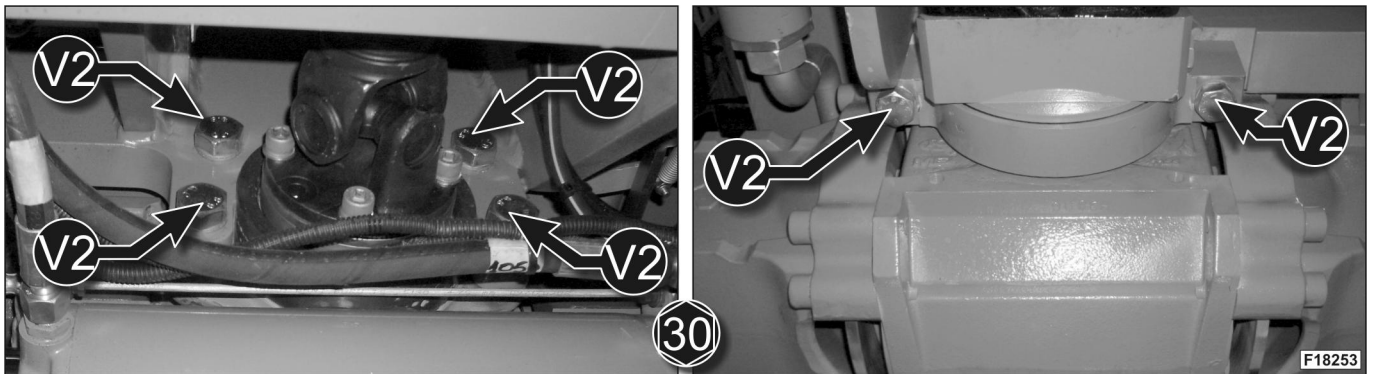

To better understand the position of the "V2" screws which fasten the front (A) and rear (P) bridge to the frame, refer to the drawing below:

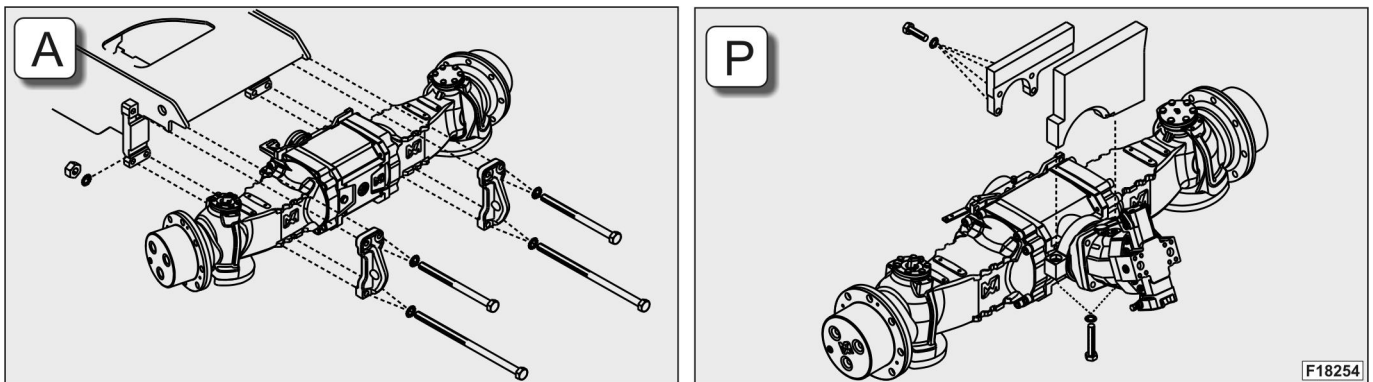

• SCHEDULED MAINTENANCE AFTER THE FIRST 100 HOURS

CARDAN JOINTS

Grease the front (F) and rear (R) cardan joints at the indicated points:

- A – grooved profiles
- B - crossings

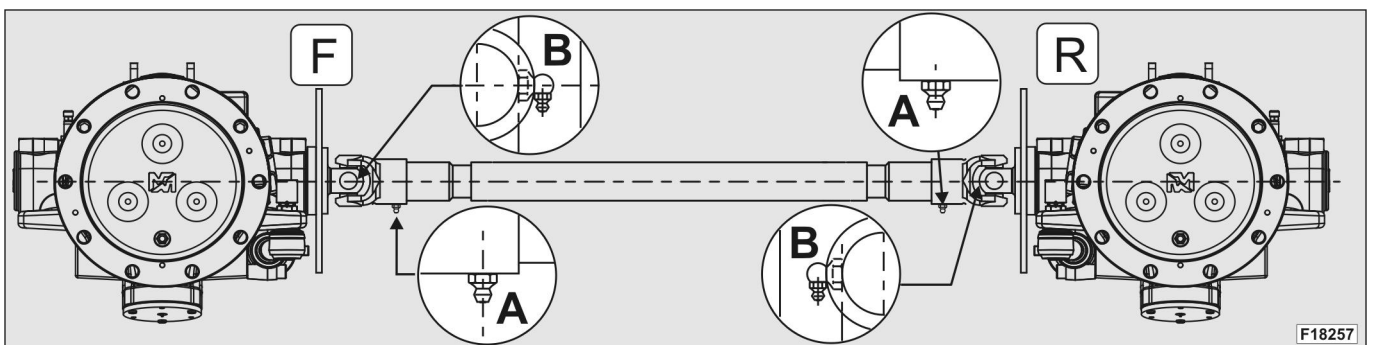

HYDROSTATIC TRANSMISSION OIL FILTER

For information on the hydrostatic transmission oil filter replacement, refer to the specific paragraph "EVERY 500 HOURS".

HYDRAULIC OIL RETURN FILTER

For information on the hydraulic oil return filter oil filter replacement, refer to the specific paragraph "EVERY 500 HOURS".



COVERS

Before carrying out some routine maintenance operations on your machine, you are required to either remove or open the following covers:

- COVER 1

Inside COVER 1, which is placed next to the fuel tank, there are some components of the front differential, of the front Cardan joint, and of the braking system. To remove COVER 1, use a proper spanner to unscrew the 3 screws shown in the picture.

- COVER 2

Inside COVER 2, which is placed on the side of the driver's cab (towards the middle of the machine), there are the hoses and fittings of the hydraulic system. To remove COVER 2, use a proper spanner to unscrew the 8 screws shown in the picture.

- COVER 3

Inside COVER 3, which is placed in the rear right mudguard of the machine, there are some components of the hydrostatic pump. To remove COVER 3, use a proper spanner to unscrew the 4 screws shown in the picture.

- COVER 4

Inside COVER 4, which is placed in the rear part of the machine, there are the components of the telescopic boom (sliding pads, extension cylinder lock valve, etc.). To remove COVER 4, use a proper spanner to unscrew the 4 screws shown in the picture.

- COVER 5

Inside COVER 5 (engine bonnet) there is the diesel engine of the machine, with all its components (filters, cups, radiator, battery, intake pipes, pumps, etc.). Proceed as follows to open COVER 5:

- use key "S" supplied to unlock the engine bonnet
- pull lever "L" towards yourself
- lift the bonnet completely until it automatically stays open

The bonnet is held open by a gas strut placed inside the engine compartment.

Proceed as follows to close COVER 5:

- lower the bonnet completely
- push lever "L" towards the machine
- use key "S" supplied to lock the engine bonnet



NEVER open the bonnet while the engine is running.



To avoid the engine bonnet opening and to prevent moving or hot parts from accidentally coming into contact with non-authorized personnel, the security keylock on the engine bonnet must be locked.



Keep the "S" key together with the engine ignition key (8).

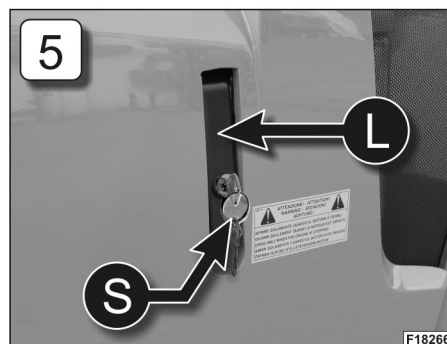
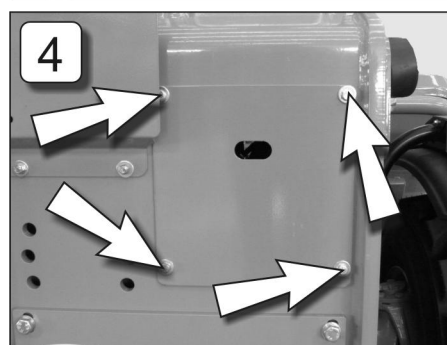
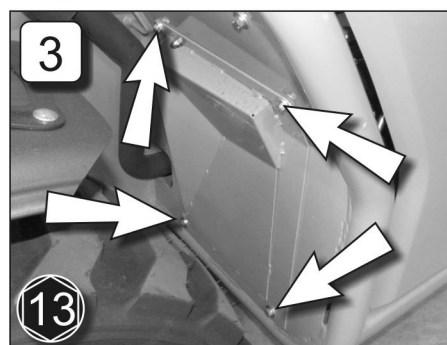
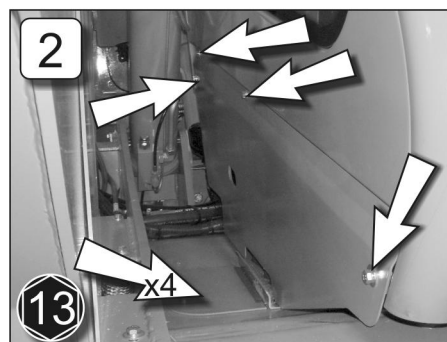
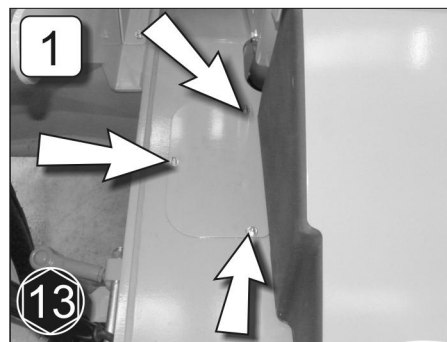

F18266



- COVER 6

Inside COVER 6, which is placed behind the driver's cab, there are the return filter and the filling cap of the hydraulic system. To remove COVER 6, use a proper spanner to unscrew the 3 screws shown in the picture.

- COVER 7

Inside COVER 7, which is placed behind the driver's seat, there is the electrical box where the fuses, the relays and the electronic boards of the machine can be found.

Proceed as follows to open COVER 7:

- unscrew fixing screws "V"
- remove COVER 7

Proceed as follows to close COVER 7:

- rest COVER 7 on the two lower supports of the electrical box
- tighten fixing screws "V"

- COVER 8

Inside COVER 8, which is placed in the rear part of the machine, there are both the hydrostatic motor and the oil filling/oil level check plug of the rear differential.

To open COVER 8, unscrew 4 fixing screws "A".

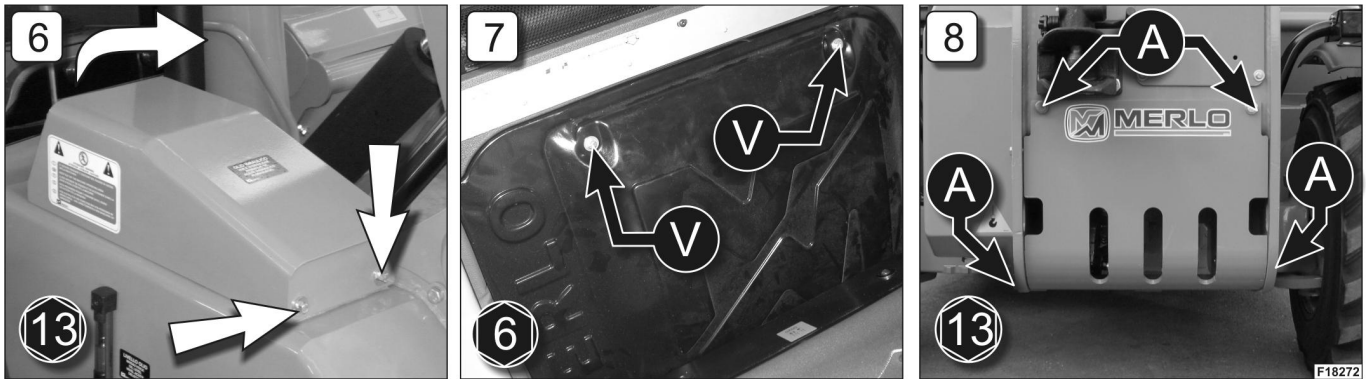

NOMENCLATURE - ENGINE COMPARTMENT

Pay particular attention to the position of the engine compartment components mentioned in this paragraph, as they will be referred to and described in the paragraphs devoted to MAINTENANCE.

NOMENCLATURE

- 1) Diesel engine
- 2) Hydrostatic transmission oil level cup
- 3) Engine coolant level cup
- 4) Engine air intake filter
- 5) Engine air intake pipe
- 6) Hydrostatic transmission oil filter
- 7) Hydrostatic pump
- 8) Diesel oil filter
- 9) Engine oil dipstick
- 10) Engine oil filler cap
- 11) Oil/ water radiator
- 12) Battery
- 13) Manual battery cut-off switch

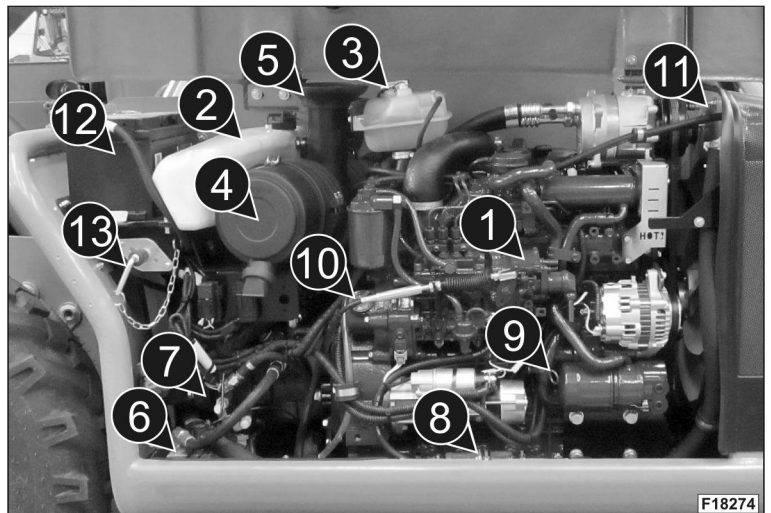



GREASING POINTS ON YOUR MACHINE

This paragraph shows all the greasing points on your machine that feature a greasing nipple. Some of these points (marked with symbol *) are described in the planned maintenance schedule, because they require more detailed explanations. For the kind of grease to be used, please refer to paragraph "FUELS AND LUBRICANTS" in this chapter.

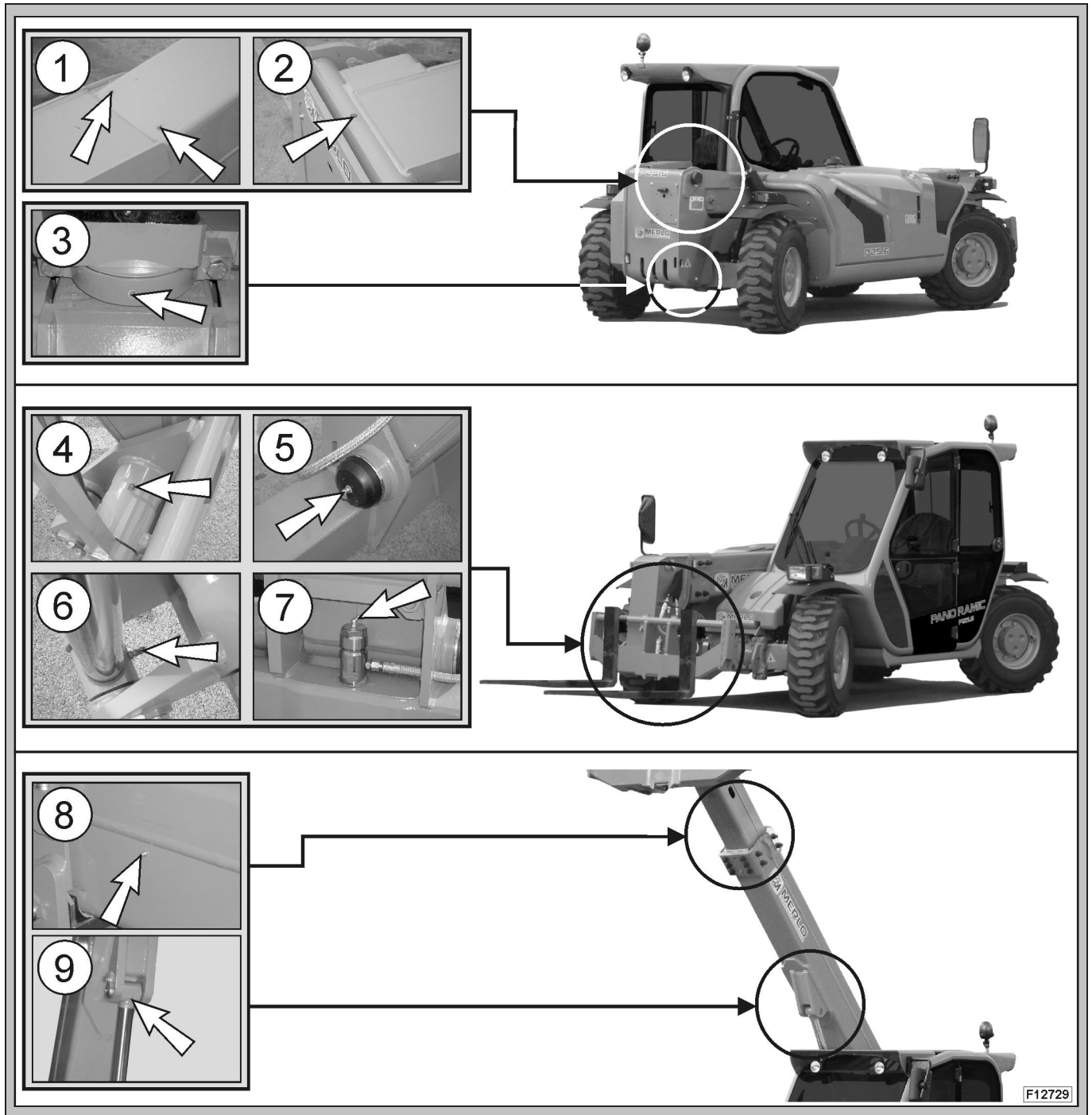

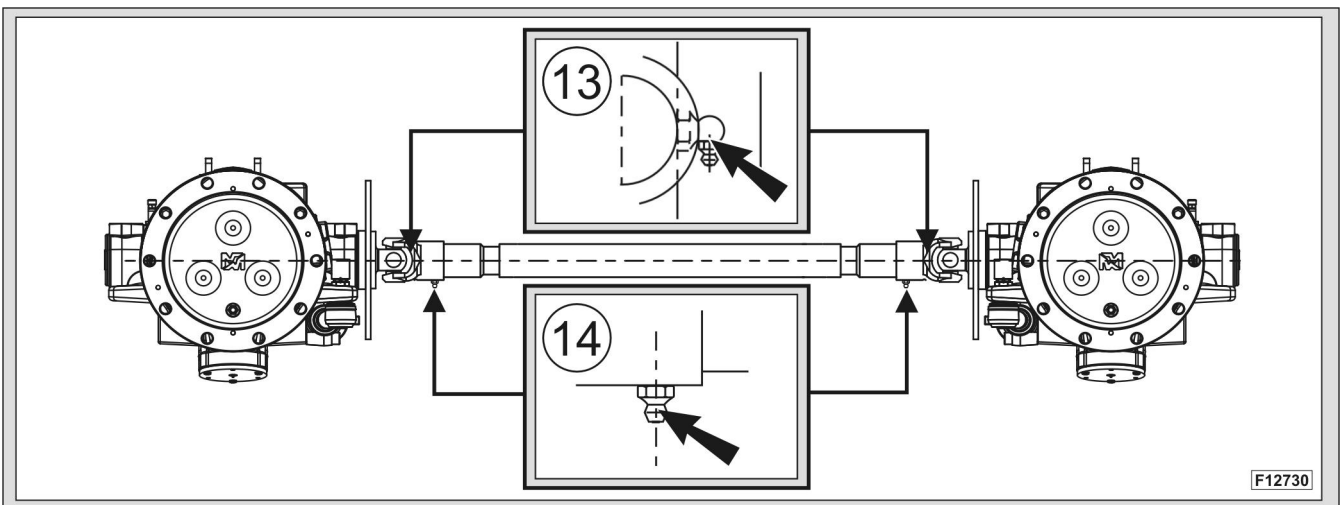
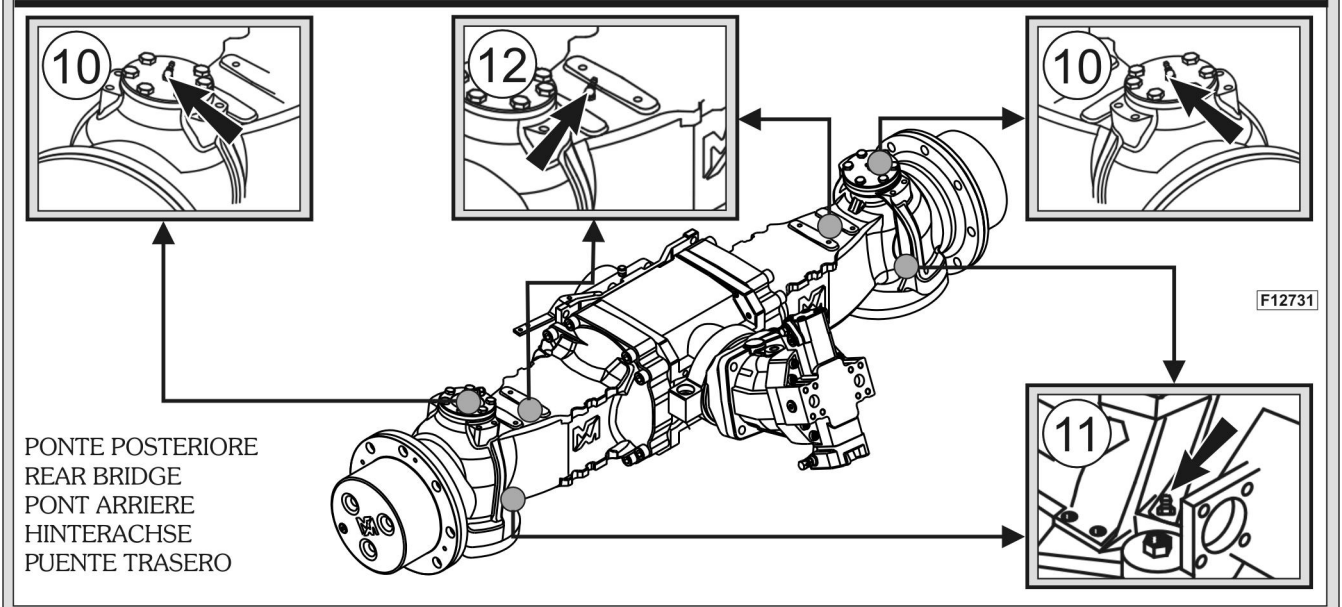
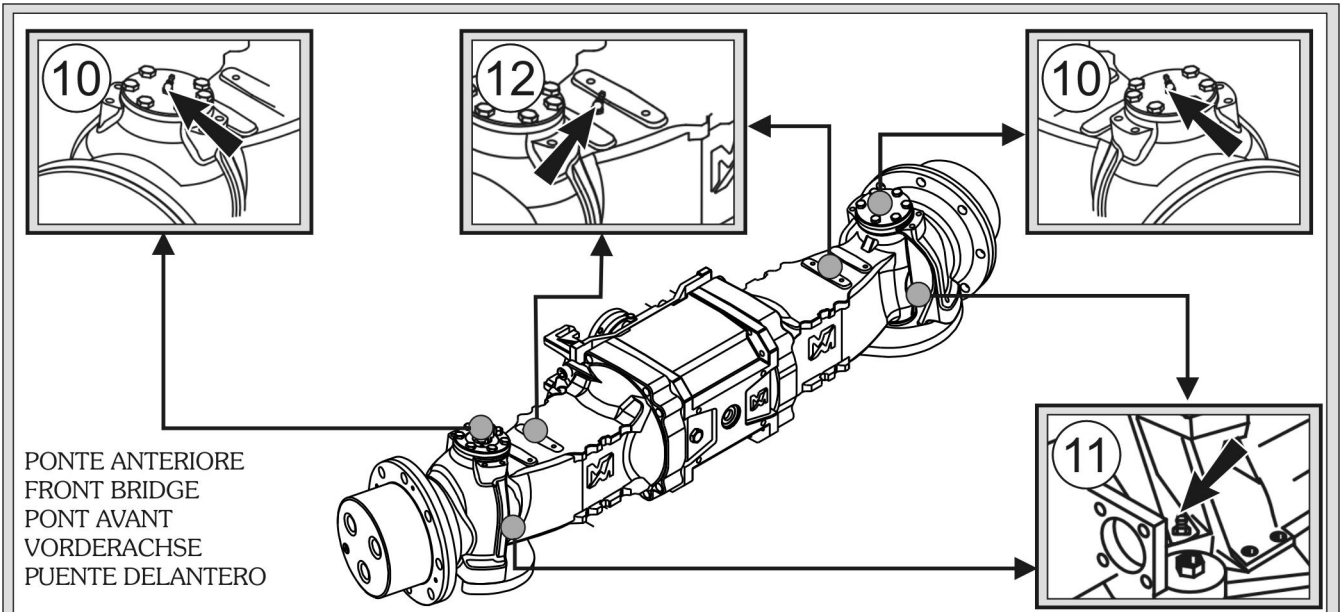



PART	GREASING INTERVALS	DESCRIPTION
1	Every 50 hours *	Grease the (inner) sliding pads of the telescopic boom
2	Every 1000 hours	Grease the telescopic boom pivot
3	Every 1000 hours	Grease the oscillating articulation joint of the rear axle
4 - 5	Every 1000 hours	Grease the carriage coupling
6	Every 1000 hours	Grease the carriage rotation cylinder
7	Every 50 hours *	Grease the hydraulic piston for attachment quick release
8	Every 1000 hours *	Grease the guide conduit of the hoses inside the telescopic boom
9	Every 1000 hours	Grease the articulated joint of the telescopic boom lift cylinder
10 - 11	Every 50 hours *	Grease the coupling of the wheel reduction hub
12	Every 50 hours *	Grease the axle shaft support bearings
13	Every 500 hours *	Grease the Cardan joint spiders
14	Every 500 hours *	Grease the grooved profiles of the Cardan joints

* These operations are described in the paragraphs devoted to periodic maintenance

MERLO PERIODIC MAINTENANCE PROGRAMME

This paragraph gives the periodic maintenance schedule that must be carried out on the machine, scrupulously respecting the established intervals. In the event of use in particularly harsh conditions, maintenance must be carried out at shorter intervals. The machine maintenance schedule is based on:

- working time bands (every 10 hours, 50 hours, 500 hours, 1000 hours, 1500 hours)
- working periods (daily, weekly, every 6 months, every 12 months, every 18 months)

The time bands and periodic intervals are combined as follows:

- 1) EVERY 10 HOURS OR DAILY
- 2) EVERY 50 HOURS OR WEEKLY
- 3) EVERY 500 HOURS OR 6 MONTHS
- 4) EVERY 1000 HOURS OR 12 MONTHS
- 5) EVERY 1500 HOURS OR 18 MONTHS

The operator must perform routine machine maintenance considering which of the 2 situations (hourly or periodic) occurs first. All the maintenance operations must be performed cyclically. At each maintenance interval, perform also the operations described in the previous intervals: for example every 1000 hours perform also the maintenance contemplated at 500, 50 and 10 hours. The 5 scheduled maintenance intervals, summed up in the following table, will then be analysed individually in the subsequent paragraphs.



CAUTION!

- **Maintenance of your machine must be performed by qualified and competent personnel.**
- **To perform maintenance operations correctly, position the machine on a flat, solid surface.**
- **Before performing maintenance make sure that the diesel engine is turned off and that the battery cut-off switch (if present) is in OFF position**
- **To know which oils and greases to use for machine maintenance, refer to the paragraph "FUELS AND LUBRICANTS" in this chapter and to the OILS TABLE in the chapter "CONTROL STICKERS - LEAFLETS IN CAB". The grease nipples not mentioned in the maintenance table are to be greased periodically every 1000 HOURS or 12 MONTHS depending on the actual conditions of use of the machine.**
- **Always use original spare parts approved by Merlo S.p.a.**
- **To know the times and the maintenance jobs to be done on the diesel engine, always refer to the engine manual supplied with the machine.**
- **It is advisable to make a note of the date when maintenance is carried out so as to perform the operations regularly.**



PERIODIC MAINTENANCE SCHEDULE		
ITEM	* EVERY 10 HOURS	DESCRIPTION
Hydraulic oil		Check level and top up
Hydrostatic transmission oil		Check level and top up
Engine cooling system		Check level and top up
Tyres and wheel bolts		Inspect
Safety belts		Inspect
ITEM	* EVERY 50 HOURS	DESCRIPTION
Boom sliding pads (Internal)		Grease until it escapes around seal
Reduction hub articulation		Greaser
Brakes pads		Check wear
Tires and stud bolts		Check pressure and stud bolts tightening
Air ventilation filter		Clean
Air intake hoses		Check connections
Battery		Check electrolyte level and terminals
Air cleaner		Clean
Brake oil		Check level
Sliding pads of the telescopic boom (outer pads)		Check
Plunger for quick uncoupling of attachments		Greaser
Axle shaft bearings		Grease
ITEM	EVERY 500 HOURS	DESCRIPTION
Hydraulic sump bleed filter		Replace
Reduction hub oil		Check level
Differential oil		Check level
Cap screws and bolts		Check tighten
Universal joints		Grease
Fuel tank		Drain water and sediments
Hydrostatic transmission oil filter		Replace
Hydraulic oil filter on return line		Replace
Air cleaner		Replace
Sliding pads of the telescopic boom (inner pads)		Check
Pipes-guide pipe		Grease
Fuel filter		Check
ITEM	EVERY 1000 HOURS	DESCRIPTION
Articulated joints		Check the slacks and grease
Boom sliding pads (External)		Grease until it escapes around seal
Anti-dust filter		Replace
Hydraulic pipes/hoses		Inspect
ITEM	EVERY 1500 HOURS	DESCRIPTION
Hydrostatic transmission oil		Replace
Hydraulic oil		Replace
Differential oil		Replace
Reduction hub oil		Replace
Brake fluid		Replace



DAILY OR EVERY 10 HOURS

• HYDRAULIC OIL

To check the hydraulic oil level it is necessary to:

- place the machine on a perfectly even ground
- lower and retract the telescopic boom completely
- switch off the Diesel engine
- check indicator "A" to ensure that the hydraulic oil level reaches up to about 5 mm from the upper edge of the inspection window
- if necessary, remove COVER 6 (see paragraph "COVERS" in this chapter), remove the filler cap (B), and fill up oil (see also "OIL TABLE" in chapter "STICKERS WITH CONTROL DESCRIPTIONS - LEAFLETS IN THE CABIN")



NOTE! To ensure the machine's optimum performance, regularly check oil level in the hydraulic system, and top up oil if necessary.

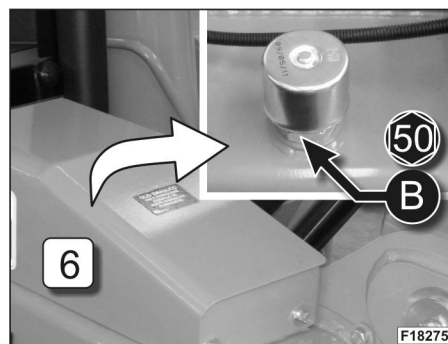
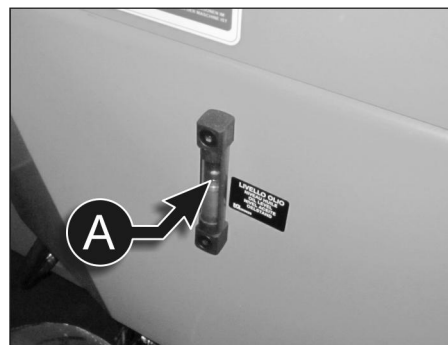

• HYDROSTATIC TRANSMISSION OIL

Check the level of the hydrostatic transmission oil present in plastic tank "A".



WARNING! Do not remove cap "B" unless engine is cold. Then turn the cap slowly to its stop. Release all pressure before you fully remove cap.

The hydrostatic oil level must be visible within the glass "C", that is close to the filling cap.

If the level is low, top up specific oil (see also "OIL TABLE" in chapter "STICKERS WITH CONTROL DESCRIPTIONS - LEAFLETS IN THE CABIN").

Put in place and tighten cap "B" and check for any leak in the system.

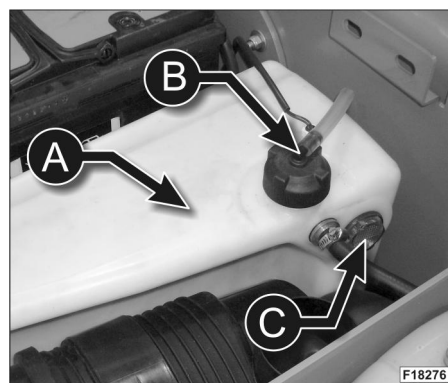

• COOLING SYSTEM

Check the engine coolant level.



WARNING !! Do not remove cap "B" unless engine is cold. Then turn the cap slowly to stop. Release all pressure before you remove cap. For further informations, refer to the relative engine workshop manual.

The level of the coolant, present in the expansion tank "A", shall be included in the range "MIN" ÷ "MAX" shown on the label. If the engine coolant level is low, top up with a coolant available on the market. Tighten the filler cap and check the cooling system for loose connections and leaks.

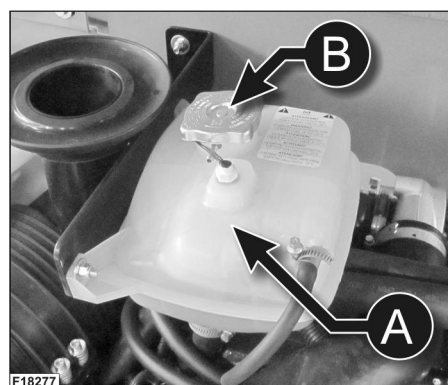

• TIRES AND STUDS BOLTS

Check that wheel studs are tighten and tires are properly inflated. Daily inspect tires for damages or excessive wear.



• SAFETY BELTS

Check the presence, function and the good condition of safety belt "A".



IMPORTANT!

Do not use the machine on site if the safety belt is not in efficient working condition.



EVERY 50 HOURS OR WEEKLY

• TELESCOPIC BOOM SLIDING PADS (INTERNAL)

To guarantee optimal performance of the telescopic boom, it is necessary to grease the internal sliding shoes. To properly carry out this operation, proceed as follows:

- Fully retract the telescopic boom
- Generously apply the specific product for the boom (internal) sliding shoes through greasers "A" (see paragraph "FUELS AND LUBRICANTS")
- Execute a few boom extraction and retraction cycles, so as to evenly distribute the grease inside the shoes.

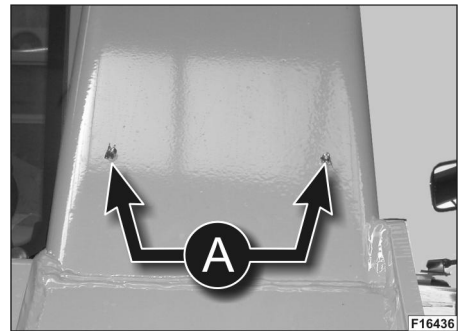

• REDUCTION HUB ARTICULATION

To ensure optimal performance of the wheel reducers, it is necessary to grease them as follows:

- Stop the machine
- Apply some specific grease for the reducer joints through greasers "A" and "B" until it comes out (see chapter "FUELS AND LUBRICANTS")
- Repeat the operations for all wheel joints
- Carry out a few complete steering cycles to evenly distribute the grease inside the reducers.



NOTE! To facilitate the reducer greasing operations, it is possible to steer the wheels to have a larger view of greasers "A" and "B".

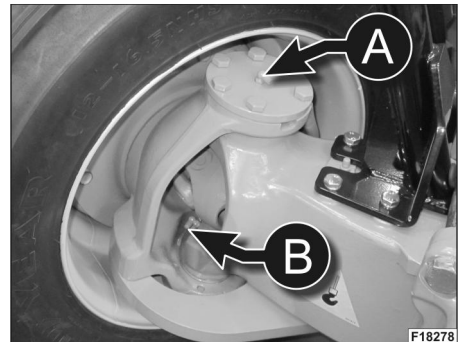

• BRAKE PADS

Check the wear of brake pads as follows:

- Stop the diesel engine
- Lie under the machine until you reach the area where brake calipers are located
- Check pads "A" on both sides of the bridge
- Repeat the operation for the other bridge

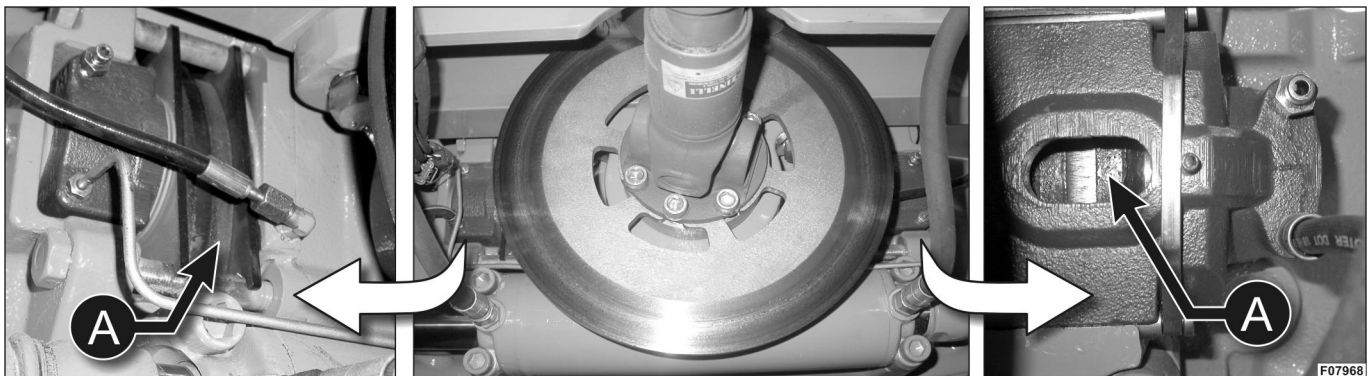



If the detected friction material thickness is less than 2 mm (1/12 in), pads must be replaced .



WARNING! *The maintenance and replacement of brake pads must be carried out by skilled and competent personnel. Contact Merlo Technical Support Service.*

• TYRES AND WHEEL STUDS

Check tyre pressures with an accurate gauge, "A" = inflating valve.
Check studs (B), tighten to 28 Kgm (280 Nm).



WARNING !

The tyres which can be used on the machine are those indicated in the Merlo List and/or in the machine registration document (if provided).

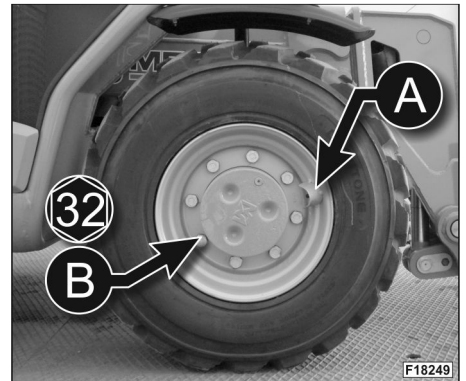

• CAB VENTILATION SYSTEM FILTER

To check its cartridge, follow the instructions below:

- Unscrew fastening screws "V"
- Extract the cab ventilation filter
- Clean the filter using a jet of compressed air
- Check the filter wear condition and, if needed, replace it with a new filter with the same features

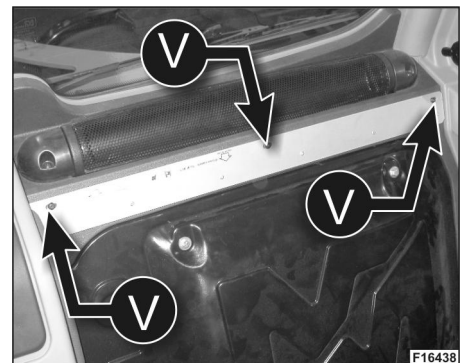

• AIR INTAKE HOSES

Tighten all hose clamps (A) and check conditions of hoses and ducting.

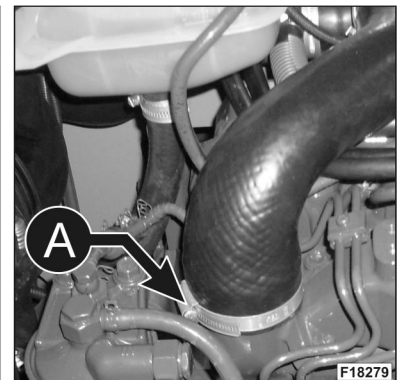
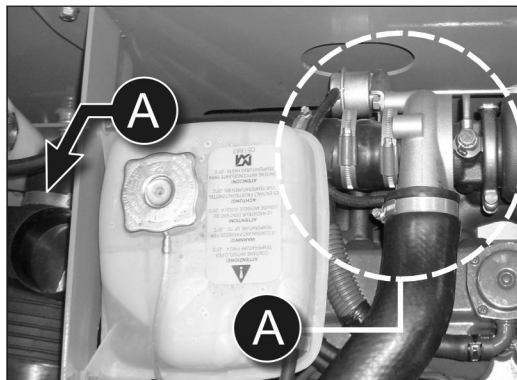



• BATTERY



WARNING ! Read carefully the instructions in the chapter "ELECTRIC SYSTEM" before carrying out any intervention on the battery. Keep battery and its compartment clean and terminals covered with vaselin grease to avoid corrosion.

Disconnect negative (-) terminal cable before you charge battery or act on electrical system.

Check the electrolyte level and terminal + and -. Wipe battery with damp cloth. Clean terminals with stiff brush. If necessary wash battery with baking soda solution: 0,1 Kg (3.3 oz). added to 1 lt (1 quart) of water.

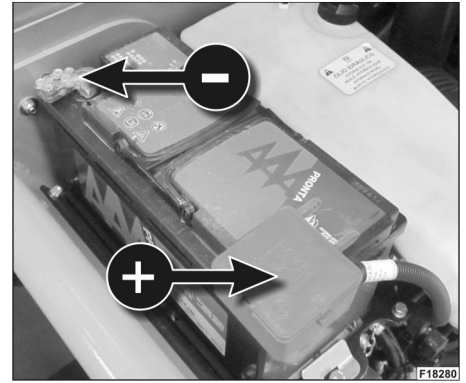

• AIR CLEANER

- A) cover
- B) filter cartridge
- C) safety cartridge
- D) filter body
- E) wing screw
- F) wing nut

Check if the cartridge is clean:

- if the clog warning lamp (47) lights
- if the motor smoke is over the limit
- if the motor loses power

OPERATING INSTRUCTIONS

- Open the filter by removing the wing screw "E"
- Extract the filter cartridge "B" from its seat by removing the wing nut "F".

The filter cartridge "B" can be cleaned by following the instructions here below:

- turn a jet of compressed air not over 5 bar (72 psi) from the inner side to the outer side of the cartridge;
- tap the cartridge against your palm (makeshift solution), taking care not to damage it;
- clean the cartridge by washing it in a special solution (this operation is allowed but not recommended)



WARNING! It is strictly forbidden to use petrol or warm fluids to clean the filter cartridge.

- Insert a lamp inside the cartridge and hold it up to the light to check the condition of the filtering paper and of its gaskets.
- Check that there are no rips or holes, even little, and if so, replace the cartridge. This one shall be also replaced:
 - if it is damaged
 - after one year of active service
 - if it cannot be cleaned
- Before installing the cartridge again, clean inside the filter body (D) and the cover (A).

**NOTE!**

The safety cartridge "C" doesn't need to be cleaned.

**WARNING!**

In case of use of the machine in particularly dusty environments, it is necessary to install the special pre-filtering devices.

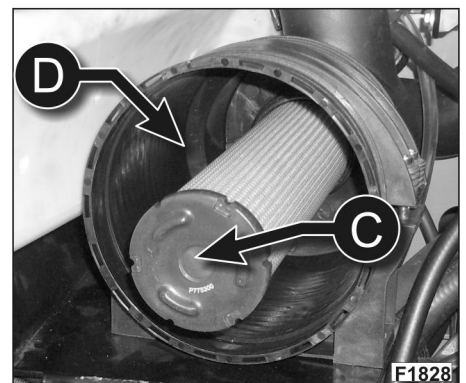
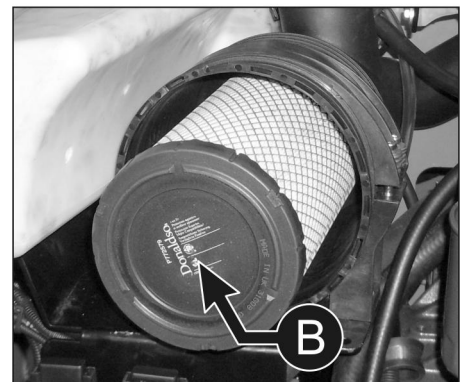
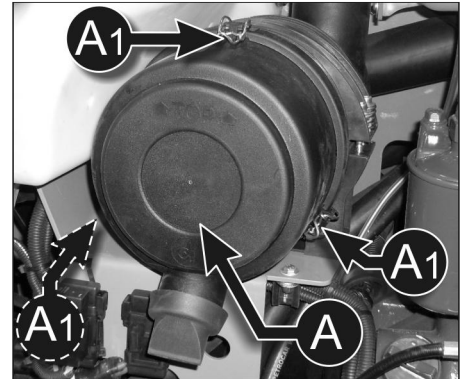



• BRAKE FLUID

To check the brake oil level:

- Place the machine on a perfectly levelled surface
- Stop the diesel engine
- Remove housing "A"
- Remove cap "B" from the control tank.

The oil level must be about 3.5 cm (1 3/8 in) from the upper brim of the tank. A slight decrease in the level is due to the normal wear of brake pads.

Such level shall never be less than the minimum "MIN"; if needed, fill up to the indicated level, without going over the maximum level ("MAX"). For information on the type of brake oil to use, refer to paragraph "OIL TABLE" in chapter "STICKERS WITH CONTROL DESCRIPTIONS - LEAFLETS IN THE CABIN".

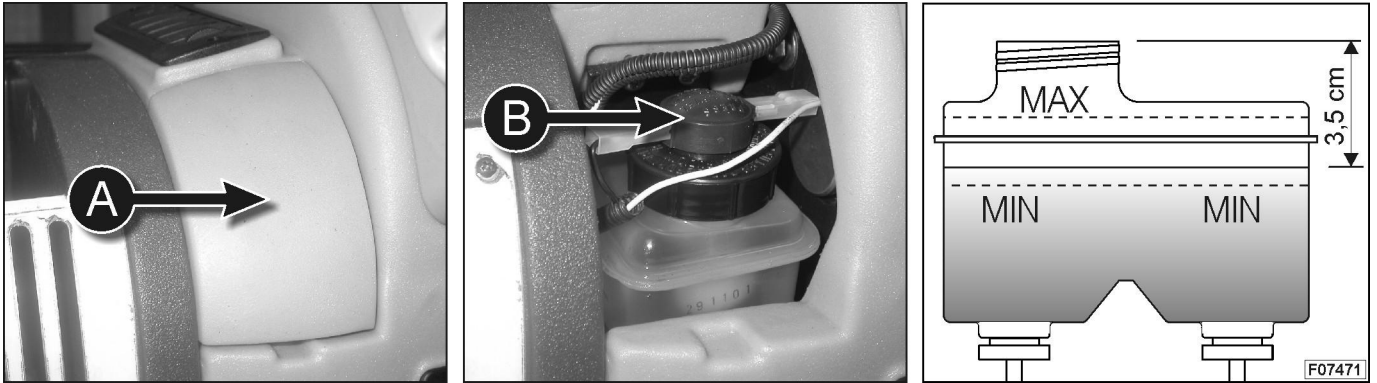

WARNING ! Significant lowering of fluid level is due to system leakages. Ask for skilled personnel to check it. Be careful when filling up the appropriate tank with brake oil, as the liquid is particularly toxic and could ruin painted or plastic surfaces.

• SLIDING PADS OF THE TELESCOPIC BOOM (OUTER PADS)

Perform the following checks on all the outer sliding pads of each boom:

- 1 - visual inspection of outer sliding pads to check for wear
- 2 - visual inspection of outer sliding pads to check for wear uniformity
- 3 - visual inspection of the boom surface to check for any indentations due to the sliding of outer sliding pads
- 4 - visual inspection of outer sliding pads to check for any burr or large shavings (plastic powder is accepted)

Should either condition "1" or "2" be met, please contact Merlo Technical Support Service.

Should either condition "3" or "4" be met, please proceed as follows:

- remove grease from the telescopic boom surface
- adjust the telescopic boom as described in the paragraph "GENERAL MAINTENANCE"
- apply a layer of boom-specific grease by Merlo, as described in paragraph "OUTER SLIDING PADS OF THE TELESCOPIC BOOM"

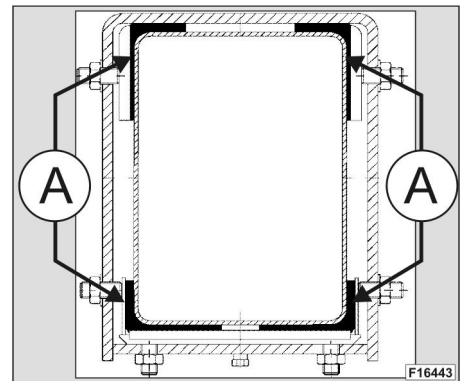

Should the problem persist, please contact Merlo Technical Support Service for a repair.



NOTE! While extending and retracting the telescopic boom, some paint might be removed from the areas where the outer pads of the telescopic boom slide. This is to be considered absolutely normal, and it does not interfere with the correct operation of the telescopic boom.



• GREASING THE PLUNGER FOR QUICK UNCOUPLING OF ATTACHMENTS

Periodically grease the plunger for quick uncoupling of attachments; grease makes it easier for plunger "A" to slide, and prevents rust from forming inside the cylinder chamber.

To perform this operation correctly, please follow the instructions below:

- lower the telescopic boom
- stop the engine
- apply 30 ml (1 fl oz) of specific grease (see paragraph "FUELS AND LUBRICANTS") with lubricator "B"
- start the engine, and perform a few plunger lifting cycles (plunger "A"). During the first cycle plunger "A" may move slowly, since the grease applied needs to flow from the plunger to the spring. This delay is more significant at low room temperature. Excess grease inside the chamber is expelled from the side of plunger "A" during the first cycle.

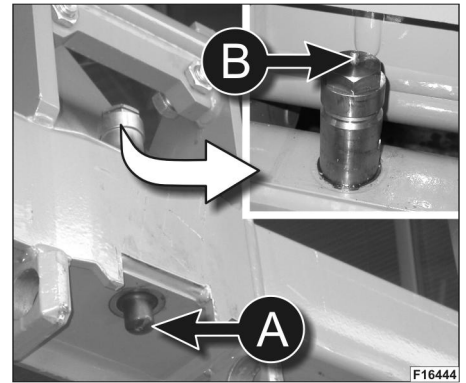

• AXLE SHAFT BEARINGS

The grease nipples of the axle shaft support bearings are located in the upper part of the two axles, and require the following maintenance:

- stop the machine
- apply 0,5 fl oz (15ml) of specific grease (see paragraph "FUELS AND LUBRICANTS") with lubricator "A"
- repeat the operation for the other axle shafts of the machine
- Perform a few forward/reverse drive cycles with steered wheels so as to evenly spread grease inside the axle shafts

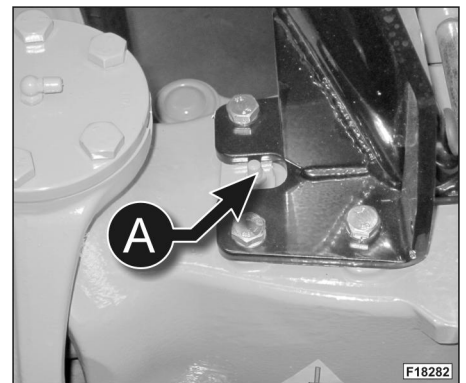

EVERY 500 HOURS OR EVERY 6 MONTHS

• HYDRAULIC SUMP BLEED FILTER

Replacement of the filter cartridge:

- Unscrew the fastening screw (1)
- Remove the cap (2)
- Remove the cartridge (3) and replace it with a new one having the same characteristics
- Reinstall the cap (2).
- Tighten the fastening screw (1)
- Check that the lower washer is in the correct position (4).

Start the machine and check for any leak in the hydraulic system.

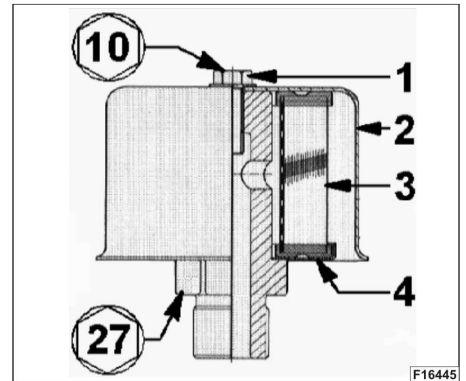

• REDUCTION HUB OIL

To check the reduction hub oil level, the machine shall be in such a position that level plug "A" is vertically aligned with the wheel centre (see picture).

- Remove plug "A" by using a proper hexagonal wrench
- Check that reduction hub oil reaches up to the hole edge.
- If necessary, top up specific oil (see "OIL TABLE" in chapter "STICKERS WITH CONTROL DESCRIPTIONS - LEAFLETS IN THE CABIN")
- Reinstall and tighten plug "A".



NOTE! Repeat the same operation for each reduction hub of the machine.

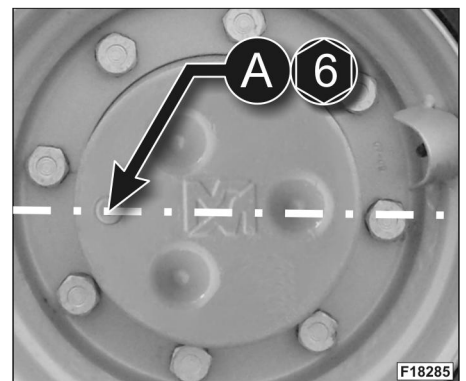



• FRONT AND REAR DIFFERENTIALS OIL

Carry out the following operations to properly check the oil of the front and rear differentials:

FRONT AXLE (3)

- Remove cap (A)
- Check that differential oil reaches up to the hole edge.
- If needed, fill up with specific oil (see the "OIL TABLE" in chapter "CONTROL STICKERS - LEAFLETS IN THE CAB")
- Reinstall caps (A) and tighten them.

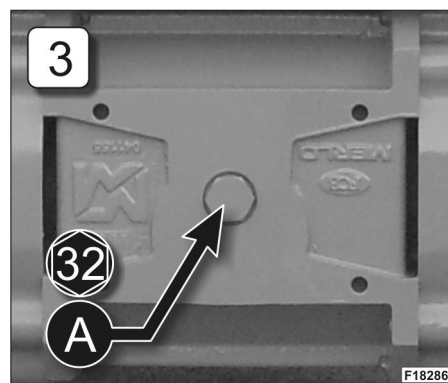

REAR AXLE (4)

- (P) = level plug
- (P1) = filling cap
- Remove caps (P) and (P1); to access the caps (P) and (P1) on rear axle, you need to remove COVER 8 first (see paragraph "COVERS" in this chapter).
- Check that the differential oil reaches the edge of the hole (P)
- If needed, fill up with specific oil from the hole (P1) (see the "OIL TABLE" in chapter "CONTROL STICKERS - LEAFLETS IN THE CAB")
- Reinstall caps (P) and (P1) and tighten them.



• CAP SCREWS AND BOLTS

Check for tightness. See torque chart in this manual (section MACHINE TECHNICAL SPECIFICATIONS). In the paragraph BREAK IN PERIOD you can find the instructions for the bolts and nuts check of some vehicle parts.



• UNIVERSAL JOINTS

Lubricate every 200 hours when used under heavy conditions.

FRONT AXLE

Universal joints between gear box and differentials :

- F Front universal joint
- R Rear universal joint

Grease points shown in picture:

- A splines
- B crosses

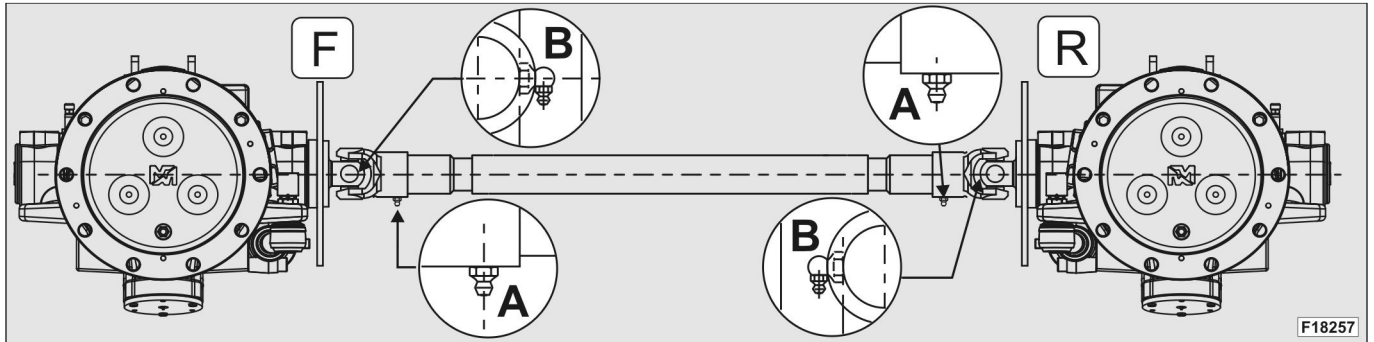

• FUEL TANK

Carry out the following operations to discharge any water or sediment from the fuel tank:

- Place an appropriately sized container underneath discharge cap "A"
- Loosen discharge cap "A" using an appropriate hexagonal wrench
- Discharge the water and sediments contained in the tank
- Tighten discharge cap "A".

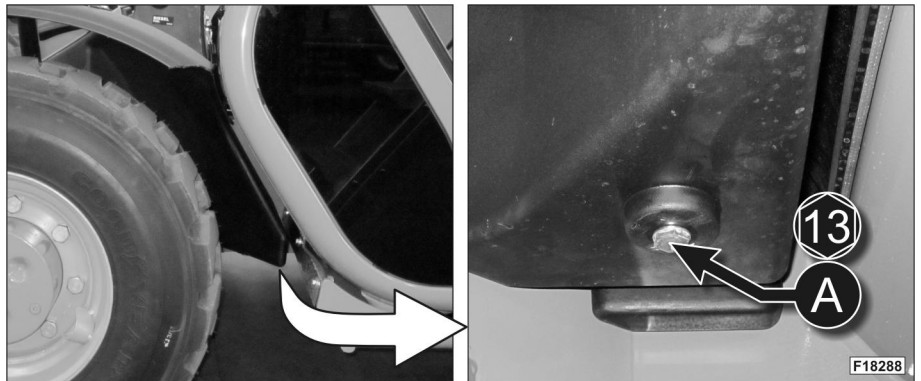

Tighten to torque 15Nm (11 lbft).

• HYDROSTATIC TRANSMISSION OIL FILTER

Replace the hydrostatic transmission filter:

- Place an appropriately sized container underneath filter "A"
- Loosen filter "A"; to carry out this operation, use an appropriate chain or ribbon extractor
- Collect the oil that flows out
- Remove filter "A"
- Fill the new filter with specific oil through the appropriate outside holes
- Fill up the oil in the tank and wait for the air to flow out.





• HYDRAULIC OIL FILTER ON RETURN LINE

Hydraulic oil return filter "A" is located in the CARTER 6

To carry out the replacement procedure, please follow the instructions below:

- unscrew the 4 screws "V" which fasten the filter cap
- remove the cap assembly and its gasket "G"
- remove filter "B" by lifting it with handle "M"
- replace filter "B"
- reinstall all components without damaging gaskets
- reinstall the filter cap by tightening the 4 fastening screws

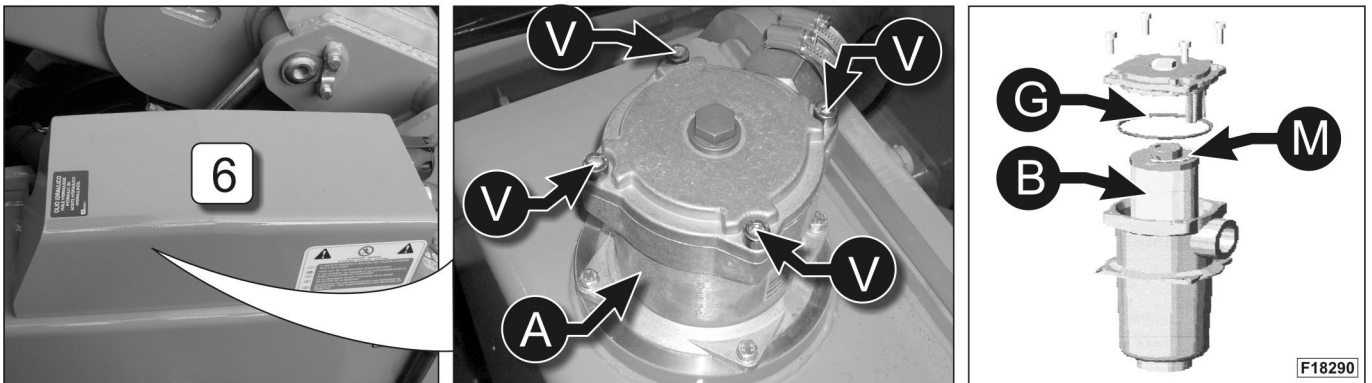

• AIR CLEANER

A) cover - B) filter cartridge - C) safety cartridge - D) filter body

Replace the filter cartridge "B" and the safety cartridge "C".

CARTRIDGE INSTALLATION

- Insert safety cartridge "C" inside filter body "D", and push it towards the inside
- Insert filter cartridge "B", and push it towards the inside of the filter body
- Close filter cover "A" with locking devices "A1"

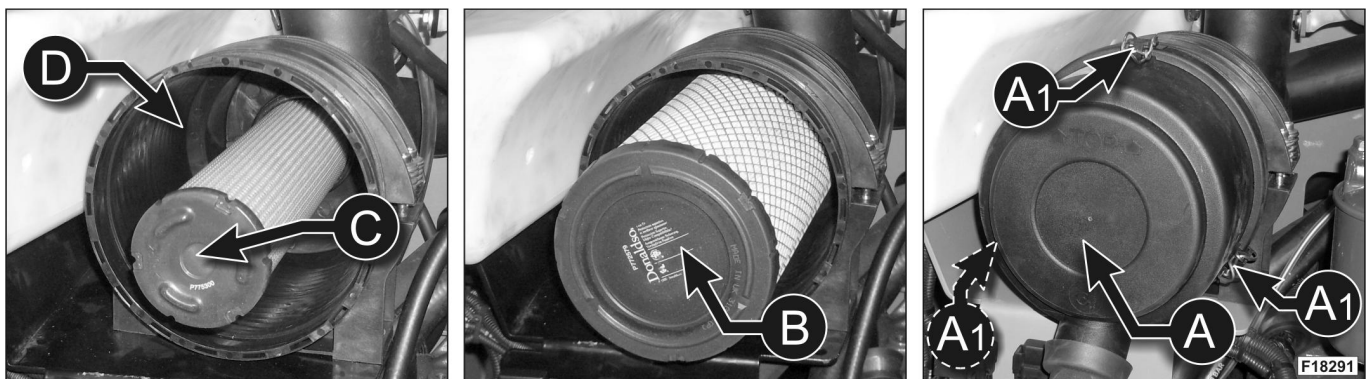



• SLIDING PADS OF THE TELESCOPIC BOOM (INNER PADS)

To ensure maximum reliability, performance and durability for the telescopic boom, it is necessary to perform a visual inspection of inner sliding pads "B".

To inspect the inner sliding pads of the telescopic boom, remove rear case "4" first (see also paragraph "COVERS").

Perform the following checks on the inner sliding pads of the telescopic boom:

- 1 - visual inspection of inner sliding pads to check for wear
- 2 - visual inspection of inner sliding pads to check for wear uniformity
- 3 - visual inspection of inner sliding pads to check for any breaks
- 4 - visual inspection of inner sliding pads to check for any burr or large shavings (plastic powder is accepted).

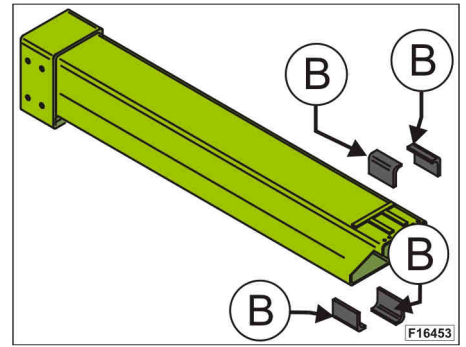

Should any of the above conditions be met, please contact Merlo Technical Support Service.

• PIPES-GUIDE PIPE

Completely extend the boom and grease (about 200 ml / 7 fl oz) in the points shown (A).

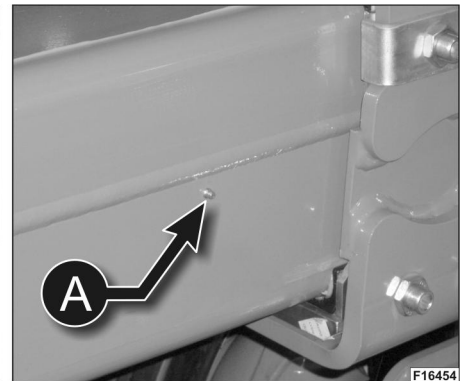
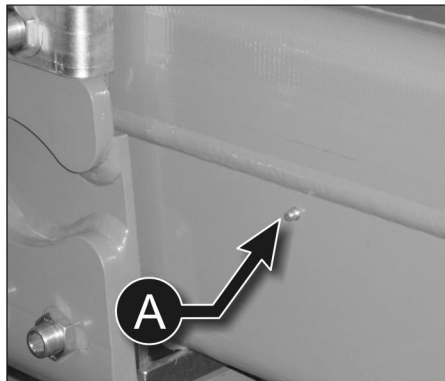

• DIESEL FILTER

Check if the diesel filter "A" is obstructed by proceeding as follows:

- Stop the machine engine
- Lie under the engine (in the area towards the centre of the frame) and inspect the diesel filter "A" through one of the holes on the enclosure (see picture)

If the diesel filter is excessively dirty, clean it by the proceeding as follows:

- Remove the engine lower protection enclosure
- Remove the diesel filter fastening bands "B" and disconnet the diesel filter from the conduits
- Direct an air blast in the opposite direction to the fuel flow, so as to eject any sediments the filter may contain
- Inspect the inside of the filter and make sure that the net is in good conditions and contains no cloggings. Otherwise, request a spare net to the Merlo Technical Support Service and replace the old net.
- Mount back the filter by connecting the conduits and inserting the fastening bands "B".

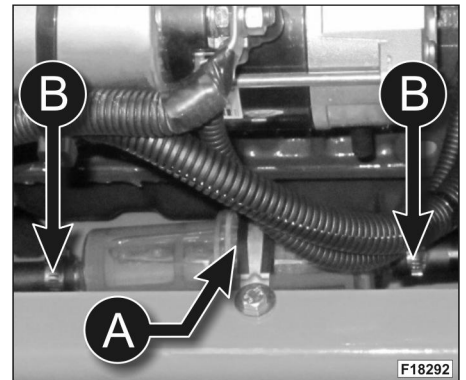

WARNING! The diesel filter has a printed arrow on its plastic shell which indicates the fuel flow direction. When mounting back the filter onto the engine, make sure it is inserted in the correct direction, otherwise it will lose its protective efficiency.



EVERY 1000 HOURS OR EVERY 12 MONTHS

• ARTICULATED JOINTS

Check the existing play on the articulated joints of the indicated components. If the play is more than 1 mm, replace the related bushings.

Lubricate the articulated joints of the indicated components which do not have a greaser.

A) Wheel reducers - B) Front bridge - C) Rear bridge - D) Boom - E) Carriage - F) Fork jack

G) Lifting jack - H) Compensation jack



WARNING!

If you need to use your machine in particularly difficult situations (dusty or muddy environments, etc.), or if you use your machine every day in a continuous way for several hours a day, you need to grease the parts shown in the table either EVERY 50 HOURS or WEEKLY.

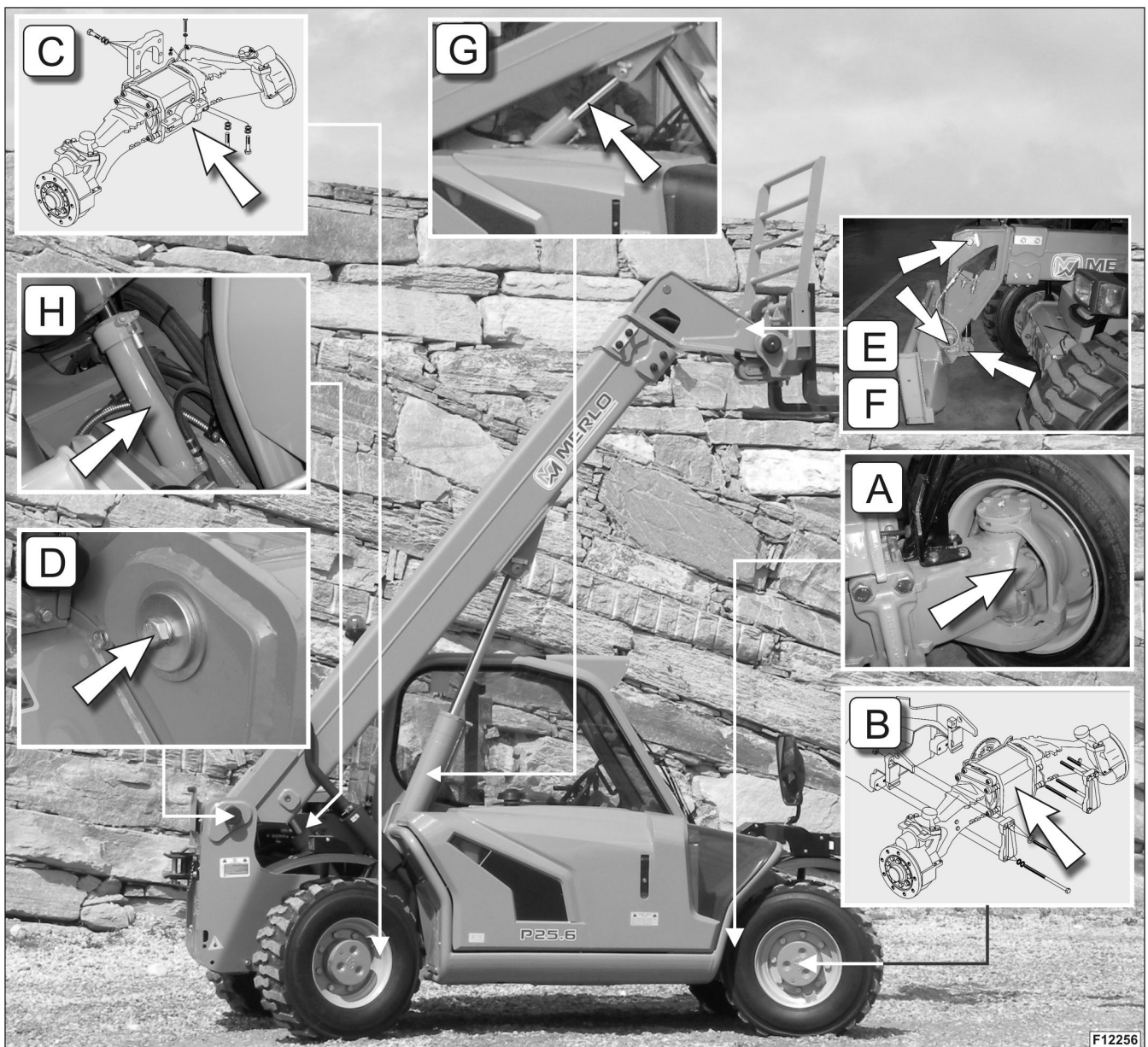

F12256



• BOOM SLIDING PADS (EXTERNAL)

- Fully extract the telescopic boom
- Carefully clean the boom sliding surface, taking away the residual grease
- With the help of a cotton wad, evenly spread a thin layer of grease (see chapter "FUELS AND LUBRICANTS) on the entire boom sliding surface
- Carry out a few boom extraction and retraction cycles, so as to evenly distribute the product.

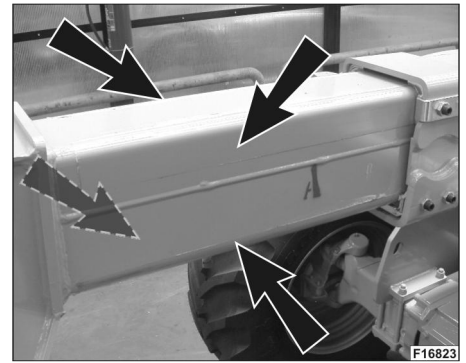

WARNING!

It is possible to use only the recommended product; a different product could cause serious damages to the sliding surface of the boom. When using the machine in particularly demanding conditions it is necessary to grease more frequently.

• AIR VENTILATION FILTER

Replace the cab ventilation system filter as follows:

- Unscrew fastening screws "V"
- Extract the cab ventilation filter
- Replace the filter with a new one with the same features
- Mount back the filter tightening fastening screws "V".

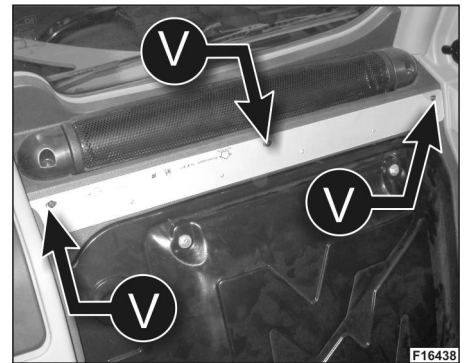

• HYDRAULIC PIPES/HOSES

Perform the following checks on the hydraulic pipes/hoses:

- 1) visual check for any oil leakage
- 2) visual check for any marks on the hydraulic pipes/hoses which might be indicative of future oil leakage (picture 1)
- 3) visual check for any mechanical scraping or graze on the external protection of the hydraulic pipes/hoses (picture 2)

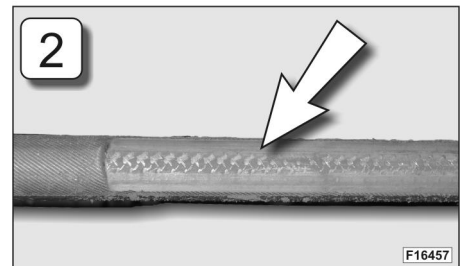
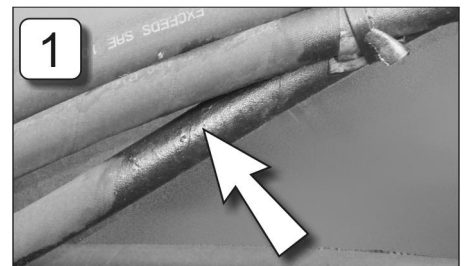

Should any of the conditions above be met, replace the faulty pipe/hose as soon as possible, so as to prevent the problem from getting worse.



NOTE! Pictures 1 and 2 show some examples of problems which might occur on hydraulic pipes/hoses.



EVERY 1500 HOURS

• HYDROSTATIC TRANSMISSION OIL

To properly carry out the hydrostatic transmission oil replacement, follow the instructions below:

- 1) Radiator
- 2) Tank
- 3) Hydrostatic pump
- 4) Fuel electro-pump
- 5) Hydrostatic transmission filter
- 6) Hand pump

The overall system capacity is 12 l.



WARNING! Only use the hydrostatic oil shown in the OIL TABLE of chapter STICKERS WITH CONTROL DESCRIPTIONS - LEAFLETS IN THE CABIN.

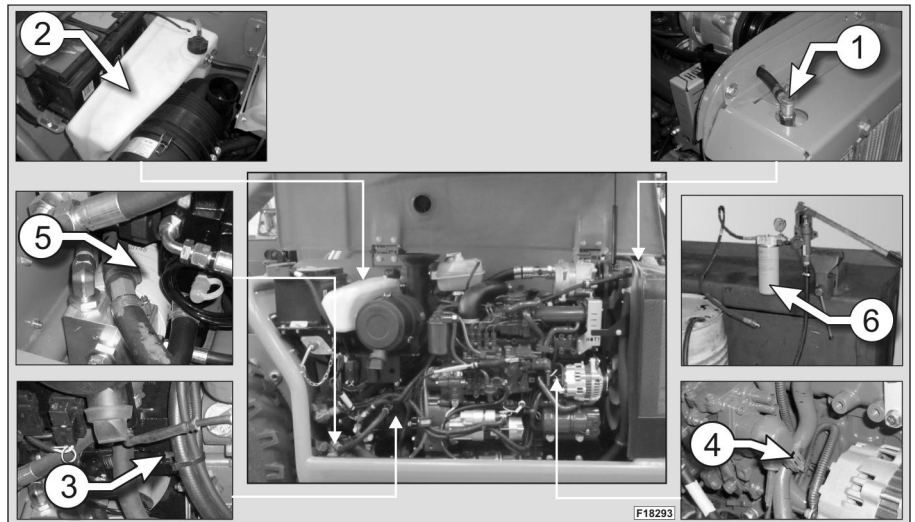

OIL CHANGE

- with the engine running, disconnect contact "F" of the injection pump and wait for the engine to switch off.
- screw out the caps of both radiator "A" and hydrostatic oil tank "B"

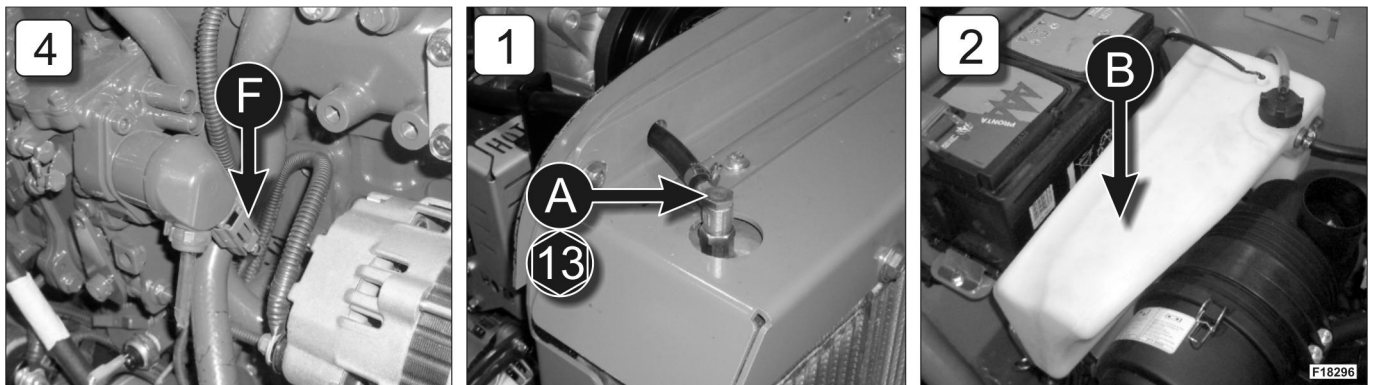

- remove filter "E" and drain oil into a container; to carry out this operation use a chain or band extractor.
- install a new filter "E" for the hydrostatic transmission
- Fill the system exclusively with specific hydraulic oil, which shall be filtered through a 10-micron filter and supplied at a pressure of about 2.5 bar (36 psi).
- For this purpose use a hand pump "M" as shown in the picture (6). Pour oil into the hydrostatic pump through filler cap "C", or by using a pressure tube (connection: M16x2), until the tank is completely full
- Close radiator cap "A" as soon as oil starts coming out and close tank cap "B"
- Remove the hand pump from the pressure tube and close cap "C"

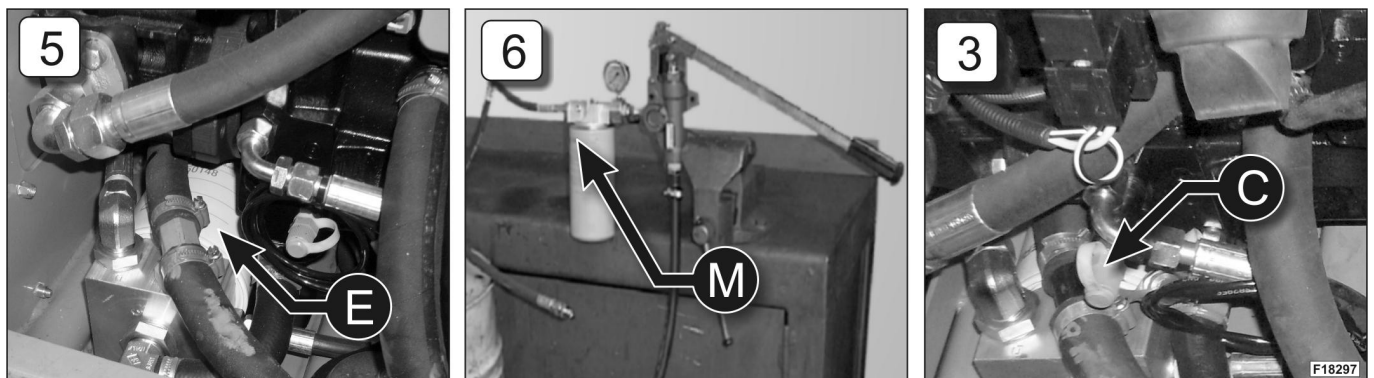



After filling the system, bleed air from it by following the instructions below:

- turn starting key (8) to "ON" position for max. 10 seconds.
- wait 2 minutes to bleed air completely from the system.
- repeat the machine start procedure for two times
- reconnect electrical contacts (F) and start the engine, letting it idle for about 5 minutes with the vehicle standing still.



WARNING! Oil change in the hydrostatic transmission shall be performed by skilled and qualified personnel. Only use the hydrostatic oil indicated in the "OIL TABLE" in chapter STICKERS WITH CONTROL DESCRIPTIONS - LEAFLETS IN THE CABIN. Check oil level in the tank quite frequently and, if necessary, top it up.

• HYDRAULIC OIL

To properly carry out the hydraulic system oil replacement, follow the instructions below:

- Fully retract and lower the telescopic boom
- Stop the machine diesel engine
- Remove filling cap "B"
- Extract and clean the magnets
- Remove discharge cap "C" and empty the hydraulic oil into an appropriate container
- Close back discharge cap "A"
- Pour some new hydraulic oil through filling cap "B"; only use the hydraulic oil indicated in the "OIL TABLE" in chapter "STICKERS WITH CONTROL DESCRIPTIONS - LEAFLETS IN THE CABIN"
- Check that the level of the hydraulic oil poured into the system is about 5 mm from indicator glass "A". Close back filling cap "B".

The system total capacity is 70 l (18 gal)

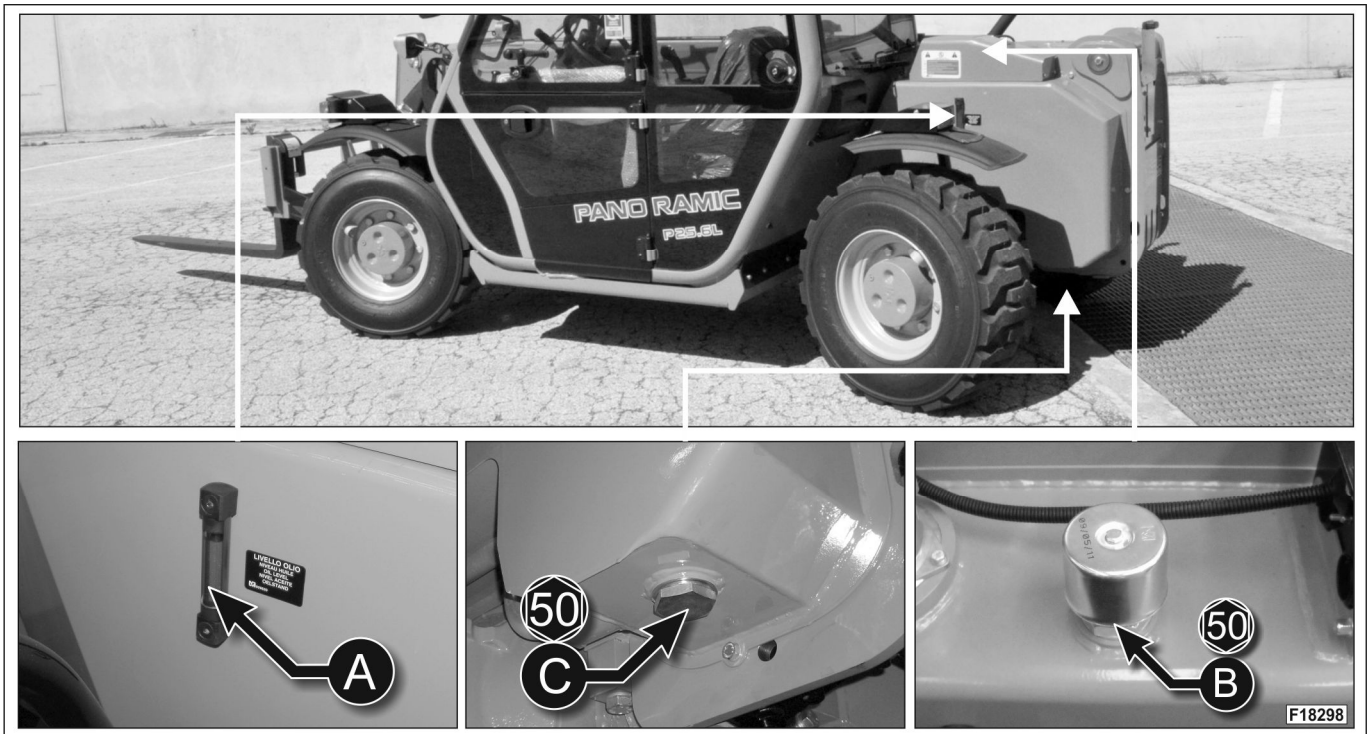



• FRONT AND REAR DIFFERENTIALS OIL

To properly carry out the differential oil replacement, follow the instructions below:

- Stop the machine diesel engine
- Operate on one differential at a time
- Remove filling cap "A"
- Remove discharge cap "B" and collect the differential oil into an appropriate container
- Close back discharge cap "B"
- Pour some new differential oil through filling cap "A" until it starts flowing out; only use the differential oil indicated in the "OIL TABLE" in chapter "STICKERS WITH CONTROL DESCRIPTIONS - LEAFLETS IN THE CABIN". Close back filling cap "A".

The system total capacity is 5,1 litres for front axle and 4,4 for rear axle.

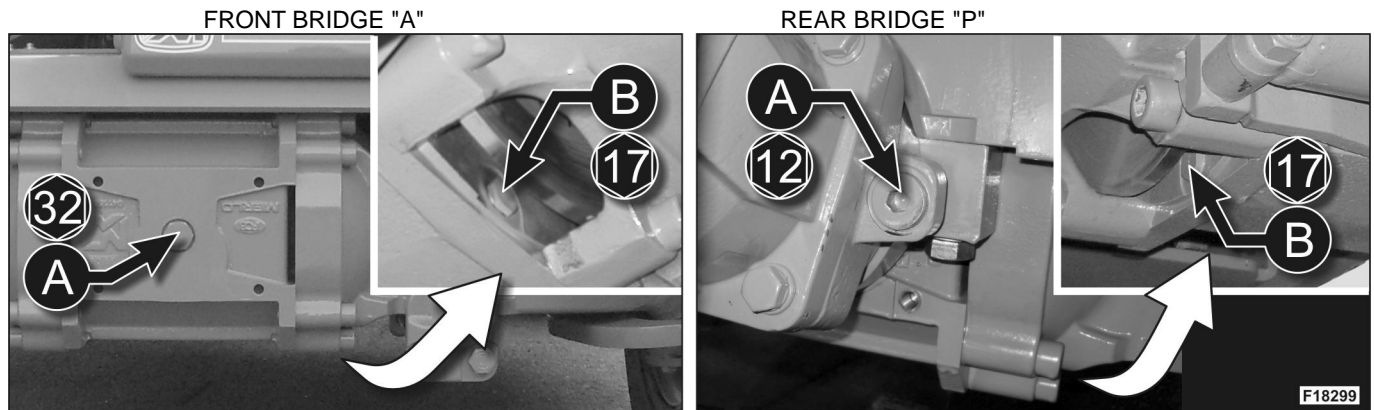

• REDUCTION HUB OIL

To perform the reduction hub oil change correctly, please follow the instructions below.

- work on one reduction hub at a time
- place the machine in such a way that the level plug "A" is facing downwards (picture 1)
- remove level plug "A" and drain reduction hub oil into a proper container
- reinstall level plug "A"
- place the machine in such a way that the level plug "A" is vertically aligned with the wheel centre (picture 2)
- remove level plug "A"
- pour new reduction hub oil through filler cap "A", until it comes out; only use the reduction hub oil shown in the "OIL TABLE" of chapter "STICKERS WITH CONTROL DESCRIPTIONS - LEAFLETS IN THE CABIN"
- close level plug "A"

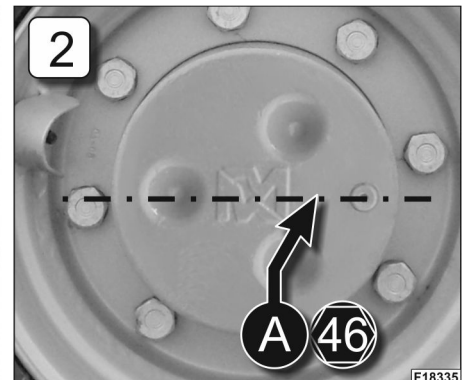
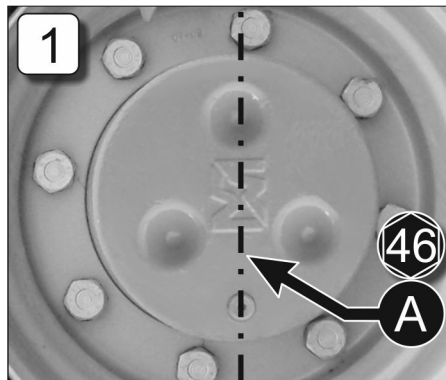

Repeat the same operations for the other reduction hubs too.

The overall system capacity is 0,8 l (0,83 quart)

• BRAKE FLUID

Drain fluid and refill, system bleeding must be carried out by skilled personnel.

The overall system capacity is 300 ml (10 fl oz)

**GENERAL MAINTENANCE**

• INTRODUCTION

This chapter describes all the general maintenance operations to be performed on the machine based on its actual operating conditions, without sticking to any rigorous schedule.



WARNING! Before carrying out the following, please, carefully read the instructions in the chapter **ORDINARY MAINTENANCE**.

• SLIDING RUNNERS ADJUSTMENT OF THE TELESCOPIC BOOM

If play between the boom sections becomes excessive or the carriage isn't correctly parallel to the ground the sliding runners of the boom need to be adjusted as follows:

- position the machine on a flat, perfectly level surface
- engage the parking brake
- correctly level the machine (if fitted with TILTING or SUSPENSIONS)
- remove the protective mufflers "P" from the lock nuts
- loosen the side runners and the lower M12 screws

- hook a bridgecrane "C" to the end of the telescopic boom (as shown in the photo) in order to lift the second boom section bringing it in contact with the second boom section. Alternatively, it is possible to place the carriage on the ground on a perfectly flat base, of small dimensions and centrally positioned with respect to the boom. Lower the telescopic boom in order to lift the second boom section bringing it in contact with the first. In both cases do not force the contact manoeuvre between the booms so as not to risk damage to the structure of the telescopic boom.
- place a 1 metre long checking rod "X" symmetrically on the carriage
- position a spirit level "Y" in the centre of the rod "X"
- loosen all lower screws then tighten them to a torque of 1Kgm (7.24 quart) beginning with those at the centre of each runner and proceeding in a criss-cross fashion. Then tighten the side screws of both parts of the boom to a torque of 1Kgm again proceeding in a criss-cross fashion;
- remove the bridgecrane or, if a base on the ground has been used, lift the telescopic boom.

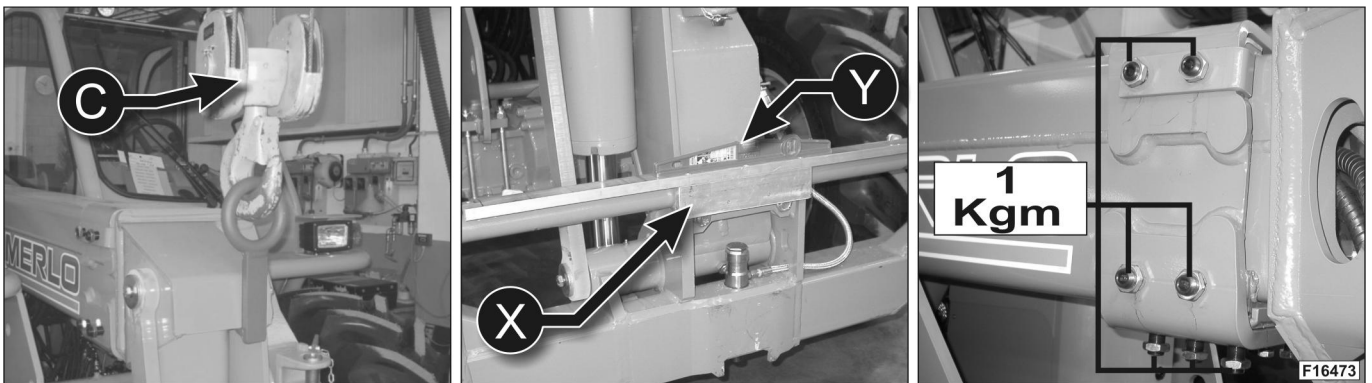
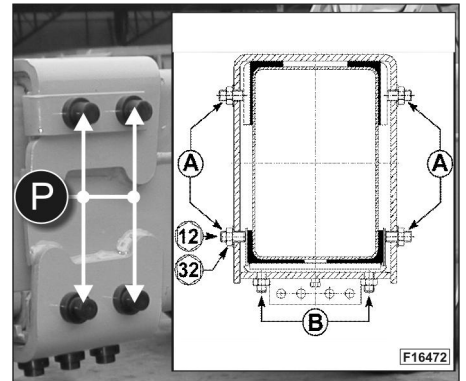

- check the planarity of the carriage with the spirit level "Y".
- if the carriage isn't level individual adjustment of the lower runner which is to be lowered needs to be carried out. To do this, first all the side screws need to be loosened then the 2 lower external screws of the runner to be lowered need to be unscrewed. Adjustment is done acting on the single central screw "G" until the spirit level shows that the carriage is perfectly level. At this point the 2 lower screws and all the side screws need to be tightened to a torque of 1Kgm (7.24 quart)
- tighten all lock nuts
- completely extend the telescopic boom checking that the percentile of inclination of the boom never exceeds $\pm 0,3\%$.



After having adjusted the sliding runners of the boom it is possible that there will not be symmetrical play between the runners themselves and the upper part of the boom as shown in the photo.

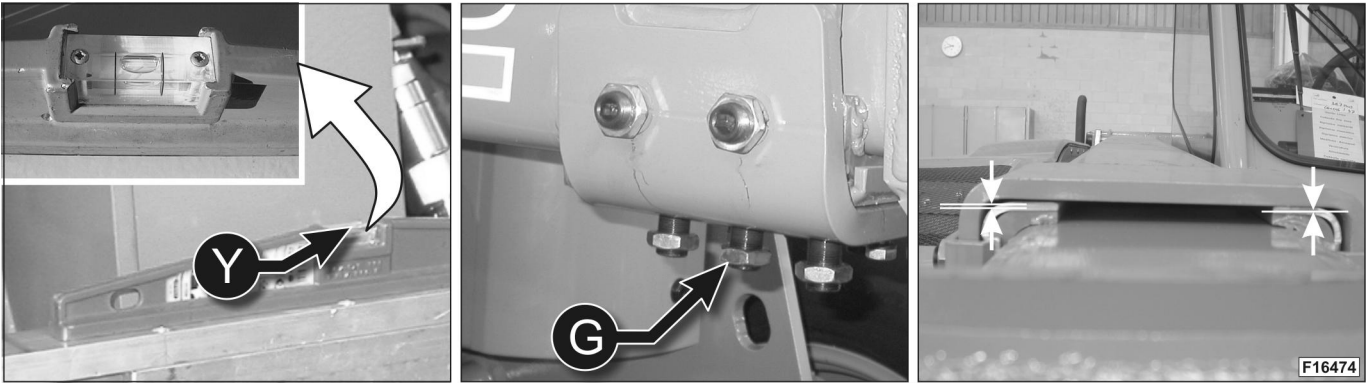

• COOLING SYSTEM

If you need to replace the engine cooling liquid, proceed as follows:

DISCHARGE OF THE COOLING SYSTEM

- Place the machine on a flat surface
- Stop the diesel engine and let it cool off
- Using a strong piece of cloth, loosen pressurised cap "B" and release the system pressure.



WARNING!

Never remove the pressurised filling cap "B" if the diesel engine is still hot, as the cooling liquid, still under pressure, could flow out in a dangerous manner.

Also, make sure that, during the system discharge/filling phases, the cooling liquid does not get in contact with any body part. Always refer to the information on the used product label.

To use the machine in maximum safety conditions, always use the supplied pressurised cap. If this is lost or damaged, contact Merlo Technical Support Service and request it as a spare part.

- remove clamp "C" and disconnect duct "D" from the radiator
- remove drain plug "E" of the engine block located in the inner part of the engine compartment.
- drain the system completely
- check the duct and clamp wear level; if necessary, replace them (it is advisable to perform a visual inspection of both ducts and clamps every 500 hours to check for any sign of wear)
- if necessary, rinse the system with clean water mixed with a detergent

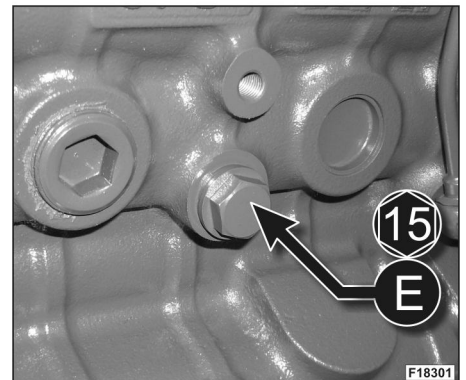
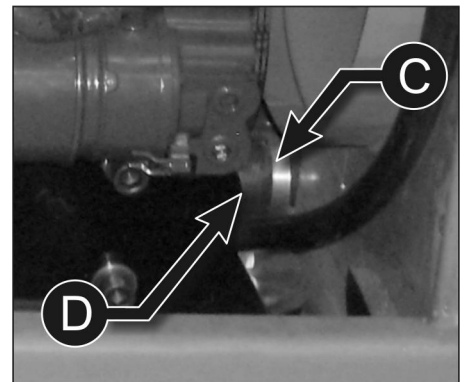
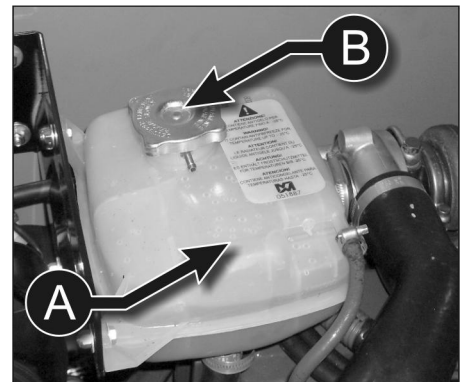

FILLING UP OF THE COOLING SYSTEM

- close drain plug "E" of the engine block
- put in place duct "D" and tighten its clamp "C"
- slowly fill the cooling system (use the coolant shown in the engine manual) until the coolant is visible inside expansion tank "A"
- the level inside expansion tank "A" shall fall within the "MIN" and "MAX" marks shown on the indicator plate
- close the expansion tank with its pressurized cap
- start the Diesel engine and let it run for a few minutes
- check for any leak in the system
- check that the coolant level always falls within the two marks shown on the sticker applied on the expansion tank; if this is not the case, fill up coolant



NOTE! For further information, refer to the attached engine manual.



The system total capacity is 6,2 litres.

CLEANING OF THE RADITOR CORE

Should you need, clean the radiating mass using a jet of water at a maximum pressure of 30 bar or using compressed air and directing the jet in the directio of arrow "3"

Should it be necessary to clean the inside of compartment "B" due to any material settled there, carry out the following operations:

- lift locking device "L"
- release bracket "S" from the retainer
- lift the straw protection, and clean compartment "B"

To close the straw protection grid again, carry out the following operations:

- lower the straw protection grid
- couple bracket "S" to the retainer on the chassis
- lower locking device "B"

Before starting your machine, check that the straw protection grid is correctly in place.

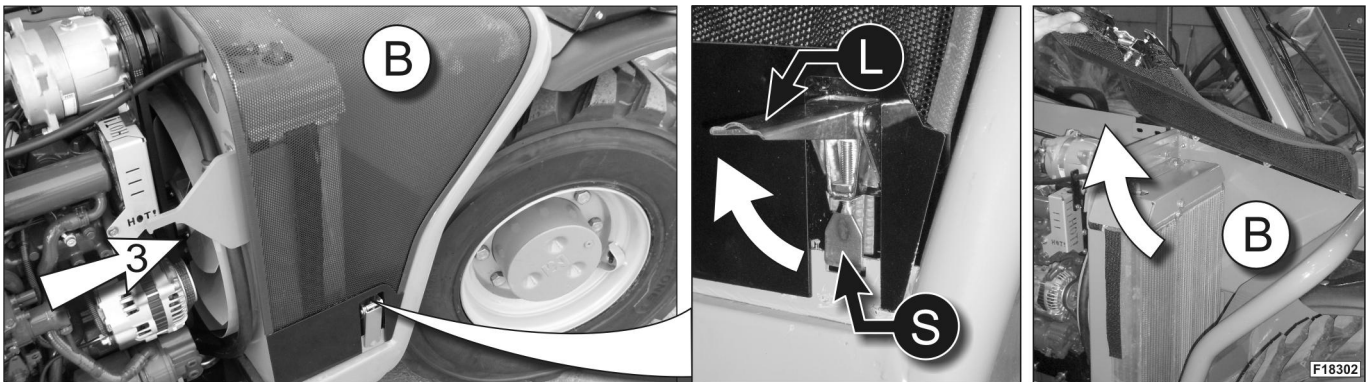

• ENGINE OIL

Periodically check the engine oil as follows:

- Place the machine on a flat ground and switch off the diesel engine
- Wait a few minutes so that the engine cools off and let the engine oil flow into the oil sump
- Check the oil level by extracting stick "A"; the level must be above the "miniumum" notch



WARNING! If the oil level is below the "minimum" notch, do not start the diesel engine.

Do not fill the engine oil tank above the "maximum" level.

To obtain more accurate information, it is recommended to check the oil level before starting your working day and when the engine is cold.

For all other information on the use and maintenance of the diesel engine, refer to the related manual.

If needed, unscrew filling cap "B" and fill up with the engine oil indicated in paragraph "OIL TABLE" in chapter "STICKERS WITH CONTROL DESCRIPTIONS - LEAFLETS IN THE CABIN".

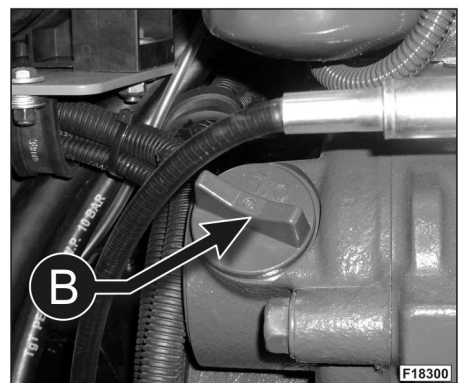
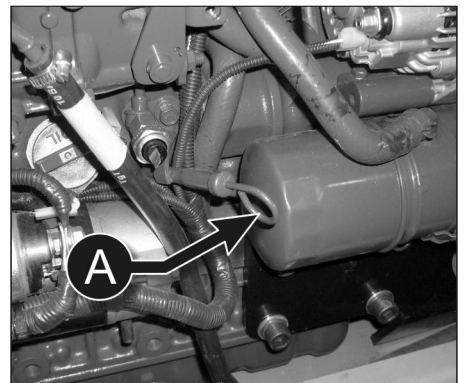



• BRAKE PEDAL ADJUSTMENT

It is necessary to adjust slack if the brake pedal is moving excessively; in order to solve the problem, carry out the following operations:

- loosen nut "A".
- either screw or unscrew dowel screw "B" depending on the kind of adjustment you want to perform, so that a maximum allowance of 1 mm can be obtained
- lock nut "A" on the fork while holding the dowel screw still.

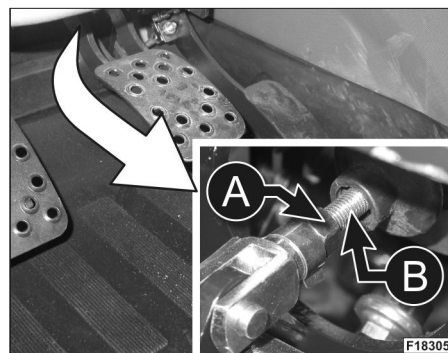

• CATALYTIC EXHAUST (upon request)

In case of excessive smoking from the exhaust, the necessary operations on the engine must be carried out.

If the trouble has last for a long period of time, the catalytic exhaust must be removed from the machine and internally cleaned through a simple immersion in hot soaped water.

It must be then carefully rinsed and dried. Avoid the use of detergents or solvents.

In any case the cleaning must be carried out at intervals of not less than 200 hours.

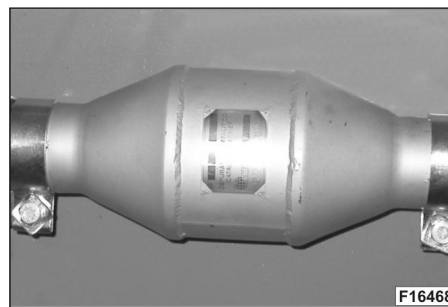

• VEHICLE AND ATTACHMENTS CLEANING



WARNING ! All the described operations have to be carried out with the engine off (it is advisable to take the starting key off from the dashboard).

To clean correctly keep to the following instructions:

- wear the suitable protective means (gloves, masks, glasses, overalls, etc.)
- do not use inflammable liquids and acids or products which could chemically attack the vehicle parts
- do not clean moving or overheated parts.
- to clean the inside of the cab you can use the same products used for cars. Pay particular attention to taking off dust, grease or other from the vehicle controls.
- to clean the outside of the vehicle and the engine, it is advisable to use a washer, keeping in mind the following:
 - make sure that all filler caps (of the radiator, of the oil tank for both the hydraulic system and the hydrostatic transmission, of the fuel tank) are tightened correctly, and check that the handle of the battery cut-out switch is in the "ON" position (for further information please refer to chapter "ELECTRICAL EQUIPMENT")
 - do not work if water pressure and temperature are higher, respectively, than 100 bar (1440 psi) and 80° C (175°F)
 - keep the washing nozzle at not less than 20 cm (8 in) from the surface you want to wash
 - do not insist with the jet on only one point but wash with wide movements.
 - take care not to turn the jet directly on plates, in order not to damage them
- After the washing, carefully dry the glasses and the rear-view mirror.

• WINDSCREEN WASHER LIQUID TANK

Fill tank "A" situated inside the cab with the specific liquid available on the market.

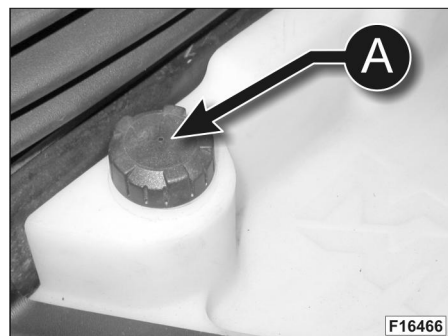



• BRAKE SYSTEM DRAINAGE

Bleeding consists in eliminating air from the braking system.

It is necessary to bleed air from the system whenever hydraulic parts of such system are removed.

Carry out all the operations required to bleed air from the braking system on both axles, but only on the calipers equipped with screw "A"

- Firmly press down the brake pedal.
- Loosen the drainage screw (A).
- Re-close the drainage screw (A).
- Operate the brake pedal repeatedly.
- Repeat the first operation until liquid escapes from the screw without air.

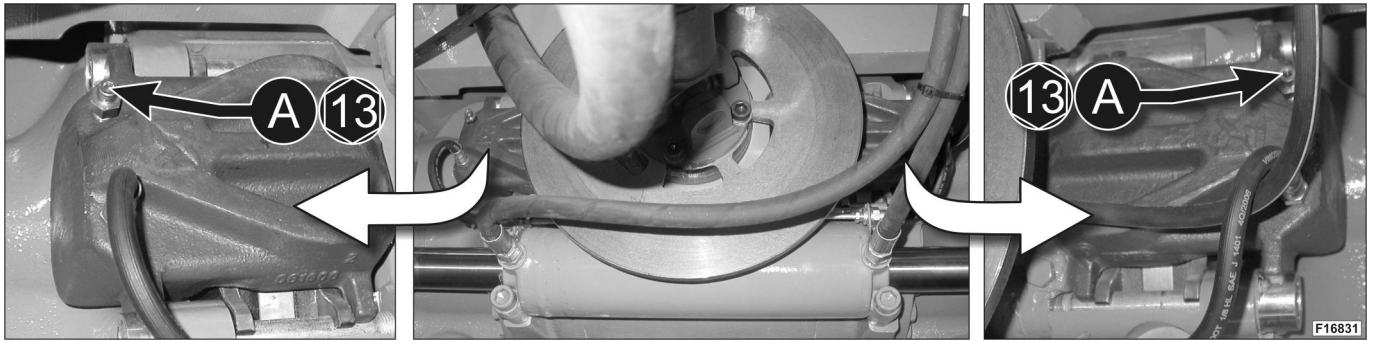

TROUBLE SHOOTING

Should your machine not work correctly, please refer to the following table, so as to identify and eliminate the cause of the problem. The operator is allowed to carry out just some operations, while the most complex ones shall be carried out by Merlo Technical Support Service.

FAILURE	CAUSE	REMEDY
HYDRAULIC SYSTEM	- Oil level is too low/ too high	Restore the correct oil level
	- Oil type is not suitable	Change the oil type
	- Oil is dirty or contains water	Change the oil
	- Oil is cold at start	Let the oil warm up
	- Leak in the system	Eliminate the leak
	- Presence of air in the oil	Eliminate air
	- Hoses are throttled	Eliminate throttling
	- Return filter is dirty/ clogged	Replace the filter
Should you notice any other failures in the hydraulic system (pump, valves, cylinders, etc.), please contact Merlo Technical Support Service.		
ELECTRICAL EQUIPMENT	- Battery is flat	Charge it
	- Electrolyte level is low	Fill it up
	- Connections are slack/ rusted	Restore normal conditions
	- Fuses are blown	Search for failure cause – Replace fuses
	- Alternator belt is slack	Adjust belt tension
Should you notice any other failures in the electrical equipment, please contact Merlo Technical Support Service.		
BRAKING SYSTEM	- Excessive brake pad wear	Replace brake pads. Please contact Merlo Technical Support Service
	- Low brake fluid level	Check the system for any leak, then fill it up
	- Air in the system	Purge air from the system
ENGINE	Please refer to the troubleshooting section in the Engine Manual. For any operations other than routine maintenance to be carried out on certain parts (injection pump, injectors, valves, etc.), please contact Merlo Technical Support Service.	
HYDROSTATIC TRANSMISSION	For these operations please contact Merlo Technical Support Service.	



• HOW TO START ENGINE WHEN BATTERY IS DOWN



CAUTION! Before working on the battery, carefully read the instructions found in paragraph "BATTERY" and in chapter "ELECTRIC SYSTEM". Check polarity before connecting the cables. Avoid any contact between the two cables.

Should you start the engine with the battery down, act as follows:

- 1) Take an emergency battery having the same characteristics and two cables.
- 2) Connect the cable to the (+) and (-) of the battery inside the machine and, then, to the correspondent (+) and (-) of the emergency battery.
- 3) Start the engine and disconnect the cables.

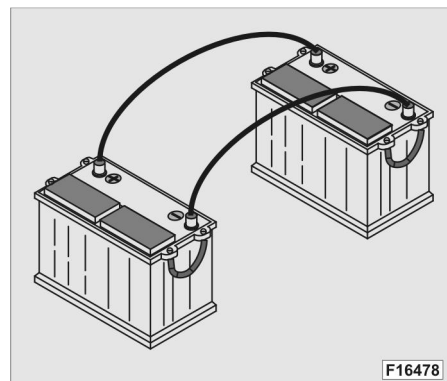

• EMERGENCY PUMP FAILS TO RELEASE PARKING BRAKE

Shouldn't it be possible to release the parking brake using the emergency pump, act as follows (see paragraph "TOWING OF THE MACHINE" in the section "OPERATING INSTRUCTIONS"):

- chock the wheels to lock the machine in place
- hold the brake caliper chamber (A) still
- fully loosen the adjusting screw (B)

Before restarting the vehicle tighten the adjusting screw and check the system correct working.

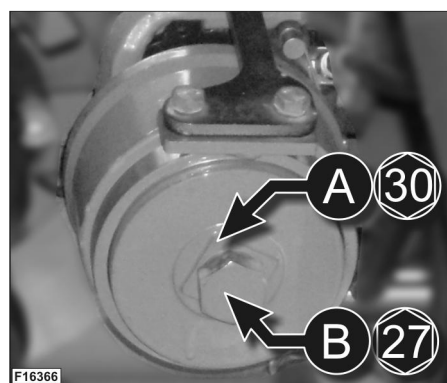

• BLEEDING OF THE MOTOR FEEDING SYSTEM

The bleeding of the feeding system is necessary to remove the air present into the system when you are run out of fuel.

Once you have refuelled up the tank, carry out the following operations:

- loosen unions "A", "B", "C" and "D"
- activate manually the pump "P" until fuel without air comes out from unions.
- tighten unions "A", "B", "C" and "D"
- go on pressing the pump "P" and, in the meantime, start the motor by turning the ignition key (8) present in the cab.

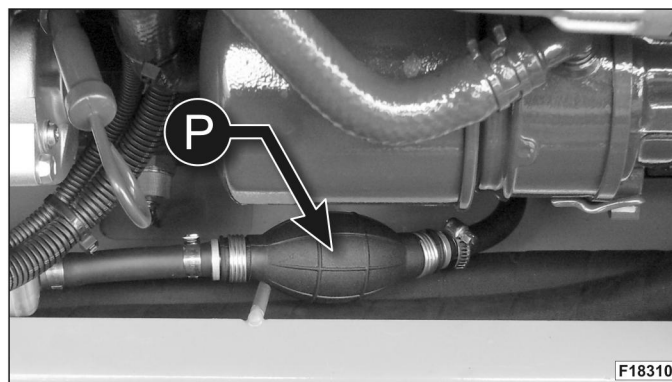
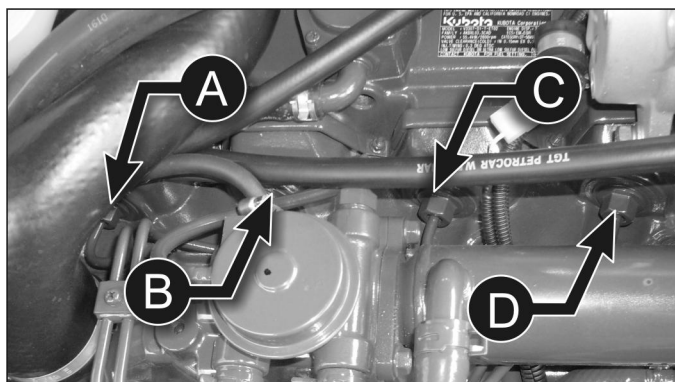

END OF CHAPTER

**INDEX**

PERIODICAL INSPECTIONS REGISTRATION CARD	2
AUDIBLE-VISUAL ALARM AND BLOCKING OF THE MOVEMENTS OF THE ROLL-OVER PROTECTION SYSTEM.....	3
STEERING MODES OPERATION	3
PLATES AND INSTRUCTIONS.....	3
INSTRUCTION HANDBOOK FOR OPERATING AND MAINTENANCE	3
POWER STEERING PRESSURE CALIBRATION	4
HYDRAULIC SYSTEM OIL PRESSURE	4
RAMS' STOP VALVES	4
PARKING BRAKE	4
SPIRIT LEVEL CALIBRATION	5
END OF CHAPTER	5

**PERIODICAL INSPECTIONS REGISTRATION CARD**

The following card must be reproduced (i.e. photocopied) and used to record the inspections to be carried out following the periods as reported in the table. In case the cell between the line and the column is not highlighted, the inspection is not necessary. The operations hereafter listed must be carried out following the expirations in working hours or in months, whichever come first. Inspections of the machine and following recording on the card must be carried out by the person in charge of the operations (e.g. Owner, site manager, etc.). The duly filled in cards must be kept by the machine user and must be at disposal for possible checking by the authorized inspection organisation.

TYPE OF MACHINE	CHASSIS NUMBER		CHECKER NAME			
FUNCTION TO BE CHECKED	PERIOD IN HOURS / MONTHS					
	Each 250 hours or 2 months		Each 500 hours or 6 months		Each 1000 hours or 1 year	
	Check Date	Restoration Date	Check Date	Restoration Date	Check Date	Restoration Date
Check of the overload prevention system acoustic alarm	.../.../...	.../.../...	.../.../...	.../.../...	.../.../...	.../.../...
Check of the overload prevention system visual alarm	.../.../...	.../.../...	.../.../...	.../.../...	.../.../...	.../.../...
Check of the overload prevention system movements lock-out	.../.../...	.../.../...	.../.../...	.../.../...	.../.../...	.../.../...
Check of the presence inside the cab of the instruction handbook for operating and maintenance	.../.../...	.../.../...	.../.../...	.../.../...	.../.../...	.../.../...
Check spirit level calibration	.../.../...	.../.../...	.../.../...	.../.../...	.../.../...	.../.../...
Check of the the hydraulic system pressure			.../.../...	.../.../...	.../.../...	.../.../...
Check of the rams' stop valve			.../.../...	.../.../...	.../.../...	.../.../...
Check of the parking brake			.../.../...	.../.../...	.../.../...	.../.../...
Check of the three modes steering			.../.../...	.../.../...	.../.../...	.../.../...
Check of the power steering pressure calibration			.../.../...	.../.../...	.../.../...	.../.../...
Check of the presence and conditions, inside the cab and on the machine, of the instructions plates					.../.../...	.../.../...
Signature:			Machine total working hours:			



WARNING ! Before carrying out any of the following operations, which require machine movement, make sure that no persons or things are in the machine's operating area.

In case of operations which require the lifting of a load, make sure that the machine is on a compact surface and that it is properly levelled.

Should these checks reveal any problems, do not use the machine until the problems have been resolved.



AUDIBLE-VISUAL ALARM AND BLOCKING OF THE MOVEMENTS OF THE ROLL-OVER PROTECTION SYSTEM



ATTENTION!

We recommend using a load of about 2/3 of the maximum load for the test.

- 1) Work on flat, solid ground
- 2) Align the wheels with the frame.
- 3) Install the forks on the machine.
- 4) Pick up the load with the forks (Fig.5)
- 5) Lift the load about 500 mm off the ground (Fig.6)
- 6) Extract the arm until the roll-over protection system intervenes (audible-visual alarm, blocked movements).



MAKE SURE that:

- The machine has not tilted.
- The indicator light for the activation of the frontal roll-over protection control (54) on the DASHBOARD has come on.
- The buzzer in the cab sounds continuously.
- The letter "X" to which the intervention refers corresponds to the one on the load diagram in the cabin. The system's intervention tolerance is ± 400 mm with respect to what is described in the diagram (fig. 7)
- The only movement allowed is the retraction of the arm.

If this is not the case, contact the local Distributor or Dealer to get technical assistance.

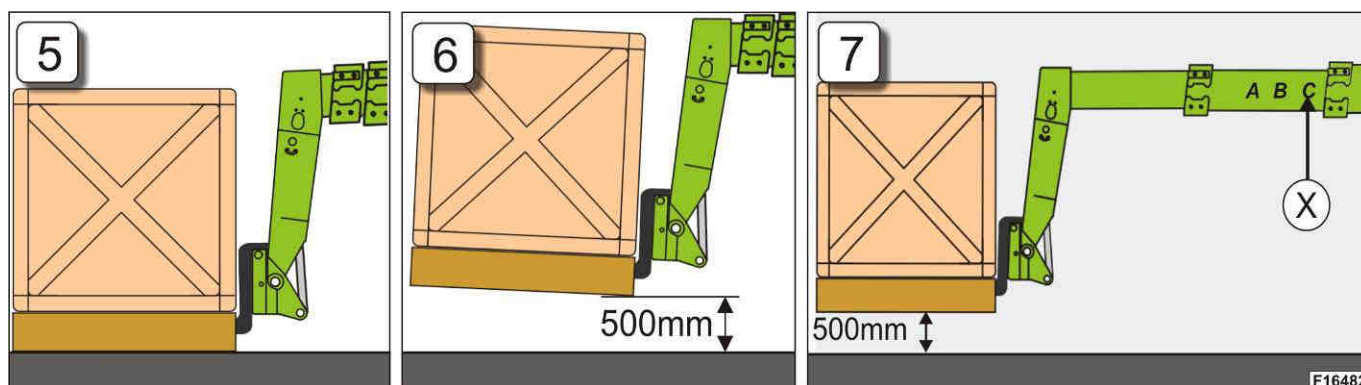

STEERING MODES OPERATION

Check the right operation of the steering in the three possible modes:

- four wheel steering
- front wheel steering
- crab steering

PLATES AND INSTRUCTIONS

Check that all plates are on the machine, that all instructions sheets are in the removable holder inside the cab and that they are in good condition.

The main plates are described in the relative chapters of this instruction handbook and in case of damage or loss they must be replaced quoting as reference the part number written on the part.

INSTRUCTION HANDBOOK FOR OPERATING AND MAINTENANCE

Check that the instruction handbook is inside the cab and that it is in good conditions. In case of loss or damage, request a duplicate by mentioning, if possible, the reference code at the bottom of the cover, otherwise use the SAV number of the machine.



POWER STEERING PRESSURE CALIBRATION

- Stop the engine and take away the key from the board.
- Connect the small hose, coming from the gauge, to the pump pressure plug (as for the checking of the HYDRAULIC OIL SYSTEM PRESSURE).
- Start the engine.
- Keep the transmission in neutral position.
- Accelerate up to 1800 r.p.m..
- Steer up to lock to left or right direction and, while keeping the unit steered, read the pressure from the gauge in the cab.
- The pressure must be over 180 bar (180 kg/cm²).

HYDRAULIC SYSTEM OIL PRESSURE

- Stop the engine and take away the key from the board.
- Connect the small hose in the engine compartment to the "A" pressure plug.
- Start the engine.
- Retract the boom.
- Accelerate up to 2400 r.p.m., while keeping the boom retract command operating.
- Check on the gauge in the cab that the pressure is between 205 and 215 Bar.

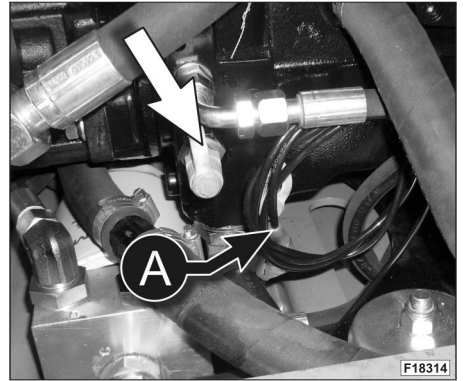

WARNING ! In case the gauge indicates a pressure value different from the forecasted one, please ask for assistance from qualified Merlo Service personnel.

When the checking of the pressure is ended, disconnect the small hose from the pump and rearrange it in the engine compartment.

RAMS' STOP VALVES

- Start the engine. Take a load, using the forks, with a weight of at least 2/3 of the machine's maximum capacity.
- Hook up to the forks end a plumb line with a length of about 3 meters.
- Stabilize the machine (if the machine is equipped with stabilizers)
- Lift the boom up to an height of about 3,5 meters.
- Extract the boom for about 0,5 meters.
- Stop the engine and operate the distribution levers as to lower the boom and to rotate the forks downward.
- Release the levers
- Measure the distance "D" between the end of the plumb line and the ground.
- Lock the cab and wait for about 30'.
- Repeat the measurement.

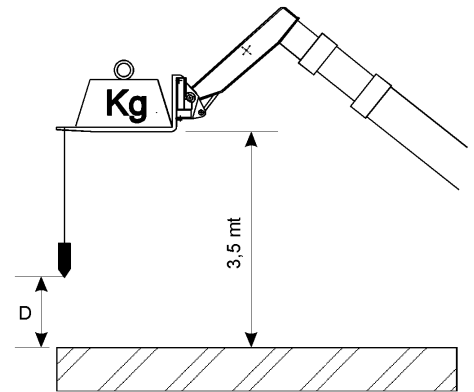

The difference between the two measurements must not be over 25 mm, in case the difference is over 25 mm request the MERLO service assistance.

PARKING BRAKE

- Start the engine and shift to the 2nd speed.
- Check that the speed has been shifted by running the machine for a short stretch.
- Apply the parking brake.
- Keeping applied the brake pedal, shift the gear to forward position and accelerate up to 1600 r.p.m..
- Slowly release the brake pedal.
- If the machine does not move, accelerate up to the maximum r.p.m. The machine must stay still.



SPIRIT LEVEL CALIBRATION

Check the correct calibration of the spirit level on the machine dashboard.

- Position a spirit level "A" of a minimum length of 400 mm (as illustrated).
- level the machine using the relative devices mounted on the machine (stabilizers, tilting or suspension type). Should the machine not be fitted with any such devices, move the machine to an area of flat ground in order to find a point at which the spirit level "A" is perfectly centred.
- Adjust screws "C" until the spirit level in the level gauge is perfectly centred.

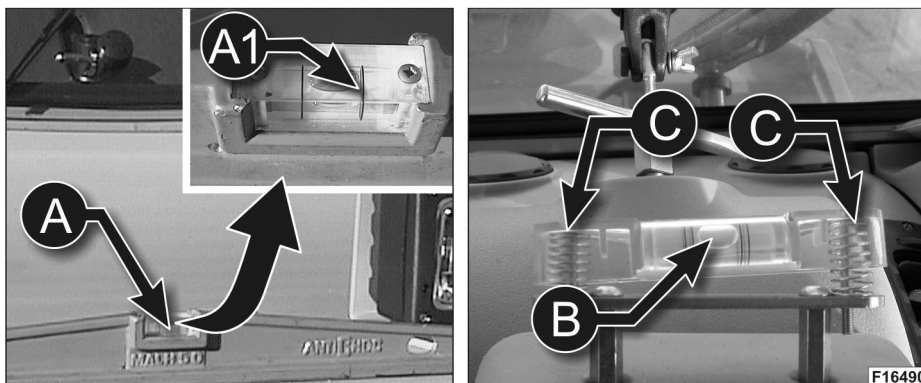

END OF CHAPTER



INDEX

GENERAL INSTRUCTIONS FOR THE USE OF THE MACHINE AS AN AGRICULTURAL TRACTOR (ONLY FOR 25.6)	2
LOCKING OF THE FRONT AND REAR DIFFERENTIAL ELEMENT	4
INDICATOR OF REAR WHEEL CENTERING ON THE MACHINE AXIS	4
SUPPORT BRACKET FOR THE TRAILER SERVICE BRAKE LEVER	4
FRONT TOW HOOK	4
REAR TOW HOOK (4 TONS).....	5
WINDSCREEN WIPER ON ROOF.....	5
CAR RADIO.....	5
SUNBLIND.....	5
WORK LIGHTS	6
MIXER BUCKET	6
CONTROL SELECTOR FOR THE CONTINUOUS DELIVERY OF HYDRAULIC OIL.....	6
REAR SERVICE LINE	7
REAR ELECTRIC SOCKET	7
DIRECTION INDICATORS FAILURE FOR AGRICULTURAL TRAILER.....	7
COLD CLIMATE OIL.....	8
HOT CLIMATE OIL.....	8
HYDRAULIC BRAKING SYSTEM	9
JOYSTICK (4 FUNCTION)	10
JOYSTICK (5 FUNCTION)	11
JOYSTICK (5 FUNCTION) WITH SELECTION OF THE DRIVE DIRECTION	12
EXTRA-COMFORT PNEUMATIC SEAT GRAMMER	14
PNEUMATIC SEAT	15
CONDITIONER.....	16
END OF CHAPTER	16



This chapter describes all the available accessories for this vehicle, based on the Merlo official price list. Before using any accessory mentioned in the present chapter, it is necessary to read and fully understand the instructions on its operation. If the accessory installation or operation is not entirely clear, please contact your dealership or Merlo Technical Support Service.



WARNING!

Only use Merlo S.p.a. approved accessories, homologated for their use on your vehicle.

It is forbidden to use an accessory without reading and understanding its installation and operation instructions.

Should more than one accessory be installed on the machine, the relative controls may be in a position that differs from that indicated in the manual supplied with the machine. In any event please refer to the symbol that appears next to the command itself, so that even if it should be in a different position can be identified by the relative symbol which is described in the manual.

GENERAL INSTRUCTIONS FOR THE USE OF THE MACHINE AS AN AGRICULTURAL TRACTOR (ONLY FOR 25.6)

This paragraph provides general instructions to be followed if your machine is type-approved as an AGRICULTURAL TRACTOR in compliance with Directive 2010/52/EU.

• PROTECTION LEVEL OF THE OPERATORS PROTECTION STRUCTURE

For information on the protection level of the operators protection structure of your machine please refer to the "CAB TYPE-APPROVAL PLATE" in chapter "TECHNICAL DATA OF YOUR MACHINE".

• PREVENTION OF CONTACT WITH HAZARDOUS SUBSTANCES

Prevention level 1 in compliance with the EN 15695-1:2009 standards. Cab not suitable for any use implying contact with hazardous substances.

• HOW TO TOW AN AGRICULTURAL TRACTOR

For information on how to tow your machine if it is type-approved as an AGRICULTURAL TRACTOR (Directive 2010/52/EU) please refer to the instructions provided in paragraph "MACHINE TOW", chapter "OPERATING INSTRUCTIONS".

• WHERE TO PLACE HYDRAULIC JACKS

Should you lift your machine to replace a tyre, you can apply hydraulic jacks where shown below:

A) front lifting spot: place your hydraulic jack by the middle part of the front axis of your machine, as shown by the arrow

B) rear lifting spot: place your hydraulic jack by the middle part of the rear axis of your machine, as shown by the arrow

Please refer to the "TABLE FOR THE DETERMINATION OF PERMISSIBLE MASSES, AXLE LOADS AND TYRE LOAD CAPACITIES" in this chapter to identify the kind of hydraulic jack which best suits your needs.

• GENERAL INSTRUCTIONS FOR THE USE OF ATTACHMENTS OR TRAILERS COUPLED TO YOUR MACHINE

Before using your machine with mounted attachments, trailers and interchangeable towed attachments, strictly follow the instructions provided both in the operation and maintenance manual of your machine and in the manuals of the attachments or trailers. Never use your machine with mounted attachments, trailers and interchangeable towed attachments without following said instructions.



WARNING! Never stand in between the machine and the trailer or towed attachment.

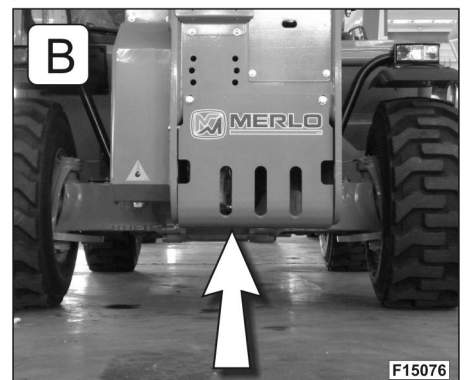
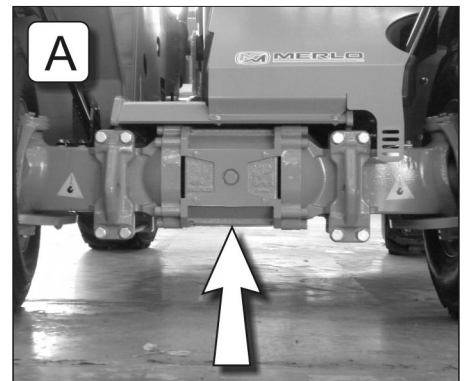



• TABLE FOR THE DETERMINATION OF PERMISSIBLE MASSES, AXLE LOADS AND TYRE LOAD CAPACITIES

Please refer to the table below for permissible total masses on both front and rear axle and for the maximum permissible tyre load of your machine.

These data are also useful to identify the most suitable hydraulic jack to be used for tyre replacement (see paragraph "WHERE TO PLACE HYDRAULIC JACKS" in this chapter).

MACHINE	TECHNICALLY PERMISSIBLE MASS (kg)			PERMISSIBLE TYRE LOAD PER AXLE (kg)	
	TOTAL	FRONT	REAR	FRONT	REAR
P25.6	6400	3200	3200	3200	3200

• TABLE FOR THE DETERMINATION OF MAXIMUM PERMISSIBLE LIMITS FOR TOWED MASSES

Please refer to the table below for maximum permissible limits for towed masses, for the determination of the maximum vertical load on the rear tow hook, as well as on the available braking systems for trailers.



NOTE!

The data regarding the maximum permissible limits for towed masses are also shown on the type-approval plate in the front part of the cab (see paragraph "IDENTIFICATION AND TYPE-APPROVAL PLATES" in chapter "TECHNICAL DATA OF YOUR MACHINE").

MACHINE	TOW CAPACITY (kg)					VERTICAL LOAD ON THE HOOK (kg)
	NO BRAKING	MECHANICAL BRAKING	INERTIA BRAKING	HYDRAULIC BRAKING	PNEUMATIC BRAKING	
P25.6	2500	5000	6000	12000	NO	420

• TABLE FOR THE DETERMINATION OF DRIVER-PERCEIVED NOISE LEVEL (measured in compliance with Directive 2009/76/EC) AND OF NOISE OF TRACTORS IN MOTION (measured in compliance with Annex VI to Directive 2009/63/EC).

MACHINE	NOISE OF THE MACHINE IN MOTION (in compliance with Directive 2009/63/EC)	DRIVER-PERCEIVED NOISE (in compliance with Directive 2009/79/EC)	
		With cab window closed	With cab window open
P25.6	83	85	86

• TABLE FOR THE DETERMINATION OF VIBRATION LEVEL (in compliance with Directive 78/764/EEC)

The table below shows the vibrations transmitted by the driver's seat, divided depending on the make and type of seat installed on the tractor. Check the model installed in the cab of your machine, and refer to the data provided below.

SEAT MODEL	CATEGORY	CLASS	TYPE-APPROVAL	DRIVER'S WEIGHT	A _{ws} [m/s ²] (Dir. 78/764)
KAB Seating 11T6	A	I / II / III	e11 0997	light	1.13
				heavy	1.01
KAB Seating 156, 15T6, 15E1, 15T1	A	I / II / III	e11 0995	light	1.13
				heavy	1.01
ACTIVIO SERIES SEAT – S698	A	II / III	e13 0021	light	1.64
				heavy	0.64
ACTIVIO SERIES SEAT – S55	A	II / III	e13 0020	light	1.17
				heavy	0.98
GRAMMER MSG95	A	II / III	100514	light	1.04
				heavy	0.64

**LOCKING OF THE FRONT AND REAR DIFFERENTIAL ELEMENT**

It operates by using the button ref. A:

button pressed = differential lock engaged
 button released = differential lock free

the warning light lit (ref. 88) indicates that the differential lock is engaged.



IMPORTANT! On hard surfaces do not operate steering with differential lock engaged.

Let the lock engaged in a fixed way exclusively to operate on the silage.

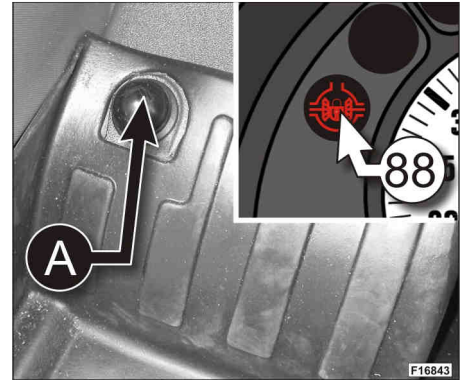
**INDICATOR OF REAR WHEEL CENTERING ON THE MACHINE AXIS**

Before carrying out a transfer on public roads, it is mandatory to align the wheels of the rear bridge to the longitudinal axis of the machine by proceeding as follows:

- select corrected steering or crab steering
- carry out the steering manoeuvre until the rear bridge wheels are parallel to the machine axis. The completed alignment is shown by indicator "A" which lights up on control panel "P1".

Before carrying out a transfer on public roads, select steering on the front axis (lever 29 in position "B").

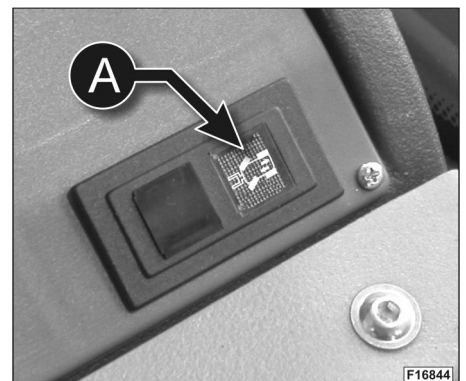
**SUPPORT BRACKET FOR THE TRAILER SERVICE BRAKE LEVER**

The support bracket "A" for the service brake lever is located inside the driver's cabin, beside the driver's seat. If he wishes so, the customer may fit a lever onto this bracket to engage the service brake if the connected trailer does not have a hydraulic or pneumatic braking system.

The use conditions for the trailer service brake are the following:

- Maximum transfer speed: 20 km/h
- Trailer total weight: 5000 kg

**FRONT TOW HOOK**

Front tow hook "A" shall only be used for vehicle rescue operations if there is no other way of intervening.
 If possible, it is recommended to rely on the dedicate rescue vehicles.

The towing force must be at least 1500 kg.

For further information on the machine towage, refer to paragraph "INSTRUCTIONS FOR DRIVING YOUR MACHINE ON THE ROAD" in chapter OPERATING INSTRUCTIONS.

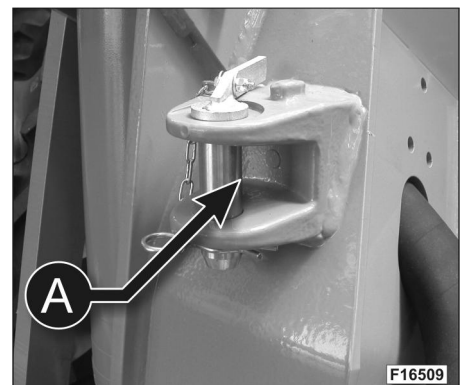



REAR TOW HOOK (4 TONS)

Use the fixed tow hook for building sites if:

- it is necessary to tow the vehicle on public roads (see also paragraph "MACHINE TOWING" in chapter "OPERATING INSTRUCTIONS")
- it is necessary to tow trailers or other equipment within a building site. In this case, the maximum towable weight must be less than 4000 kg.

The vertical charge maximum value on the towing hook is indicated inside the registration documents for public road circulation.



WARNING!

It is forbidden to use this type of hook to tow trailers or other equipment on public roads.

WINDSCREEN WIPER ON ROOF

To activate the windscreen wiper on the vehicle roof, press button "C" located on the electric motor of the wiper itself.

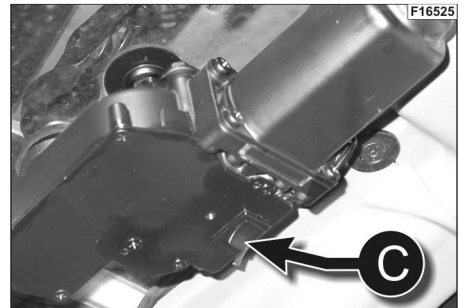

CAR RADIO

The radio is installed in the compartment under the left glove box.

The picture of the radio only has illustrative purposes and may not correspond to the radio actually mounted on the vehicle.

For information on the radio use, refer to the corresponding manual.



SUNBLIND

In resting conditions, sunblind "A" is rolled up at the top edge of the cabin window (Fig. 1).

In order to cover the top area of the cabin window, unroll sunblind "A" until it is hooked to the appropriate fastening brackets "B" (Fig. 2).

If you also need to cover a part of the cabin front window, further unroll sunblind "A" until it is hooked to fastening brackets "C" (Fig. 3).

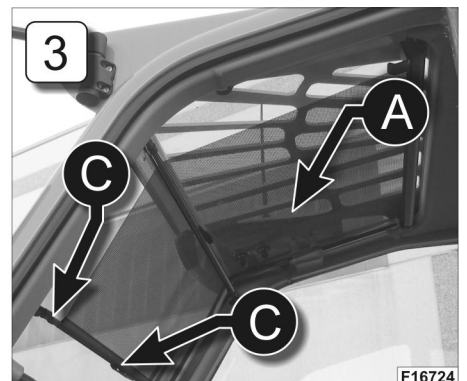
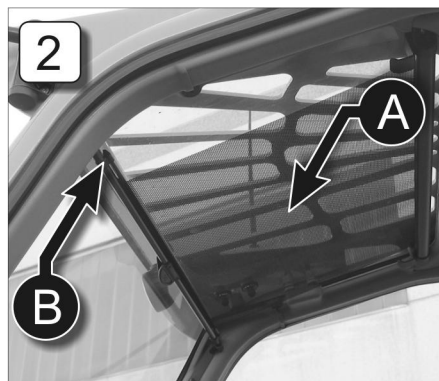
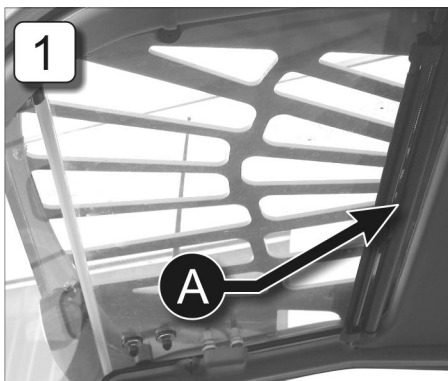

**WORK LIGHTS**

• ON CAB

- Turn the ignition key (8) to position "R" (dial will light up).
- Press button (A) to switch on the front working headlights "A1".
- Press button (P) to switch on the rear working headlights "P1".

• ON TELESCOPIC BOOM

- Turn switch selector "S" in position "1" in order to switch on the additional work lights on boom.
- Turn switch selector "S" in position "0" in order to switch off the additional work lights on boom.

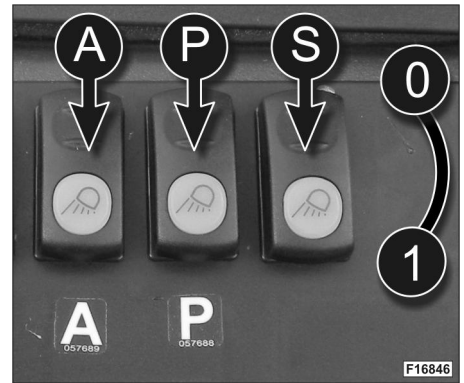
**MIXER BUCKET**

PROPELLER ROTATION

- Rotate switch "S" to position "2"

PROPELLER GUARD OPENING

- Rotate switch "S" to position "1";
- Rotate switch "S" to position "2" when the guard is completely open.

The guard closure occurs in automatic mode by rotating the bucket upwards.



WARNING! The rotation of the propeller with open guard is allowed solely during the loading of the inert materials, manoeuvring from the cab and using the bucket as a loader vane. With switch "S" in position "1", when rotating the bucket upwards, the safety device blocks the propeller rotation. If the machine is left in the condition the oil is liable to overheat.

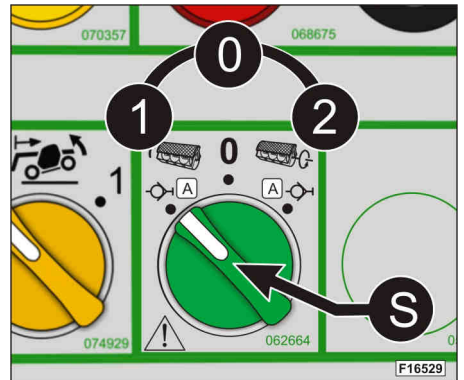

OPENING AND CLOSURE OF THE CONCRETE UNLOADING FLAP

To discharge the concrete:

- Engage the propeller rotation function.
- Engage the unloading function using the radio control supplied (see paragraph relative to the equipment manual)

CONTROL SELECTOR FOR THE CONTINUOUS DELIVERY OF HYDRAULIC OIL

In order to supply with hydraulic oil an attachment connected to the quick couplings on the boom head in a CONTINUOUS manner, operate as follows:

- connect the hydraulic oil delivery conduit to coupling (A), marked with a black band.
- rotate selector (S) to position "1" or "2" to send the hydraulic oil to the quick couplings in a CONTINUOUS MANNER.

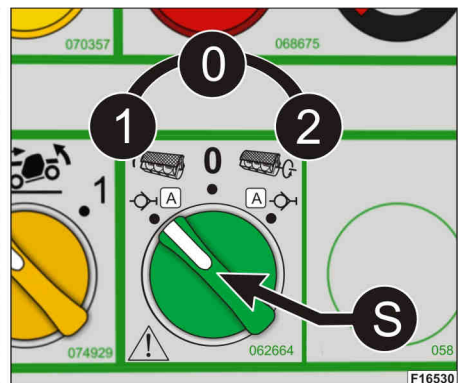
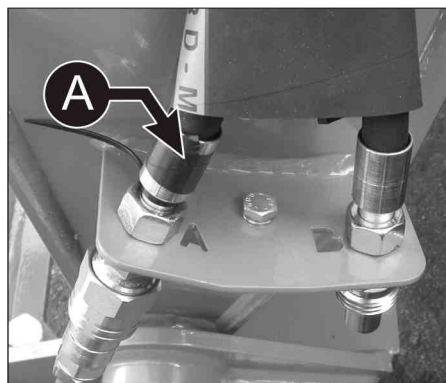

WARNING! Use the controls which enable the continuous delivery of oil to the hydraulic inlets only after correctly connecting the desired attachment to the machine.

The use of attachments which require a CONTINUOUS supply of oil (such as mixers, silo unloaders, etc.) must only last for a short period of time (about ten minutes), so as to prevent the oil in the machine hydraulic system from overheating. MERLO S.p.A. is not responsible for the use of attachments not produced by them or whose assembly on the base vehicle has not been explicitly approved. MERLO S.p.A. declines any responsibility for the construction, operation, safeties and instructions on the correct use of any attachment which it has not certified. Any damage to the machine original parts shall not be recognised.



REAR SERVICE LINE

Move lever (X) in position "A" or "B" in order to use the relative rear service line.



NOTE!

The maximum working pressure of the rear service line is 210 bar.



WARNING!

The hydraulic system of the rear service line is not equipped with valves or seals suitable to keep lifted loads (for example a dumb body). For these kind of use verify that the attachment is equipped with appropriate blocking system against accidental load dropping.



WARNING!

Before starting to work with the rear hydraulic services, be sure to have disconnected both the hydraulic circuit of the attachment locking system and the hydraulic line to the attachment fitted to the front carriage.

When the job is finished disconnect the rear hydraulic lines; if not, when using the attachment fitted to the front carriage, the equipments linked to the rear hydraulic services would be actioned.

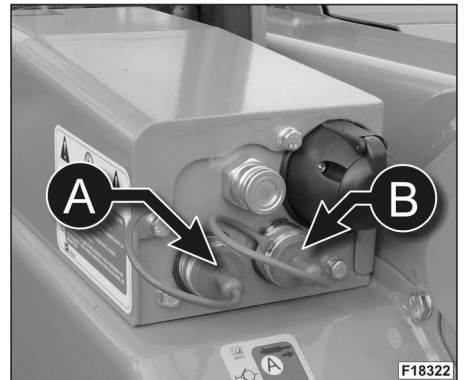
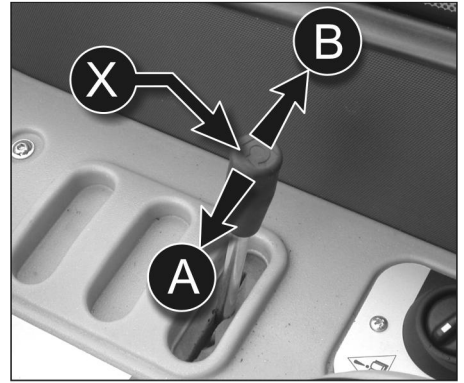

REAR ELECTRIC SOCKET

For the electrical connection of the direction indicators and all the lights of the towed equipment.

Consult the wiring diagram enclosed for electrical connection (in accordance with ISO 1724-80 standard).

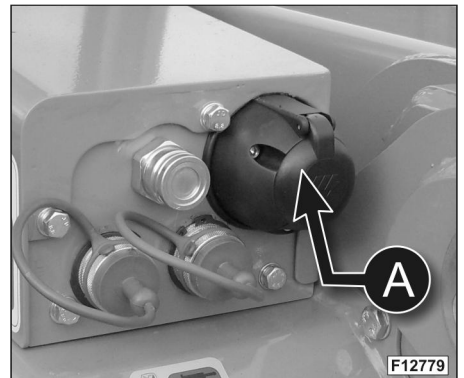

DIRECTION INDICATORS FAILURE FOR AGRICULTURAL TRAILER

When the machine is homologated as agricultural tractor and has a trailer attached, inside the cab there is a warning light (A) that signals to the operator if there is a problem with the trailer's direction indicators.

The system activates automatically with illumination of the orange warning light (A) on the control panel (P1) as soon as the electric plug of the trailer lights is connected to the appropriate socket at the rear of the machine.

In conditions of normal functioning, when the direction indicators are activated, the orange light flashes alternately with the green arrow on the dashboard.

If there are problems in the system, when the indicator lights are activated, the orange light remains constantly illuminated at the side where the problem is.

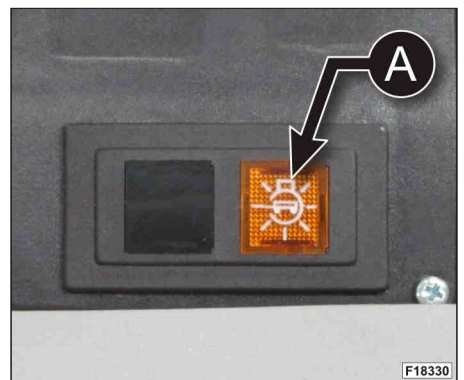

**COLD CLIMATE OIL**

This oil table replaces and supersedes the one found in chapter "STICKERS WITH CONTROL DESCRIPTIONS - LEAFLETS IN THE CABIN".

081858 MERLO S.p.A. Industria Metalmeccanica			
TABELLA OLII - LUBRICANTS - LUBRIFIANTS OELTABELLE - LUBRICANTES			
Impiego - Application Utilisation - Verwendung Aplicación	ESSO	MOBIL	Specifiche - Notes Commentaires Spezifikation Anotaciones
Olio impianto idraulico, servizi e trasmissione idrostatica	HYDRO UNIVIS N22	SHC 524	Viscosità a 40°C= 20,75 cst ISO 3448 = 22
Hydraulic system and hydrostatic transmission			Viscosity at 40°C= 20,75 cst ISO 3448 = 22
Utilisation hydraulique asservissement et système transmission hydrostatique			Viscosité a 40°C= 20,75 cst ISO 3448 = 22
Oel fuer hydraulische Anlage, Dienste hydrost. Getriebe-Anlage			Viskositäet bis 40°C= 20,75 cst ISO 3448 = 22
Aceite instalación hidráulica servicios y transmisión hidrostática			Viscosidad a 40°C= 20,75 cst ISO 3448 = 22

081858 MERLO S.p.A. Industria Metalmeccanica	
I	ATTENZIONE ! OLII DI DIFFERENTI MARCHE NON SONO MISCIBILI. Il trasporto e il commercio degli olii devono sottostare alle leggi europee e nazionali vigenti in materia. Si invitano pertanto i Sig. Clienti a provvedere al loro approvvigionamento attenendosi alle normative citate. Per le operazioni di controllo e sostituzione vedere le informazioni riportate sul manuale di istruzioni.
GB	CAUTION ! DIFFERENT BRAND OIL CANNOT BE MIXED. Oil transportation and trade must be subject to European and local laws in force. Customers are kindly requested to act for their supply following the mentioned rules. For check and replacement operations refer to the information in the instruction handbook.
F	ATTENTION ! LES HUILES DE MARQUES DIFFERENTES NE SONT PAS MISCIBLES. Le transport et le commerce des huiles doivent se soumettre aux lois européennes et nationales en vigueur. Par conséquent on invite Messieurs les clients à son approvisionnement s'en tenant aux normes susmentionnées. Pour les opérations de contrôle et remplacement voir les informations indiquées sur la Notice d'instructions.
D	VORSICHT! MAN KANN NICHT ÖLE VON VERSCHIEDENEN HERSTELLERFIRMEN MISCHEN. Der Transport und der Handel von Ölen müssen die geltende Europäische und Landesgesetze unterliegen. So sind die Kunden gebeten, für Ihre Versorgung die angeführte Normen zu befolgen. Für die Kontroll- und Ersatzstätigkeiten sehen Sie die Auskunfte auf den Bedienungsanleitungshandbuch.
E	¡¡ATENCIÓN!! NO SE DEBEN MEZCLAR ACEITES DE DIFERENTES MARCAS. El transporte y el comercio de los aceites están sujetos a las normas europeas vigentes. Por consiguiente los clientes deben abastecerse en conformidad a las sobrecitadas normas. Referente a las operaciones de control y sustitución consultar el manual de instrucciones.

HOT CLIMATE OIL

This oil table replaces and supersedes the one found in chapter "STICKERS WITH CONTROL DESCRIPTIONS - LEAFLETS IN THE CABIN".

083290 MERLO S.p.A. Industria Metalmeccanica		
TABELLA OLII - LUBRICANTS - LUBRIFIANTS OELTABELLE - LUBRICANTES		
Impiego - Application Utilisation - Verwendung Aplicación	ESSO	Specifiche - Notes Commentaires Spezifikation Anotaciones
Olio impianto idraulico, servizi e trasmissione idrostatica	UNIVIS N68	Viscosità a 40°C= 68 cst ISO 3448 = 68
Hydraulic system and hydrostatic transmission		Viscosity at 40°C= 68 cst ISO 3448 = 68
Utilisation hydraulique asservissement et système transmission hydrostatique		Viscosité a 40°C= 68 cst ISO 3448 = 68
Oel fuer hydraulische Anlage, Dienste hydrost. Getriebe-Anlage		Viskositäet bis 40°C= 68 cst ISO 3448 = 68
Aceite instalación hidráulica servicios y transmisión hidrostática		Viscosidad a 40°C= 68 cst ISO 3448 = 68

083290 MERLO S.p.A. Industria Metalmeccanica	
I	ATTENZIONE ! OLII DI DIFFERENTI MARCHE NON SONO MISCIBILI. Il trasporto e il commercio degli olii devono sottostare alle leggi europee e nazionali vigenti in materia. Si invitano pertanto i Sig. Clienti a provvedere al loro approvvigionamento attenendosi alle normative citate. Per le operazioni di controllo e sostituzione vedere le informazioni riportate sul manuale di istruzioni.
GB	CAUTION ! DIFFERENT BRAND OIL CANNOT BE MIXED. Oil transportation and trade must be subject to European and local laws in force. Customers are kindly requested to act for their supply following the mentioned rules. For check and replacement operations refer to the information in the instruction handbook.
F	ATTENTION ! LES HUILES DE MARQUES DIFFERENTES NE SONT PAS MISCIBLES. Le transport et le commerce des huiles doivent se soumettre aux lois européennes et nationales en vigueur. Par conséquent on invite Messieurs les clients à son approvisionnement s'en tenant aux normes susmentionnées. Pour les opérations de contrôle et remplacement voir les informations indiquées sur la Notice d'instructions.
D	VORSICHT! MAN KANN NICHT ÖLE VON VERSCHIEDENEN HERSTELLERFIRMEN MISCHEN. Der Transport und der Handel von Ölen müssen die geltende Europäische und Landesgesetze unterliegen. So sind die Kunden gebeten, für Ihre Versorgung die angeführte Normen zu befolgen. Für die Kontroll- und Ersatzstätigkeiten sehen Sie die Auskunfte auf den Bedienungsanleitungshandbuch.
E	¡¡ATENCIÓN!! NO SE DEBEN MEZCLAR ACEITES DE DIFERENTES MARCAS. El transporte y el comercio de los aceites están sujetos a las normas europeas vigentes. Por consiguiente los clientes deben abastecerse en conformidad a las sobrecitadas normas. Referente a las operaciones de control y sustitución consultar el manual de instrucciones.



HYDRAULIC BRAKING SYSTEM

Please follow these instructions to correctly use the hydraulic braking system when towing agricultural trailers:

- connection of the trailer braking system
 - Insert the start key (8) into the panel
 - Start the diesel engine
 - Connect the trailer to the tractor tow hook
 - Connect the electric socket (see related paragraph in this chapter)
 - Connect the hydraulic brake outlet coming from the trailer to socket "A" on the trailer
 - Check the correct operation of the trailer lights
 - Carry out a low-speed transfer to check the correct operation of the trailer braking system



WARNING!

In case of stop while the engine is running, engage the vehicle parking brake (37) (the trailer keeps on being non-braked).

In case of stop while the engine is off, the vehicle parking brake is automatically engaged (the trailer keeps on being non-braked).

- disconnection of the trailer braking system

The trailer can be unhooked in two different ways:

WITH THE ENGINE ON

- Engage the vehicle parking brake
- Disconnect conduit "A" of the trailer braking system
- Disconnect the electric socket of the trailer lights
- Unhook the trailer from the tractor tow hook
- Disengage the vehicle parking brake and slowly drive away

WITH THE ENGINE OFF

- Stop the vehicle engine; the vehicle and the trailer parking brakes are automatically engaged
- Disconnect conduit "A" of the trailer braking system
- Disconnect the electric socket of the trailer lights
- Unhook the trailer from the tractor tow hook
- Disengage the vehicle parking brake
- Start the engine and slowly drive away



JOYSTICK (4 FUNCTION)

Your machine is equipped with a single-lever joystick (1) that allows you to control the 4 main movements of the machine during operation:

- 1) RAISING / LOWERING OF THE TELESCOPIC BOOM
- 2) UPWARD / DOWNWARD ROTATION OF THE FORKS
- 3) EXTENSION / RETRACTION OF THE TELESCOPIC BOOM
- 4) OPERATION OF ATTACHMENTS FITTED ON THE CARRIAGE

To control the first two movements shift the joystick both longitudinally and transversally, while for the two remaining movements use control rollers "R1" and "R2".

The speed of the movements to be made is in direct ratio to:

- the tilt angle of the joystick (the wider the angle, the higher the speed of the movement);
- to the control rollers "R1", "R2" rotation (the wider the rotation is, the higher the speed will be)
- the rotation speed of the diesel engine (the higher the engine rpm, the higher the speed of the movement).

The movement stops automatically when you release either the joystick or the roller. Depending on load conditions, it is possible to combine movements.

- JOYSTICK LEVER (1) IN POSITION:

- A = raising of the telescopic boom
- B = lowering of the telescopic boom
- C = downward tilt of the forks
- D = upward tilt of the forks

- CONTROL ROLLER "R1"

- 1 = extension of the telescopic boom
- 2 = retraction of the telescopic boom

- CONTROL ROLLER "R2"

- 3 = uncoupling/control of attachments
- 4 = control of attachments

- JOYSTICK ENABLE BUTTON "U"

Press and hold button "U" to enable the controls on joystick (1). Indicator lamp (209) on control panel (P1) illuminates to show the operator that joystick controls are enabled.



WARNING! Before operating the machine, please mark off the area where the machine needs to be operated, in order to keep both people and vehicles away from it.

Should you need to operate the machine near overhead lines, the person in charge of safety shall inquire the minimum safety distance from such lines from the manager of said lines, as well as from the authorities in charge of safety and health in the workplace; in this way all necessary precautions shall be taken and potential accidents shall be prevented. For further information please refer to paragraph "INSTRUCTIONS FOR A CORRECT USE OF THE MACHINE NEAR OVERHEAD LINES" in chapter "OPERATING INSTRUCTIONS".

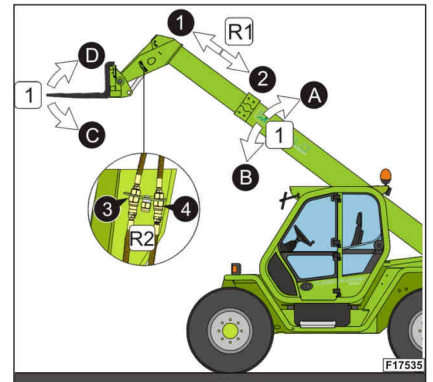
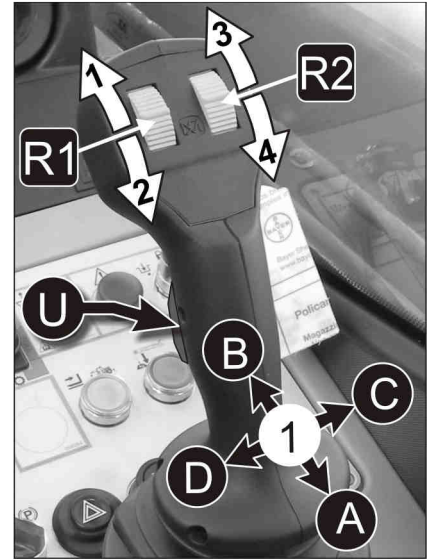



JOYSTICK (5 FUNCTION)

Your machine is equipped with a single-lever joystick (1) that allows you to control the 5 main movements of the machine during operation:

- 1) RAISING / LOWERING OF THE TELESCOPIC BOOM
- 2) UPWARD / DOWNWARD ROTATION OF THE FORKS
- 3) EXTENSION / RETRACTION OF THE TELESCOPIC BOOM
- 4) OPERATION OF ATTACHMENTS FITTED ON THE CARRIAGE (AUX)
- 5) OPERATION OF ATTACHMENTS FITTED ON THE CARRIAGE (AUX 1)

To control the first 2 movements shift the joystick both longitudinally and transversally, while for the 3 remaining movements use control rollers "R1", "R2" and "R3". The speed of the movements to be made is in direct ratio to:

- the tilt angle of the joystick (the wider the angle, the higher the speed of the movement);
- to the control rollers "R1", "R2", "R3" rotation (the wider the rotation is, the higher the speed will be)
- the rotation speed of the diesel engine (the higher the engine rpm, the higher the speed of the movement).

The movement stops automatically when you release either the joystick or the roller. Depending on load conditions, it is possible to combine movements.

- JOYSTICK LEVER (1) IN POSITION:

- A = raising of the telescopic boom
- B = lowering of the telescopic boom
- C = downward tilt of the forks
- D = upward tilt of the forks

- CONTROL ROLLER "R1"

- 1 = extension of the telescopic boom
- 2 = retraction of the telescopic boom

- CONTROL ROLLER "R2" (AUX)

- 3 = uncoupling/control of attachments
- 4 = control of attachments

- CONTROL ROLLER "R3" (AUX 1)

- 5 = control of attachments
- 6 = control of attachments

- JOYSTICK ENABLE BUTTON "U"

Press and hold button "U" to enable the controls on joystick (1). Indicator lamp (209) on control panel (P1) illuminates to show the operator that joystick controls are enabled.



WARNING! Before operating the machine, please mark off the area where the machine needs to be operated, in order to keep both people and vehicles away from it.

Should you need to operate the machine near overhead lines, the person in charge of safety shall inquire the minimum safety distance from such lines from the manager of said lines, as well as from the authorities in charge of safety and health in the workplace; in this way all necessary precautions shall be taken and potential accidents shall be prevented. For further information please refer to paragraph "INSTRUCTIONS FOR A CORRECT USE OF THE MACHINE NEAR OVERHEAD LINES" in chapter "OPERATING INSTRUCTIONS".

Shift the plug of socket "A" to the supporting socket "B"

The dual-purpose tools are equipped with an electrical cable which must be connected to the electrical plug "A" on the head section of the boom.

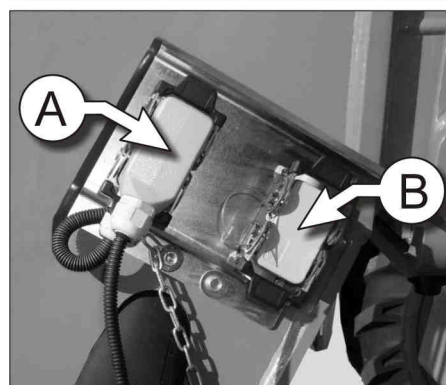
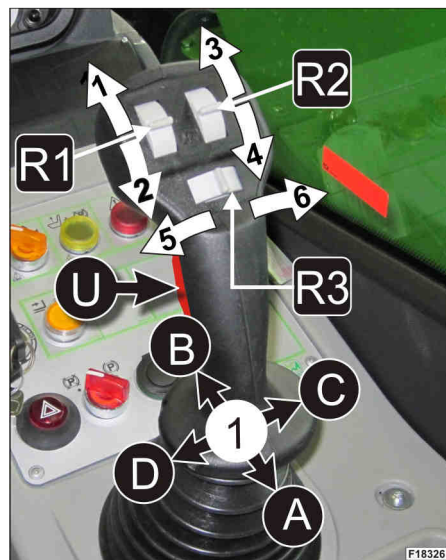

**JOYSTICK (5 FUNCTION) WITH SELECTION OF THE DRIVE DIRECTION**

Your machine is equipped with a single-lever joystick (1) that allows you to control the 5 main movements of the telescopic boom and to select the drive direction (forward/reverse) of the machine.

The controls provided on the joystick are:

- RAISING / LOWERING OF THE TELESCOPIC BOOM
(move the joystick forwards or backwards)
- UPWARD / DOWNWARD ROTATION OF THE FORKS
(move the joystick to the left or right)
- EXTENSION / RETRACTION OF THE TELESCOPIC BOOM
(use thumb wheel R1)
- OPERATION OF ATTACHMENTS FITTED ON THE CARRIAGE (AUX)
(use thumb wheel R2)
- OPERATION OF ATTACHMENTS FITTED ON THE CARRIAGE (AUX 1)
(use thumb wheel R3)
- SELECTION OF FORWARD / REVERSE DRIVE
(use buttons F, R, N)

- TELESCOPIC BOOM CONTROLS

The speed at which the movement is performed is proportional to:

- the tilt angle of the joystick (the further the joystick is moved, the faster the movement)
- the rotation of thumb wheels "R1", "R2", "R3" (the further the wheel is rotated, the faster the movement)
- the rotation speed of the diesel engine (the higher the engine rpm, the faster the movement).

The movement stops automatically when the joystick or the respective thumb wheel is released. The possibility of combining the movements depends on the load conditions.

- JOYSTICK LEVER (1) IN POSITION:

- A = raising of the telescopic boom
- B = lowering of the telescopic boom
- C = downward tilt of the forks
- D = upward tilt of the forks

- CONTROL ROLLER "R1"

- 1 = extension of the telescopic boom
- 2 = retraction of the telescopic boom

- CONTROL ROLLER "R2"

- 3 = uncoupling/control of attachments
- 4 = control of attachments

- CONTROL ROLLER "R3"

- 5 = control of attachments (AUX 1)
- 6 = control of attachments (AUX 1)

- JOYSTICK ENABLE BUTTON "U"

Press and hold button "U" to enable the controls on joystick (1). Indicator lamp (209) on control panel (P1) illuminates to show the operator that joystick controls are enabled.

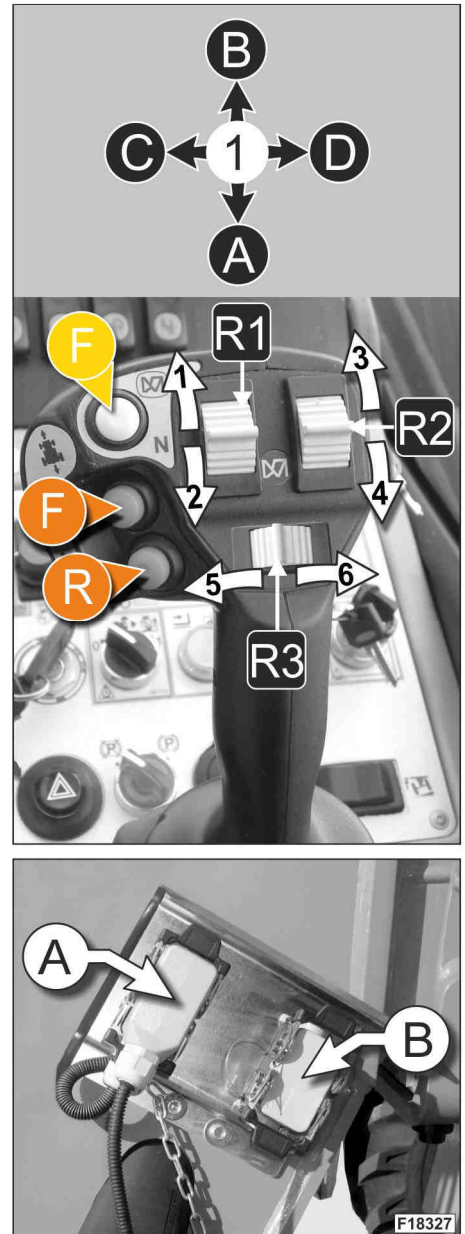



- SELECTION OF THE DRIVE DIRECTION (FORWARD / NEUTRAL / REVERSE)

The joystick (1) mounts buttons for selection of the drive direction (forward / neutral /reverse).

- Button F: forward drive selection
When forward drive is selected, the indicator light (LF) located next to the steering column is steadily illuminated.
- Button N: neutral selection
When neutral is selected, both indicator lights (LF and LR) are extinguished. The machine does not move when the accelerator is pressed.
- Button R: reverse drive selection
When reverse drive is selected, the indicator light (LR) located next to the steering column is steadily illuminated.

The (F,N,R) buttons on the joystick have the same identical functions as the (F,N,R) buttons located on the forward/revers drive selector next to the steering column and both may be used (for example, you can select forward drive by pressing the "F" button on the joystick and subsequently press the "N" button on the forward/reverse drive selector (20) to select neutral, and so on...).

Fore further information on the safe operation of this control, please refer to the instructions in the paragraph "FORWARD/ REVERSE DRIVE SELECTOR (20)" in this chapter.



CAUTION! *It is only possible to change the drive direction when the machine is travelling in first gear (slow travel). Do not change the drive direction when the machine is in second gear (fast travel).*

When reverse drive is selected, the reverse alarm system will be activated automatically and an intermittent audible warning signal will sound.



WARNING! *Before operating the machine, please mark off the area where the machine needs to be operated, in order to keep both people and vehicles away from it.*

Should you need to operate the machine near overhead lines, the person in charge of safety shall inquire the minimum safety distance from such lines from the manager of said lines, as well as from the authorities in charge of safety and health in the workplace; in this way all necessary precautions shall be taken and potential accidents shall be prevented. For further information please refer to paragraph "INSTRUCTIONS FOR A CORRECT USE OF THE MACHINE NEAR OVERHEAD LINES" in chapter "OPERATING INSTRUCTIONS".

Shift the plug of socket "A" to the supporting socket "B"

The dual-purpose tools are equipped with an electrical cable which must be connected to the electrical plug "A" on the head section of the boom.

**EXTRA-COMFORT PNEUMATIC SEAT GRAMMER**

The pneumatic seat Grammer is installed in place of the standard one. Therefore, the following instructions replace those found in chapter "CABIN" of the present operator manual.



WARNING! It is forbidden and it is extremely dangerous to adjust the driver's seat while the vehicle is moving. Position the driver's seat so that the driver can easily reach the vehicle controls.

1) SEAT FORWARD/BACKWARD SLIDING

To regulate the seat horizontal sliding, lift lever "A" and move the seat forwards or backwards until the desired position is reached. Once the seat has been adjusted, release lever "A" and check that the seat is locked into the desired position.

2) BACKREST ADJUSTMENT

Rest your back on the backrest, then lift lever "B" to incline it as desired. Once the seat has been adjusted, release lever "A" and check that the backrest is locked into the desired position.

3) LUMBAR ADJUSTMENT

Rotate handle "C" in both directions to adjust the desired lumbar support level.

4) SUSPENSION ADJUSTMENT

This pneumatic seat can automatically adjust to the ideal height and suspension level according to your body weight.

To correctly adjust the seat height and suspension, properly sit on the seat, then lift lever "D" for a few seconds; the seat automatically assumes the ideal position.

If the set height is not comfortable, you can still manually use lever "D" to raise or lower the seat.

If, while driving, the seat dampens the roughness of the road by reaching its top or bottom end stop, the system automatically regulates the seat height, so that the maximum driving comfort is always ensured.

5) ACTIVATION OF THE LONGITUDINAL ANTI-SHOCK SYSTEM

Your pneumatic seat is fitted with a longitudinal anti-shock system which makes driving on roads and working at a building site more comfortable.

Lever "E" is used to activate the anti-shock system: when in position "1" the anti-shock is activated, in position "0" it is disabled.

6) SAFETY BELT

The safety belt use conditions are the same as those found in paragraph "CABIN".

7) DOCUMENT POCKET

Always keep the use and maintenance manual of your vehicle in the document pocket "G", located behind the seat.

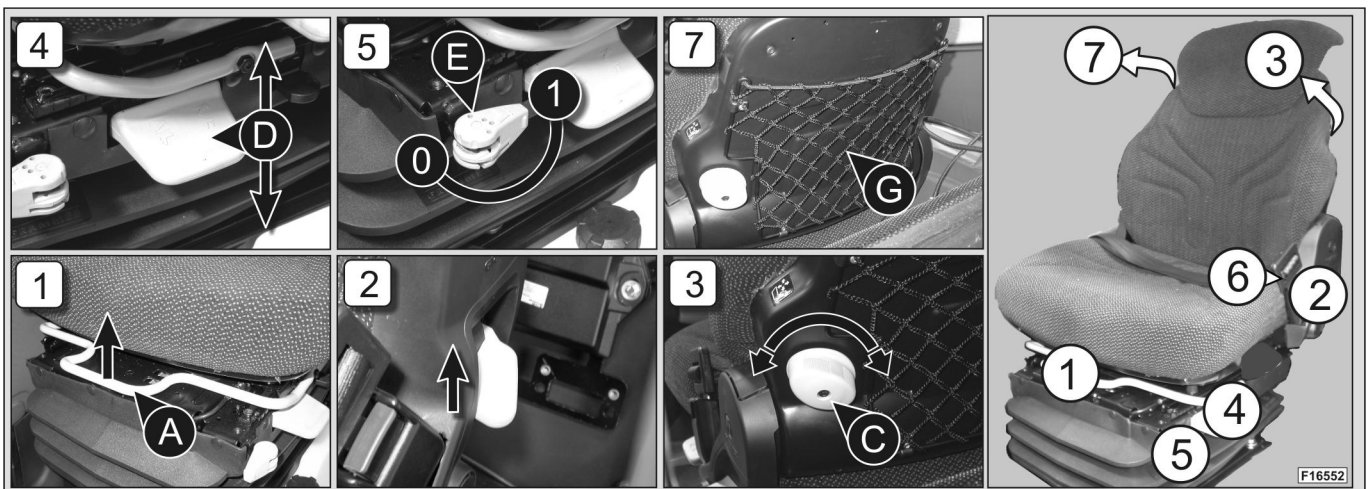



PNEUMATIC SEAT

Seat shift (1):

Lift lever "S" upwards, slide the seat forwards or backwards to obtain the required position and release the lever.

Height adjustment (2):

The seat height can be adjusted by means of the hand lever "M", placed on the front side of the seat frame.

To lower the seat, pull outwards the hand lever "M".

To lift the seat, turn the start key in position "R" and press the "M" hand lever.

Suspension adjustment (3):

To adjust the seat suspension use handle "A" located at the front side of the seat frame. Sit on the seat and turn the handle until just the right degree of suspension is achieved for one's weight. (direction "R" to tighten the suspension, direction "S" to slacken the suspension)

Back adjustment (4):

Sit with your back firmly against the seat back.

Lift lever "L" upwards to position the back to the required angle.

Document holder pocket (5)

Located behind the seat for holding the machine documentation and small objects.

Always keep the "INSTRUCTION HANDBOOK FOR OPERATING AND MAINTENANCE" in the document holder pocket (T).

The machine is fitted with a pneumatic seat with a longitudinal anti-shock system making for more comfortable road driving and site operations (6):

- rotate lever "C" to position "Z" to engage the longitudinal suspension
- rotate lever "C" to position "Y" to disengage the longitudinal suspension making the seat rigid.



WARNING! It is forbidden and it is extremely dangerous to adjust the driver's seat while the vehicle is moving. Position the driver's seat so that the driver can easily reach the vehicle controls.

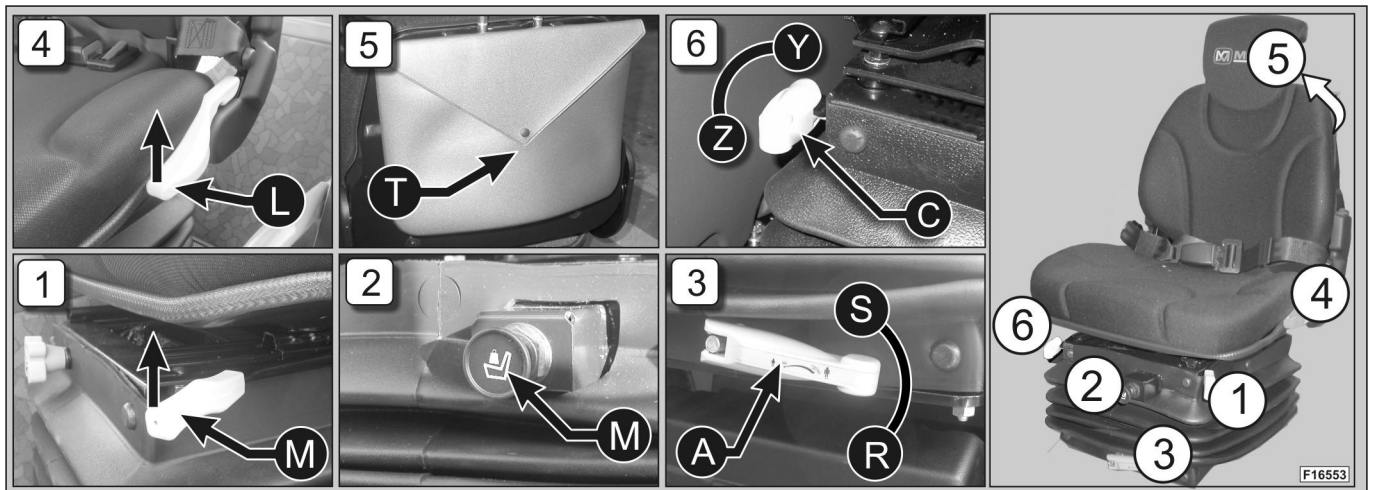



CONDITIONER

To properly cool the temperature of the driver's cabin, follow these instructions.

- Open all the cabin air vents
- After a long stop under the sun, let air into the driver's cabin by leaving all windows open for a few minutes and bringing ventilation control (36) on the second speed (for further information, refer to paragraph "HEATING" in chapter "CONTROLS AND INSTRUMENTS").
- Make sure that heating control (35) is on position "C"; otherwise, rotate the handle so as to close the heating tap.
- To always ensure the air-conditioning maximum reliability and efficiency, it is recommended to regularly clean the condensator. This component is located in the high spoiler under the driver's cabin.
- Should the air-conditioning efficiency deteriorate, have the coolant quantity checked by qualified and skilled personnel.

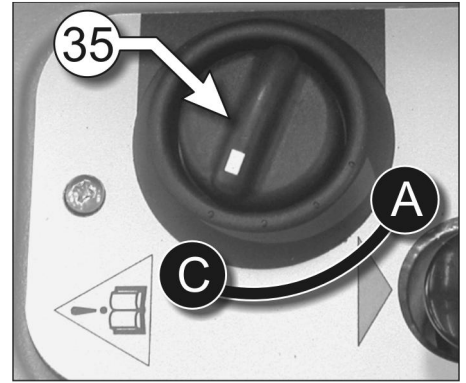

COMPONENTS

- handle (35) in position "A": heating on
- handle (35) in position "C": heating off
- selector "A" in position "0": air-conditioning off
- selector "A" in position "1": air-conditioning on
- selector (36) in position "0": ventilation off (do not use when selector "A" is on position "1")
- selector (36) in position "1": ventilation on - first speed
- selector (36) in position "2": ventilation on - second speed

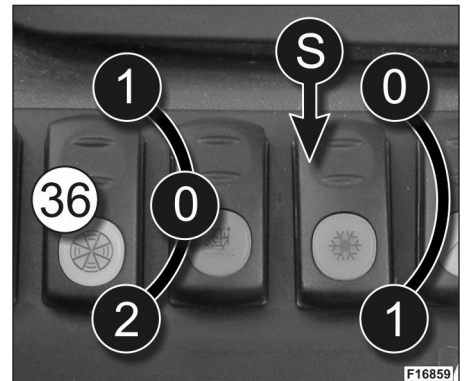

OPERATING INSTRUCTIONS

To properly activate air-conditioner "A" follow these instructions:

- Bring handle (35) to position "C"
- Bring selector (36) to position "1" or "2"
- Rotate selector "A" to position "1"



WARNING! Do not activate air-conditioner "A" if the ventilator control (36) is in position "0", as this would dramatically reduce the system performance and may generate ice on the evaporator. Any water leakage under the vehicle is due to the normal discharge of the condensation produced by the air conditioner dehumidifying effect.

END OF CHAPTER



INDEX

HYDROSTATIC TRANSMISSION CIRCUIT 2

HYDRAULIC SYSTEM..... 4

END OF CHAPTER 5



HYDROSTATIC TRANSMISSION CIRCUIT

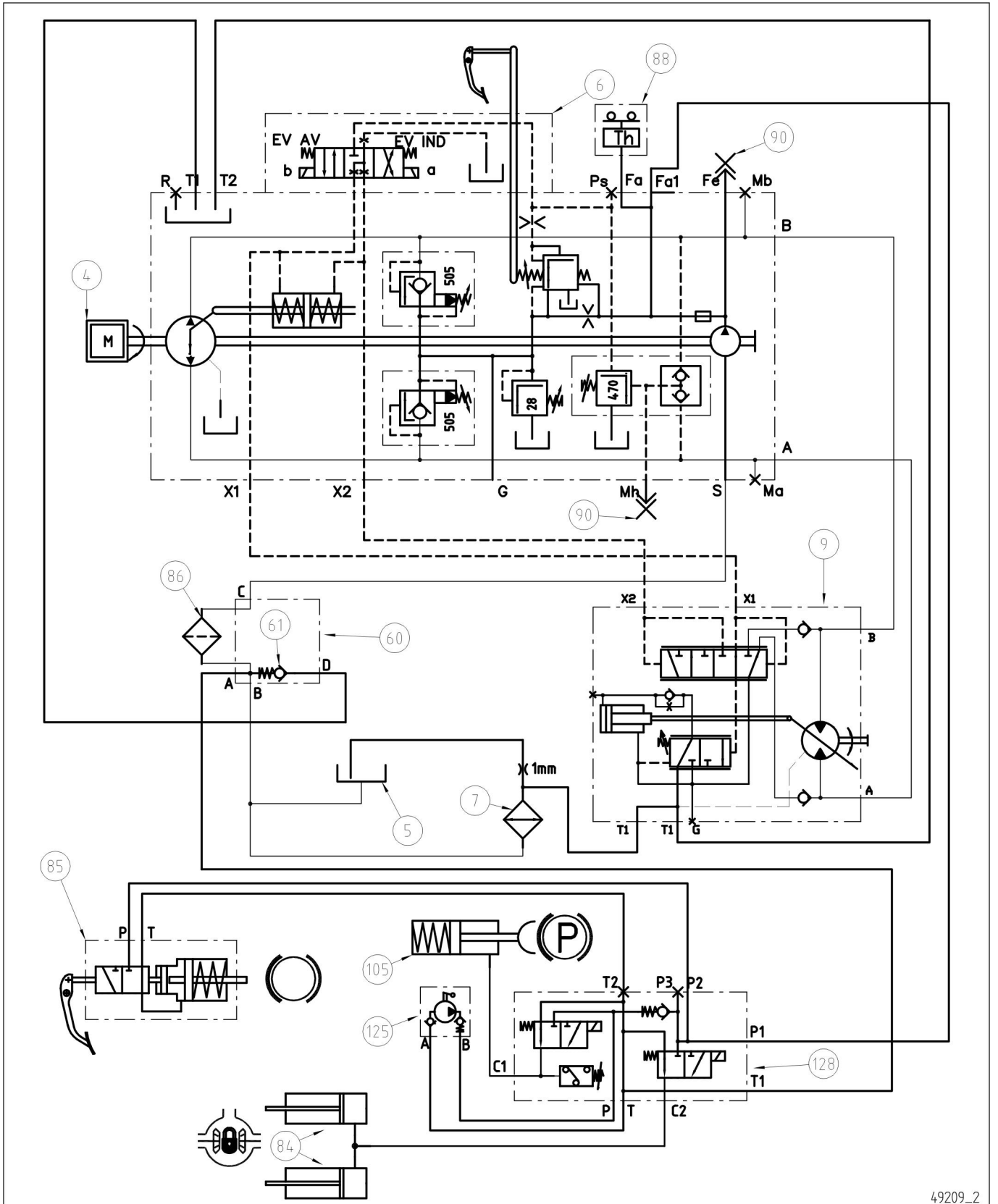

49209_2



<i>REFERENCE</i>	<i>DESCRIPTION</i>
4	Diesel engine
5	Tank for hydrostatic oil
6	Hydrostatic pump, variable delivery type
7	Heat exchanger
9	Hydrostatic motor, variable displacement
60	Filter carrying block
61	Bypass
84	Rams for differential-lock (OPTIONAL)
85	Servo/brake (OPTIONAL)
86	Cartridge filter
88	Thermal contact
90	Pressure tube
105	Parking brake caliper
125	Emergency pump
128	Solenoid valve block



HYDRAULIC SYSTEM

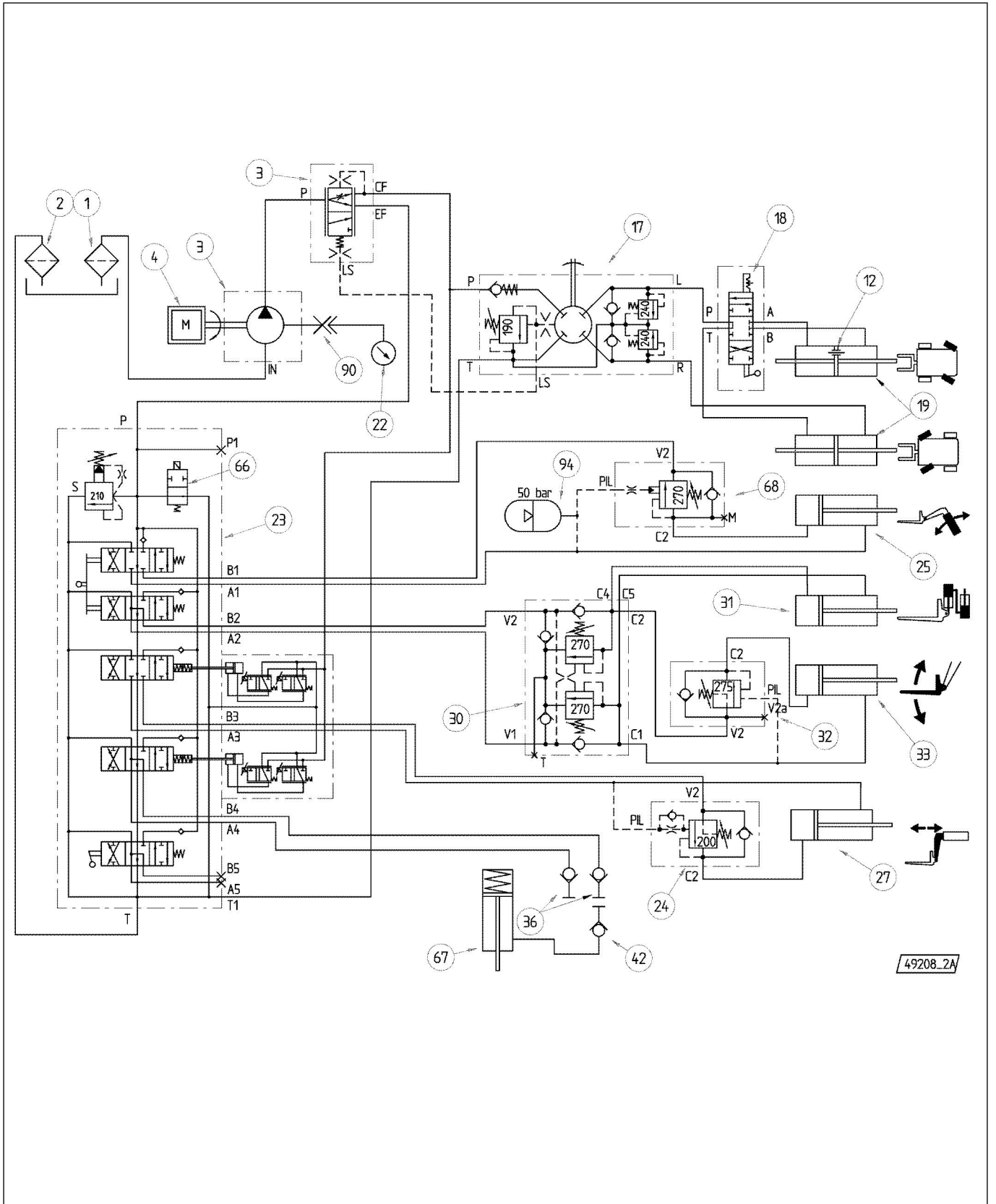



<i>REFERENCE</i>	<i>DESCRIPTION</i>
1	Intake filter
2	Return filter
3	Pump
4	Diesel engine
12	Volume recovery valve
16	Priority valve
17	Hydraulic power steering
18	Steering control valve
19	Steering cylinders
22	Pressure gauge
23	Main control valve
24	Lock valve for the boom extension cylinder
25	Lift cylinder
27	Boom extension cylinder
30	Forks/compensation valve
31	Compensation cylinder
32	Lock valve for fork cylinder
33	Fork cylinder
36	Front quick couplings, Ø 1/2"
42	Quick coupling, Ø 1/2"
66	Solenoid valve for movement release
67	Quick release cylinder
68	Lock valve for the boom extension cylinder
90	Pressure tap
94	Accumulator

127 - P3 (T2) = Reference to part. n° 127 connection P3 (T2) hydrostatic transmission circuit.

END OF CHAPTER



INDEX

GENERAL FEATURES.....2

BATTERY2

FUSES.....4

END OF CHAPTER5

**GENERAL FEATURES**

Your telescopic handler is equipped with a 12 volt electrical equipment with the negative pole grounded.

BATTERY

The battery of your machine is placed inside engine compartment and it is equipped with a manual cut-off switch that keeps it charged when the machine is not set in motion for a prolonged period of time.

NOMENCLATURE OF THE BATTERY COMPARTMENT:

- A) Battery
- B) Positive pole
- C) Negative pole
- D) Manual cut-off switch
- E) Main fuse of the electrical equipment (80A)
- F) Engine pre-heater fuse (80A)
- G) Glow plugs relay

The main features of the battery are listed below:

- Capacity in 20 hours = 100 Ah
- Cold start current = 850 A
- Specific weight: a fully charged battery shall have an electrolyte with a specific weight of 1.260. If this value is lower than 1.215, the battery needs to be charged.

The specific weight of the electrolyte may only be different if you work in countries having either a tropical climate or a cold climate.

In a tropical climate the readout for a fully charged battery shall be equal to 1.225.

In a cold climate the readout for a fully charged battery shall be equal to 1.280.

- Inspection of the electrical equipment: regularly check the condition of cable harnesses and electrical connections.

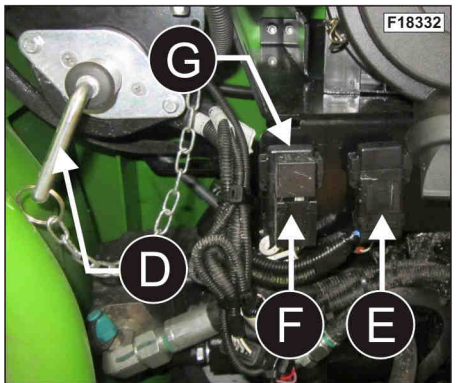
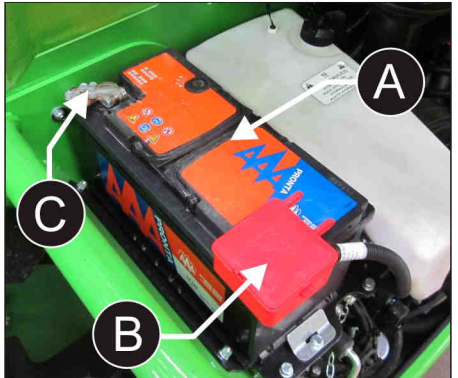

WARNING! All inductive loads (electric motors, solenoid valves, etc.) are protected by internal diodes in order to avoid current peaks when switched off, for this reason never swap the input polarities.

- sulphuric acid:



WARNING! Sulfuric acid in batteries is a poison and could cause severe burns. Avoid contact with skin, eyes, and clothes. When you work around batteries, protect eyes and face from battery fluid and explosion.

If you accidentally come into contact with the sulphuric acid contained in the battery, proceed as follows:

External measures:

- wash your skin with water
- rinse your eyes for 15 minutes
- seek immediate medical advice

Internal measures:

- drink plenty of water or milk
- soon afterwards drink milk of magnesia, beaten eggs, or vegetable oil
- seek immediate medical advice



IMPORTANT! Before carrying out any work on the electrical equipment disconnect the negative cable from the battery. The gases contained in the battery may explode. Keep cigarettes, sparks and flames away from the battery. Never use connection cables and never work on the connections if you are not familiar with the correct procedure to be followed.

When you either charge a battery or use a battery in an enclosed room, make sure that the room is well ventilated.

Keep batteries away from children.

Make sure that the vent plugs are tightened correctly, and check the electrolyte level at regular intervals.



MANUAL BATTERY CUT-OFF SWITCH

For greater safety, or when the machine is not set in motion for a prolonged period of time, it is possible to remove power from the electrical equipment of the machine via the manual battery cut-off switch.

1) Follow the instructions below to operate the battery cut-off switch:

- turn battery cut-off switch "D" to position "OFF"
- under these conditions it is no longer possible to start the engine.

2) Follow the instructions below to power the electrical equipment of the machine again:

- turn battery cut-off switch "D" to position "ON"
- under these conditions it is possible to start the engine again.

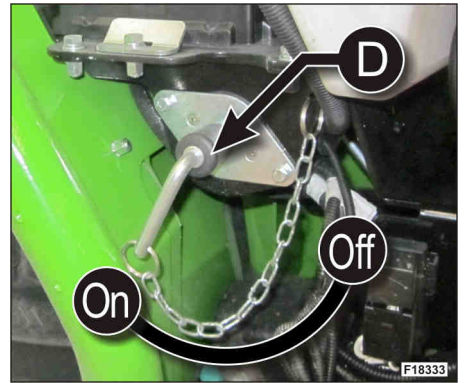

WARNING! Never use the battery cut-off switch when either the diesel engine is running or the instrument panel is switched on, since severe damage to the electrical equipment and to the instruments of your machine may occur. The battery cut-off switch is not intended as an engine shutdown device, and it shall not be used as such.

For a correct use of this switch, stop the diesel engine first, then take the engine start key out of the instrument panel, wait about 30 seconds and finally rotate selector "D" to "Off".

Should the previously described procedure not be followed, serious errors may occur in the electronic control unit.

**FUSES**

Electrical circuits are protected by fuses, situated in the panel "7" inside the cabin, and inside the engine compartment. If a fuse is blown, find what cause it to blow before replacing it with a new one having the same characteristics.

In the following part of the paragraph the several fuses of the standard machine are described. If optional accessories are ordered, the fuses relating to them are placed next to the main fuse.

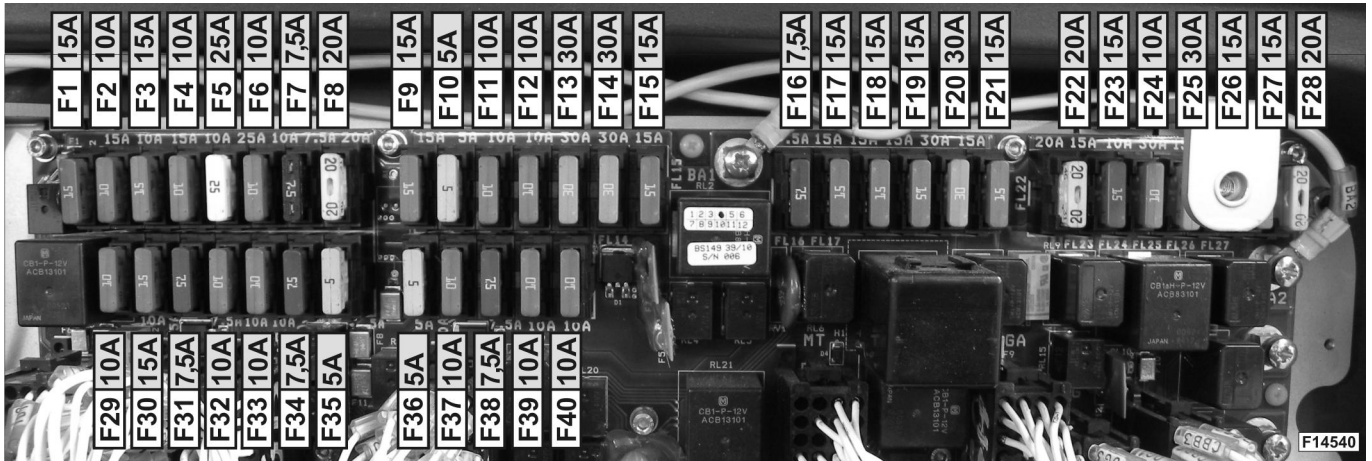

FUSE	AMPERAGE	USE
F1	15A	Power supply to optional equipment with ignition key in position "R" (instrument panel on)
F2	10A	Power supply to the PCB of the hydrostatic transmission
F3	15A	Power supply to the PCB for tilting and side shift control
F4	10A	Power supply to the PCB of the Tecnomat joystick
F5	25A	25A electric outlet (not available on this model)
F6	10A	Power supply to control panels (P) and (P1) with ignition key in position "R"
F7	7,5A	Solenoid valve for movement release (overturn prevention)
F8	20A	Power supply to the PCB for the rear 3-point linkage with ignition key in position "R" (instrument panel on) (not available on this model)
F9	15A	Rear window wiper, roof window wiper (available as an option), radio
F10	5A	Solenoid valves for movement release with operating mode selector (6) in emergency position "C"
F11	10A	Windscreen wiper, windscreen washing pump
F12	10A	Power supply to the accessories installed on the telescopic boom, power supply to the load limiter
F13	30A	Starter
F14	30A	Power supply to the diesel engine ECU (not available on this model)
F15	15A	Pneumatic seat (available as an option), optional equipment in the cab
F16	7,5A	Direct power supply to the PCB for the rear 3-point linkage (not available on this model)
F17	15A	High-beam headlights
F18	15A	Horn
F19	15A	Blinkers
F20	30A	Magnetic clutch of the condenser (available as an option), electric fan on the air conditioning condenser (available as an option)
F21	15A	Low-beam headlights
F22	20A	Heated seat (available as an option)
F23	15A	Boom-mounted work lights (available as an option)
F24	10A	Pneumatic braking system (available as an option)



F25	30A	Fan in the cab
F26	15A	Cab-mounted rear work lights
F27	15A	Cab-mounted front work lights
F28	20A	Cigar lighter, direct power supply from the battery cut-out switch
F29	10A	Engine stop solenoid valves
F30	15A	Power supply to the platform with simplified controls (available as an option)
F31	7,4A	Front left and rear right parking lights
F32	10A	Power supply to optional accessories
F33	10A	Stop lights
F34	7,5A	Front right and rear left parking lights, number plate light
F35	5A	Left blinker of the trailer
F36	5A	Right blinker of the trailer
F37	10A	Stop light of the trailer
F38	7,5	Tail lights of the trailer
F39	10A	Trailer-mounted rotary beacon light
F40	10A	Cab-mounted rotary beacon light

FUSES IN THE ENGINE COMPARTMENT

- 1) Main fuse (80A)
- 2) Engine pre-heater fuse (80A)

If optional accessories are ordered, the fuses relating to them are placed next to the main fuse.

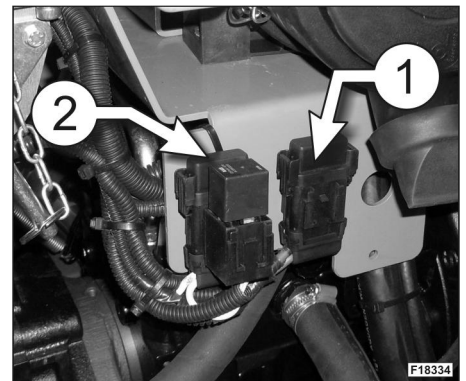

END OF CHAPTER

PUBLICATION DATE OF THIS MANUAL: May 2013



MERLO S.P.A. - CUNEO, ITALY			
<i>Plate of authorized attachments on P25.6</i>			
FIXED LOADS			
Standard forks	A0300	Digging bucket	A0699
FEM carriage + forks	A0200 + A0500	Digging bucket	A0700
Side-shift on carriage	A0282 + A0500	Re-handling bucket	A0713
Floating forks	A0291	4 in 1 bucket	A0810
Extralong forks	A0320	Multipurpose bucket	A0836
Fork extensions	A0600 on A0300	Drum clamp	A2210
Fork rotator	A3210		
Fork rotator	A3212		
FREELY SUSPENDED LOADS			
Crane hook on carriage	A1000	Fly Jib 400 kg	A1230B
Crane boom	A1114B_AU		
092476		AS1418.19 COMPLIANT	



P25.6 Load Chart - Fork extensions



THIS LOAD CHART REFERS ONLY TO MACHINES WITH M-CDC

Fork extensions REF.No A0600
on standard forks REF.No A0300
Maximum cap. 1200 kg

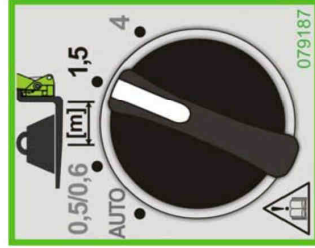
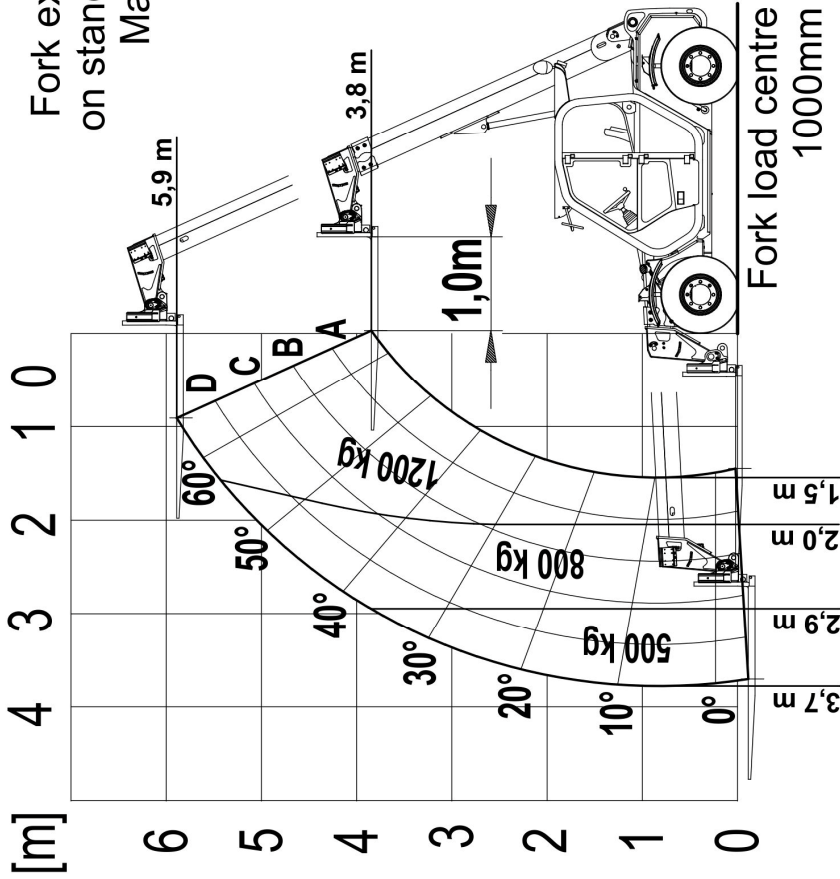

Standard used
AS1418.19

WARNING Load charts are different for each attachment fitted to the telehandler. Please ensure the attachment part number is as shown above.

Lifting (Stationary)

With rated load on forks
3° MAX

With rated load on forks
5° MAX

With rated load on forks
3° MAX

Pick & Carry (Travelling)

With rated load on forks
18° MAX

With rated load on forks
7° MAX

With rated load on forks
6° MAX

- Pick and Carry information
1. Travel speed with rated load 0.4 m/s (walking speed)
 2. Boom fully retracted
 3. Rated load no more than 300mm above the ground
 4. In-Service wind speed 10 m/s - 36 km/h
- Solid surfaces for both lifting and travelling.
Slope ratings listed in diagrams on the left for both configurations.

SAFE USE INFORMATION

Tyre manufacturer	Mitas	Chart Number	085414
Tyre size	12.0/75-18 12 pr	Revision Date	A
Tyre pressure	400 kPa (58 psi)		Febr. 2013



P25.6 Load Chart - Fork carriages

- FEM Carriage REF.No A0200 with FEM III fork REF.No A0500 Maximum cap. 1800 kg
- Floating forks carriage REF.No A0291 Maximum cap. 1800 kg

On models with M-CDC:

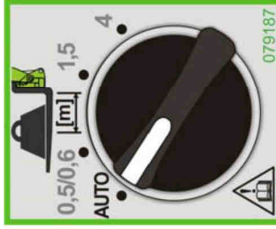

Standard used AS1418.19

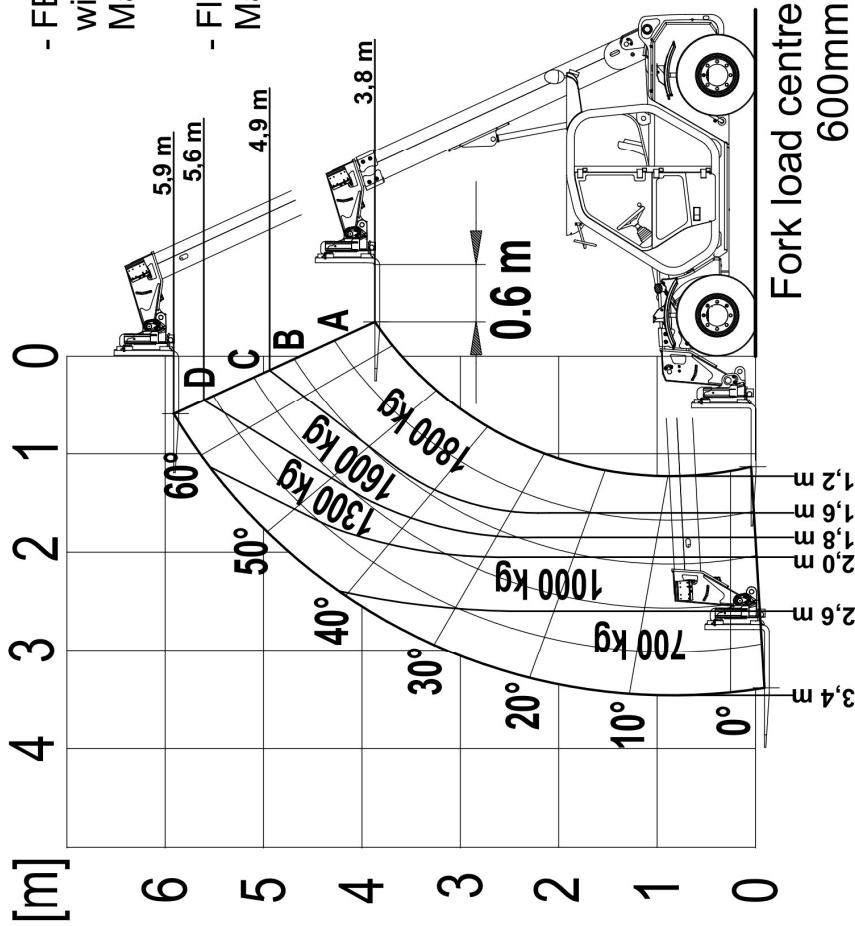

WARNING Load charts are different for each attachment fitted to the telehandler. Please ensure the attachment part number is as shown above.

- Pick and Carry information
1. Travel speed with rated load 0.4 m/s (walking speed)
 2. Boom fully retracted
 3. In-Service wind speed 10 m/s - 36 km/h
 4. Ground conditions
- Slope ratings listed in diagrams on the left for both configurations.

<p>Lifting (Stationary)</p> <p>With rated load on forks</p> <p>3° MAX</p>	<p>With rated load on forks</p> <p>5° MAX</p>	<p>With rated load on forks</p> <p>3° MAX</p>
<p>Pick & Carry (Travelling)</p> <p>With rated load on forks</p> <p>18° MAX</p>	<p>With rated load on forks</p> <p>7° MAX</p>	<p>With rated load on forks</p> <p>6° MAX</p>

SAFE USE INFORMATION

Chart Number	085413	
Revision Date	A	Febr. 2013

Tyre manufacturer	Mitas
Tyre size	12.0/75-18 12 pr
Tyre pressure	400 kPa (58 psi)



P25.6 Load Chart - Fork carriages

- FEM Carriage REF.No A0200 with FEM III fork REF.No A0500 Maximum cap. 1800 kg
- Floating forks carriage REF.No A0291 Maximum cap. 1800 kg

On models with M-CDC:

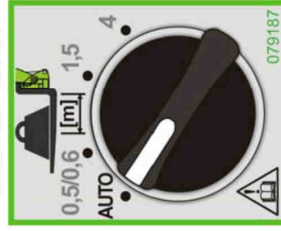

Standard used AS14.18.19

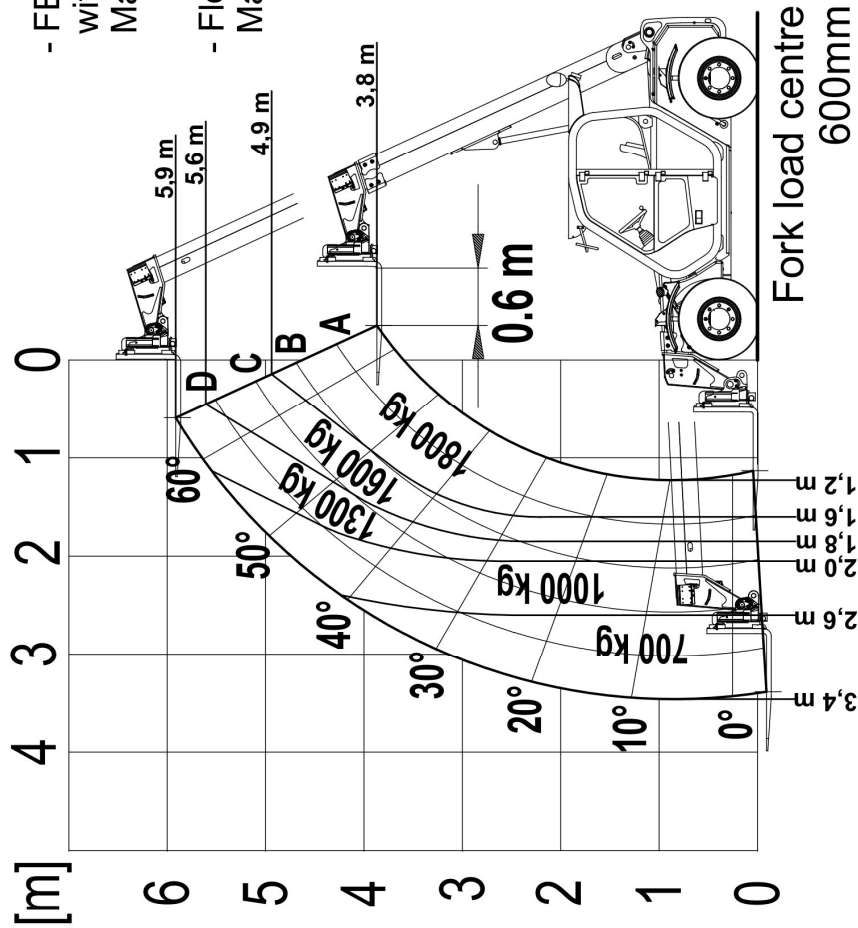

Fork load centre 600mm

WARNING Load charts are different for each attachment fitted to the telehandler. Please ensure the attachment part number is as shown above.

- Pick and Carry information
1. Travel speed with rated load 0.4 m/s (walking speed)
 2. Boom fully retracted
 3. Rated load no more than 300mm above the ground
 4. In-Service wind speed 10 m/s - 36 km/h
- Ground conditions
Solid surfaces for both lifting and travelling.
Slope ratings listed in diagrams on the left for both configurations.

Lifting (Stationary)

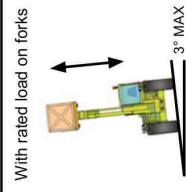
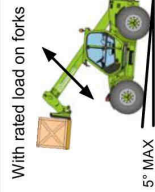
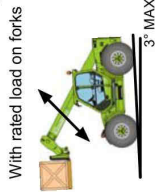

Pick & Carry (Travelling)

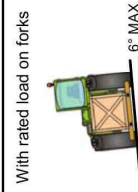
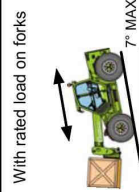
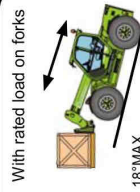

SAFE USE INFORMATION

Chart Number		085413	
Tyre manufacturer		Mitas	
Tyre size		12.0/75-18 12 pr	
Tyre pressure		400 kPa (58 psi)	
Revision Date		A Febr. 2013	



P25.6 Load Chart - Buckets



Table of applicable buckets

Category	Digging	Digging	Re-handling	4-in1	Multip.
REF No.	A0699	A0700	A0713	A0810	A0836
Max cap.	550 L	800 L	1700 L	600 L	700 L
Weight	260 kg	370 kg	440 kg	590 kg	500 kg
a	1235 kg	1800 kg	1530 kg	1200 kg	1540 kg
b	1235 kg	1500 kg	1450 kg	1200 kg	1400 kg
c	1235 kg	1250 kg	1200 kg	1050 kg	1150 kg
d	1150 kg	1000 kg	950 kg	800 kg	900 kg
e	800 kg	650 kg	600 kg	450 kg	550 kg
Not permitted zone					

On models with M-CDC:

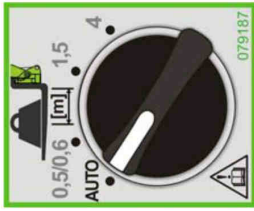

The bucket in the load chart is just an example

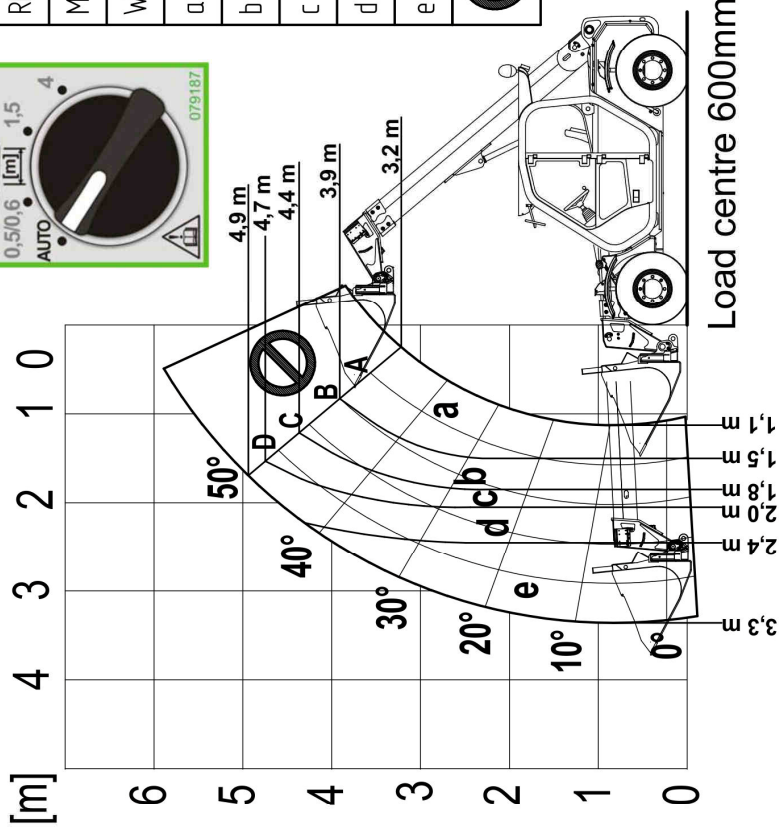

Standard used
AS1418.19



WARNING Load charts are different for each attachment fitted to the telehandler. Please ensure the attachment part number is as shown above.

- Pick and Carry information
- Travel speed with rated load 0.4 m/s (walking speed)
 - Boom fully retracted
 - Rated load no more than 300mm above the ground
 - In-Service wind speed 10 m/s - 36 km/h
- Ground conditions
Solid surfaces for both lifting and travelling.
Slope ratings listed in diagrams on the left for both configurations.

SAFE USE INFORMATION

Chart Number	085415
Revision Date	A Febr. 2013

Tyre manufacturer	Mitas
Tyre size	12.0/75-18 12 pr
Tyre pressure	400 kPa (58 psi)

Lifting (Stationary)

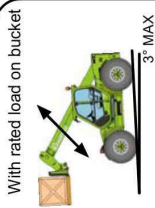

Lifting (Travelling)

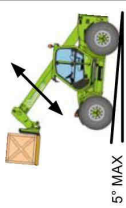

Pick & Carry (Stationary)

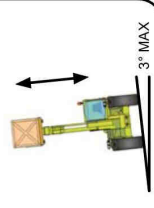

Pick & Carry (Travelling)

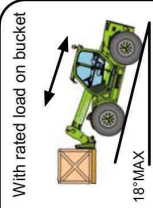

Lifting (Stationary)

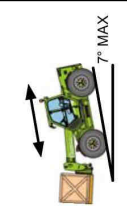

Lifting (Travelling)

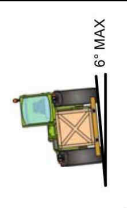



P25.6 Load Chart - Crane hook on carriage

Crane hook on carriage REF.No A1000
Maximum cap. 2500 kg

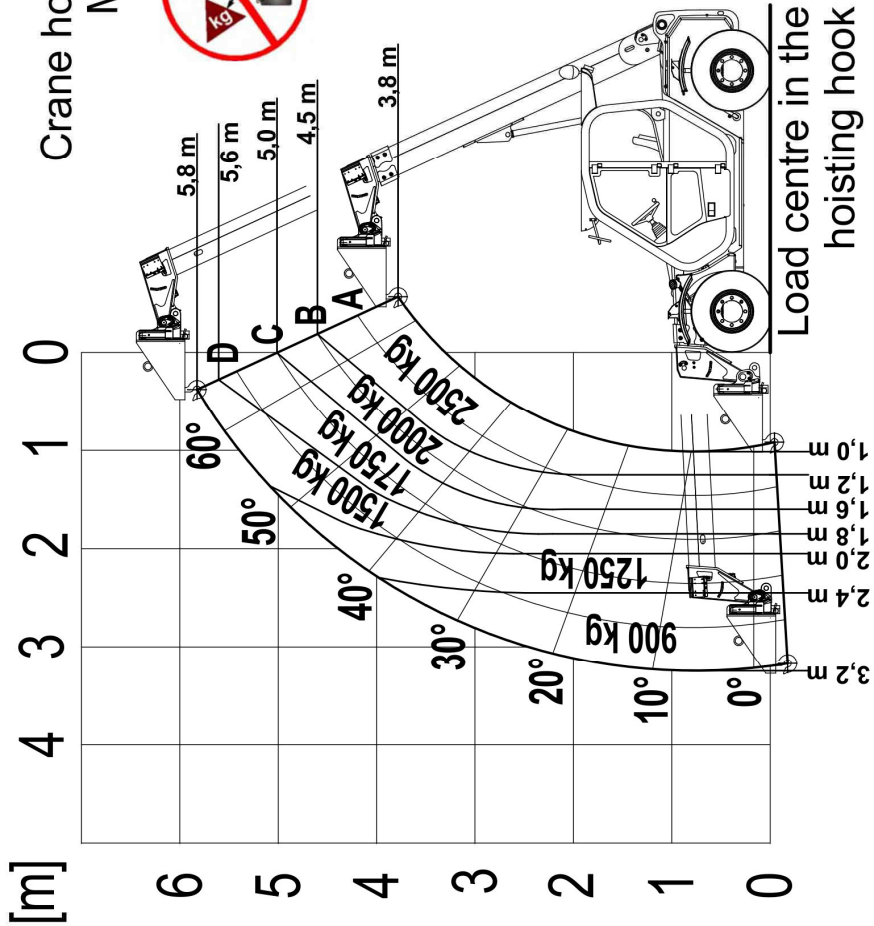

WARNING
Always operate with the crane hook perfectly level



On models with M-CDC:



Standard used
AS14.18.19

Load centre in the hoisting hook

WARNING Load charts are different for each attachment fitted to the telehandler. Please ensure the attachment part number is as shown above.

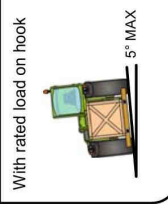
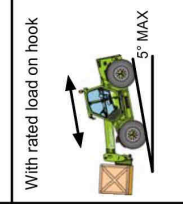
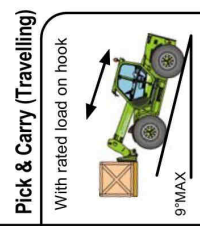
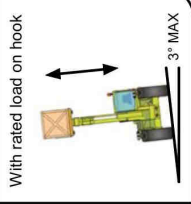
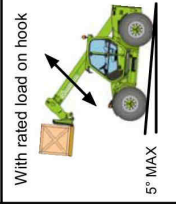
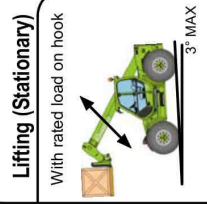

- Pick and Carry information**
1. Travel speed with rated load 0.4 m/s (walking speed)
 2. Boom fully retracted and boom angle lower than 50°
 3. Rated load no more than 300mm above the ground
 4. In-Service wind speed 10 m/s - 36 km/h
- Solid surfaces for both lifting and travelling.
Slope ratings listed in diagrams on the left for both configurations.

SAFE USE INFORMATION

Chart Number		085416	
Tyre manufacturer		Mitas	
Tyre size		12.0/75-18 12 pr	
Tyre pressure		400 kPa (58 psi)	
Revision Date		A	Febr. 2013

P25.6 Load Chart - Crane boom



Reduced height crane boom REF.No A1114B_AU
Maximum cap. 1250 kg

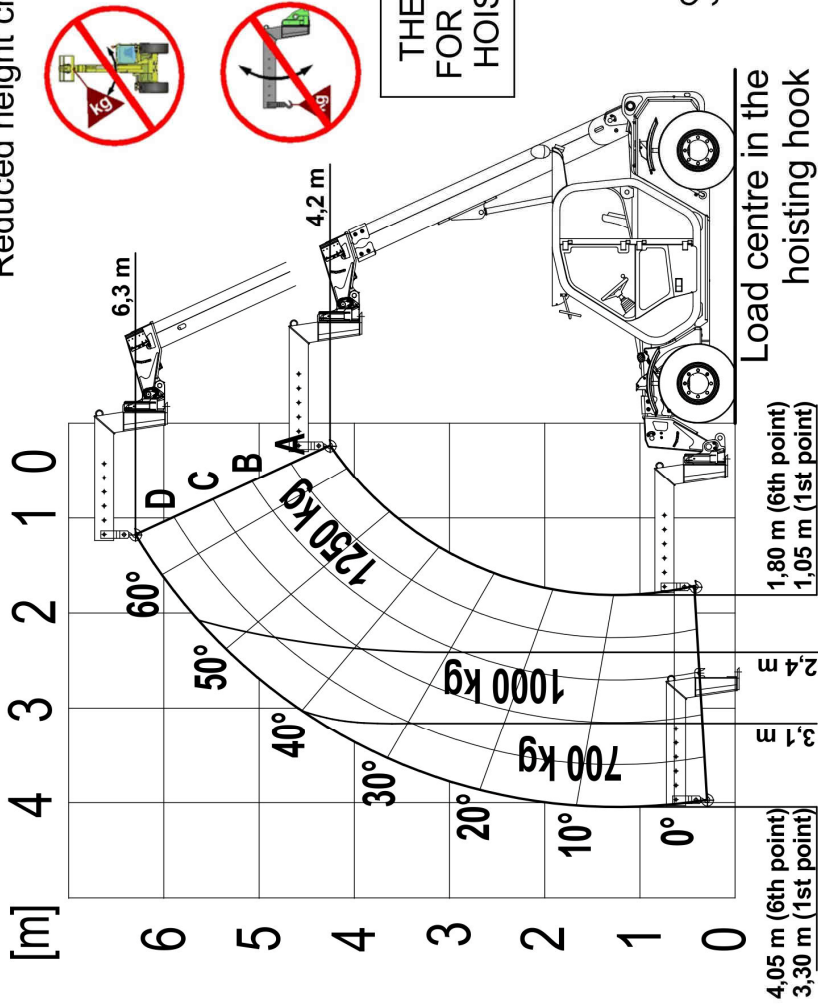

Lifting (Stationary)

With rated load on hook

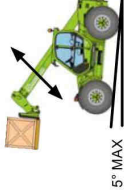

3° MAX

With rated load on hook



5° MAX

With rated load on hook

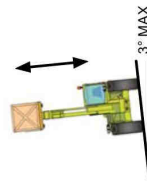

3° MAX

Pick & Carry (Travelling)

With rated load on hook

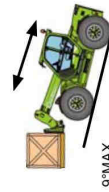

9° MAX

With rated load on hook

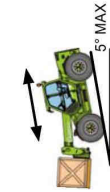

5° MAX

With rated load on hook

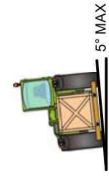

5° MAX

WARNING

Always check the right locking for the hook holder support



WARNING

Always operate with the crane boom perfectly level

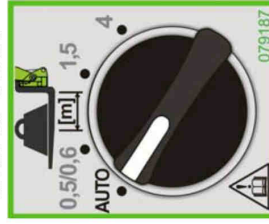

THE LOAD CHART IS THE SAME FOR EVERY POINT IN WHICH THE HOISTING HOOK IS POSITIONED

On models with M-CDC:



Standard used AS14:18.19

Load centre in the hoisting hook

4,05 m (6th point)
3,30 m (1st point)
1,80 m (6th point)
1,05 m (1st point)

WARNING Load charts are different for each attachment fitted to the telehandler. Please ensure the attachment part number is as shown above.

Pick and Carry information

1. Travel speed with rated load 0.4 m/s (walking speed)
2. Boom fully retracted and boom angle lower than 50°
3. Rated load no more than 300mm above the ground
3. In-Service wind speed 10 m/s - 36 km/h
4. Ground conditions

Solid surfaces for both lifting and travelling.

Slope ratings listed in diagrams on the left for both configurations.

SAFE USE INFORMATION

Chart Number	085417	
Tyre manufacturer	Mitas	Revision Date
Tyre size	12.0/75-18 12 pr	A
Tyre pressure	400 kPa (58 psi)	Febr. 2013



P25.6 Load Chart Fly Jib

Fly-Jib REF.No A1230B
Maximum cap. 400 kg

On models
with M-CDC:

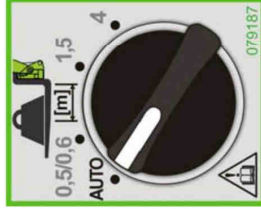

Standard used
AS14.18.19

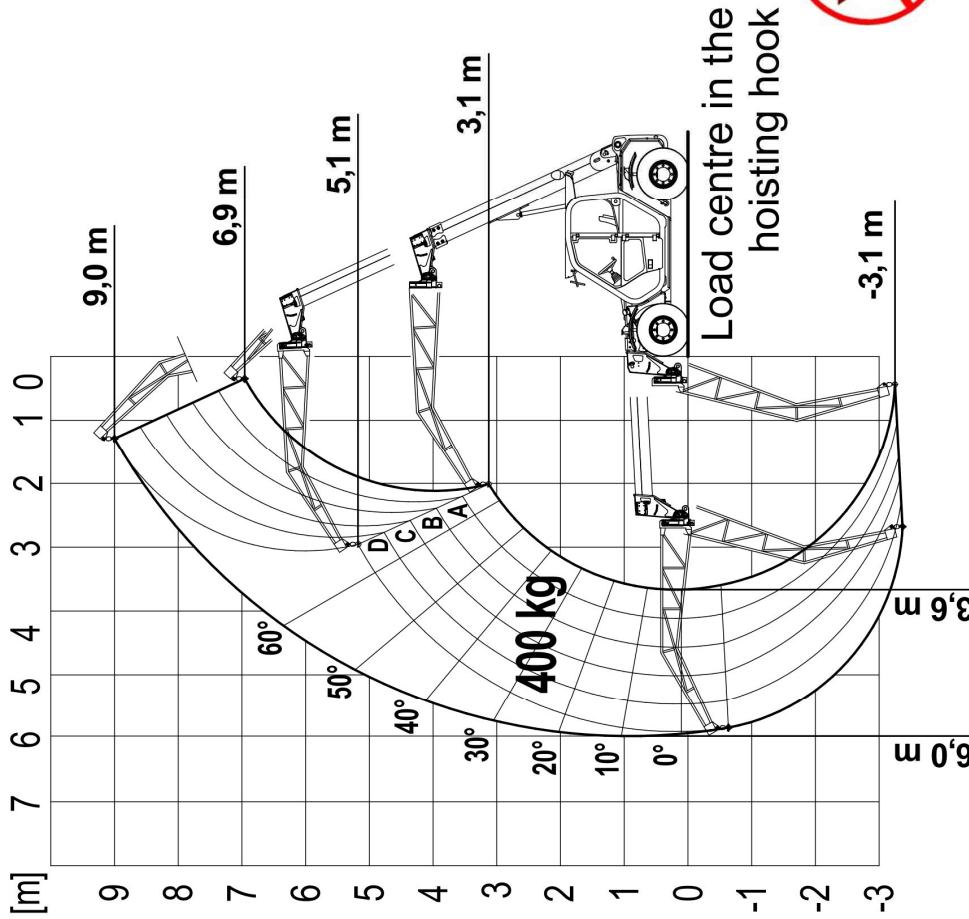

WARNING Load charts are different for each attachment fitted to the telehandler. Please ensure the attachment part number is as shown above.

Lifting (Stationary)

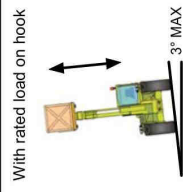
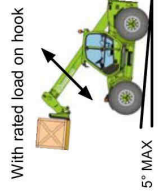
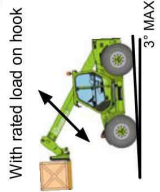

Pick & Carry (Travelling)

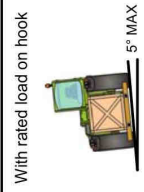
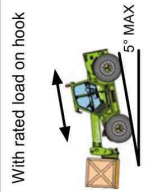
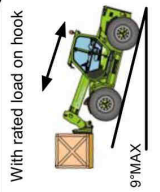

SAFE USE INFORMATION

- Pick and Carry information
1. Travel speed with rated load 0.4 m/s (walking speed)
 2. Boom fully retracted and boom angle lower than 50°
- Rated load no more than 300mm above the ground
- Horizontal Fly-Jib
3. In-Service wind speed 10 m/s - 36 km/h
 4. Ground conditions
- Solid surfaces for both lifting and travelling.
Slope ratings listed in diagrams on the left for both configurations.

Chart Number	085418
Revision Date	A Febr. 2013

Tyre manufacturer	Mitas
Tyre size	12.0/75-18 12 pr
Tyre pressure	400 kPa (58 psi)



P25.6 Load Chart - Drum clamp

Drum Clamp
REF.No A2210

Drum diameter from 600 mm to 700 mm
Max cap. 600 kg

On models
with M-CDC:

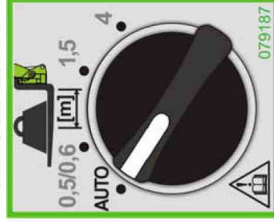

Standard used
AS14.18.19

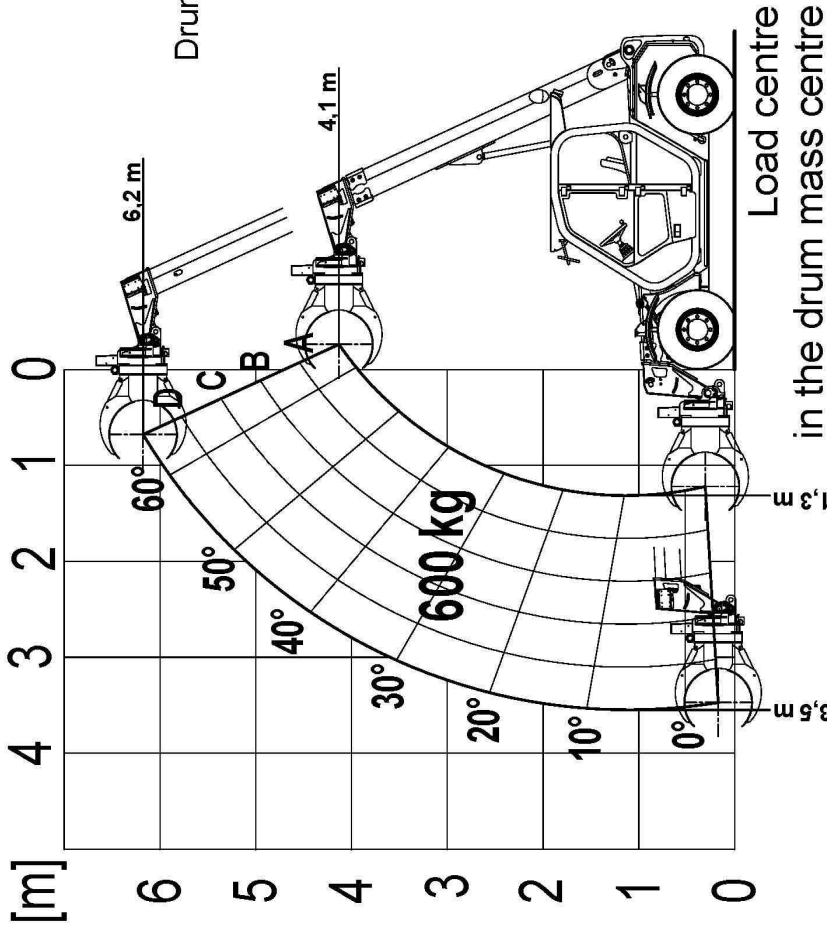

WARNING Load charts are different for each attachment fitted to the telehandler. Please ensure the attachment part number is as shown above.

<p>Lifting (Stationary) With rated load on clamp</p> <p>3° MAX</p>	<p>With rated load on clamp</p> <p>5° MAX</p>	<p>With rated load on clamp</p> <p>3° MAX</p>	<p>Pick & Carry (Travelling) With rated load on clamp</p> <p>18° MAX</p>	<p>With rated load on clamp</p> <p>7° MAX</p>	<p>With rated load on clamp</p> <p>8° MAX</p>
---	---	---	---	---	---

- Pick and Carry information**
- Travel speed with rated load 0.4 m/s (walking speed)
 - Boom fully retracted
 - Rated load no more than 300mm above the ground
 - In-Service wind speed 10 m/s - 36 km/h
- Ground conditions
Solid surfaces for both lifting and travelling.
Slope ratings listed in diagrams on the left for both configurations.

SAFE USE INFORMATION

Chart Number	087251	
Revision Date	A	Oct. 2013
Tyre manufacturer	Mitas	
Tyre size	12.0/75-18 12 pr	
Tyre pressure	400 kPa (58 psi)	



P25.6 Load Chart - Extra-long forks

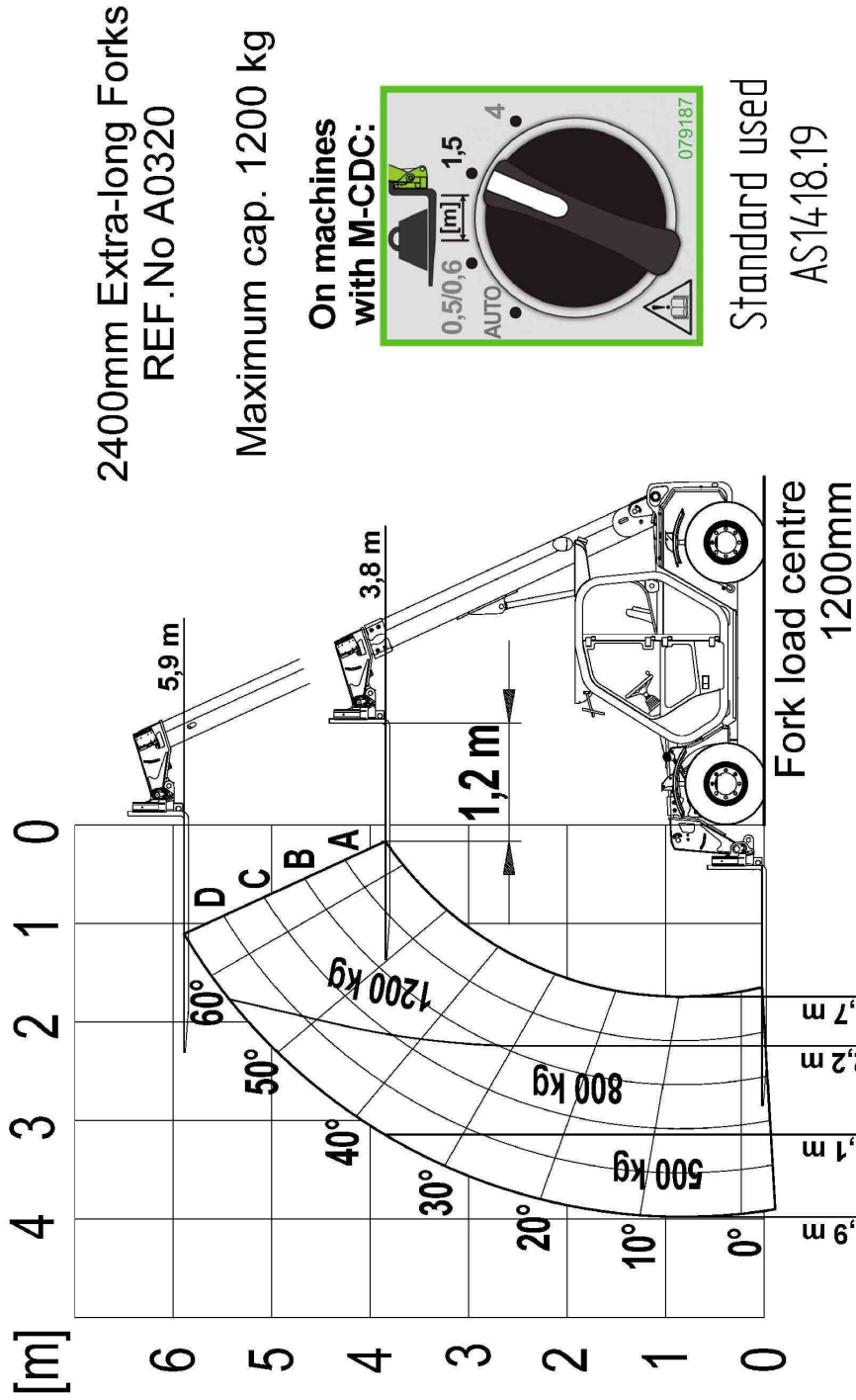

<p>Lifting (Stationary)</p> <p>With rated load on forks</p> <p>3' MAX</p>	<p>With rated load on forks</p> <p>5' MAX</p>	<p>With rated load on forks</p> <p>3' MAX</p>
<p>Pick & Carry (Travelling)</p> <p>With rated load on forks</p> <p>18' MAX</p>	<p>With rated load on forks</p> <p>7' MAX</p>	<p>With rated load on forks</p> <p>6' MAX</p>

WARNING Load charts are different for each attachment fitted to the telehandler. Please ensure the attachment part number is as shown above.

- Pick and Carry information
- Travel speed with rated load 0.4 m/s (walking speed)
 - Boom fully retracted
 - Rated load no more than 300mm above the ground
 - In-Service wind speed 10 m/s - 36 km/h
- Ground conditions
Solid surfaces for both lifting and travelling.
Slope ratings listed in diagrams on the left for both configurations.

SAFE USE INFORMATION

Chart Number		090546	
Tyre manufacturer	Mitas	Revision Date	A July 2014
Tyre size	12.0/75-18 12 pr		
Tyre pressure	400 kPa (58 psi)		



P25.6 Load Chart - Fork Rotators



On models with M-CDC:

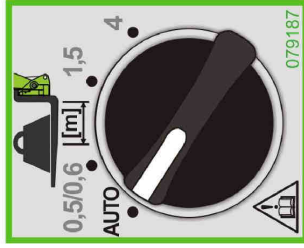

- Fork Rotator (Bolzoni based) REF No **A3212**

- Fork Rotator (Merlo original) REF No **A3210**

Max cap. 1600 kg

Use of a SKIP BINS:

1. Use SKIP BINS with a maximum height of 1,2 m (and/or not filled more than 1,2 m)
2. Use SKIP BINS with a maximum base width of 1,8 m
3. Move the boom with horizontal and full SKIP BIN
4. Rotate the SKIP BIN with stationary machine and boom

Standard used AS1418.19

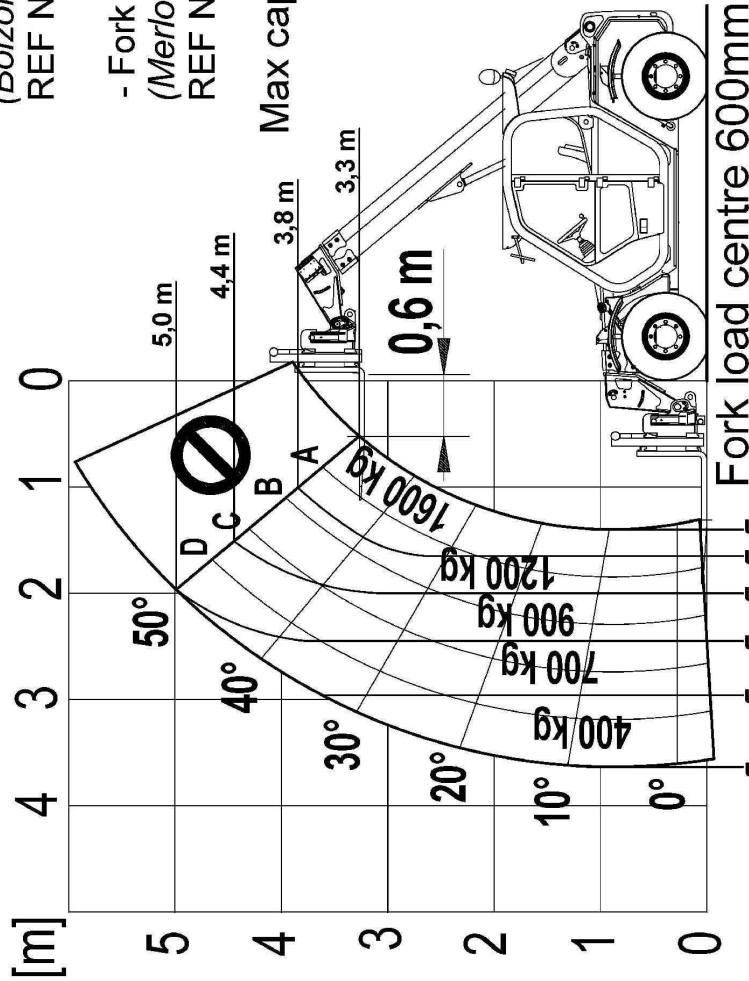

Fork load centre 600mm

Lifting (Stationary)

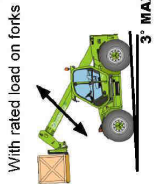

Pick & Carry (Travelling)



Lifting (Stationary)

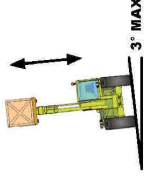

Pick & Carry (Travelling)

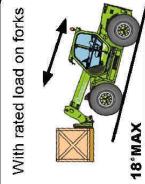

Lifting (Stationary)

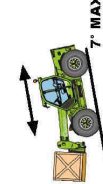

Lifting (Stationary)

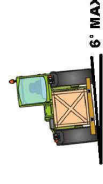

WARNING Load charts are different for each attachment fitted to the telehandler. Please ensure the attachment part number is as shown above.

- Pick and Carry information
1. Travel speed with rated load 0.4 m/s (walking speed)
 2. Boom fully retracted
 3. In-Service wind speed 10 m/s - 36 km/h
 4. Ground conditions
- Solid surfaces for both lifting and travelling.
Slope ratings listed in diagrams on the left for both configurations.

SAFE USE INFORMATION

Chart Number	091580	
Revision Date	A	July 2014

Tyre manufacturer	Mitas
Tyre size	12.0/75-18 12 pr
Tyre pressure	400 kPa (58 psi)



P25.6 Load Chart - Side-shift on carriage

Side-shift on carriage REF.No A0282
+ FEM III fork REF No A0500

Maximum cap. 1600 kg

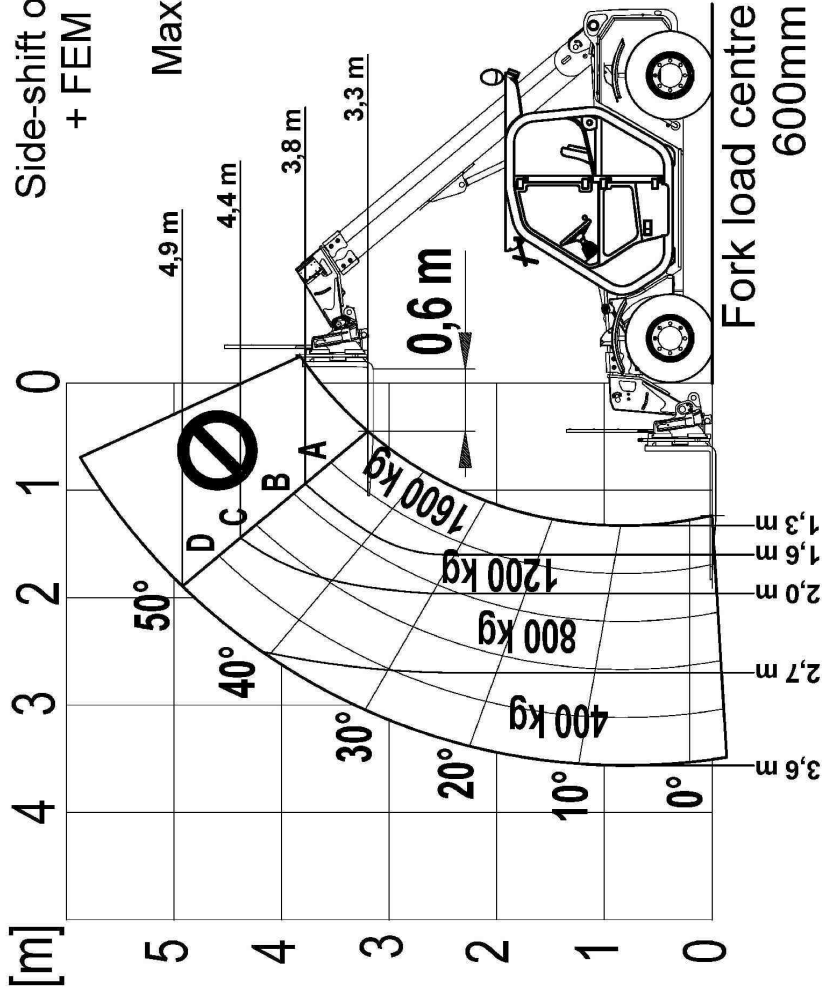

On models with M-CDC:

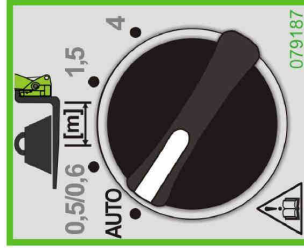

Standard used
AS14-18.19

WARNING Load charts are different for each attachment fitted to the telehandler. Please ensure the attachment part number is as shown above.

Pick and Carry information

1. Travel speed with rated load 0.4 m/s (walking speed)
 2. Boom fully retracted
 3. In-Service wind speed 10 m/s - 36 km/h
 4. Ground conditions
- Solid surfaces for both lifting and travelling.
Slope ratings listed in diagrams on the left for both configurations.

<p>Lifting (Stationary)</p> <p>With rated load on forks</p> <p>3' MAX</p>	<p>With rated load on forks</p> <p>5' MAX</p>	<p>With rated load on forks</p> <p>3' MAX</p>
<p>Pick & Carry (Travelling)</p> <p>With rated load on forks</p> <p>18' MAX</p>	<p>With rated load on forks</p> <p>7' MAX</p>	<p>With rated load on forks</p> <p>6' MAX</p>

SAFE USE INFORMATION

Chart Number	092444	
Revision Date	A	July 2014

Tyre manufacturer	Mitas
Tyre size	12,0/75-18 12 pr
Tyre pressure	400 kPa (58 psi)





MODULE

M3

**ATTACHMENTS FOR
MERLO ZM2
CARRIAGE**





INTRODUCTION

APPROVED ATTACHMENTS



WARNING!



RISK OF ACCIDENTS!

DO NOT use attachments that are not approved by MERLO for this machine.

The **APPROVED ATTACHMENTS** for this machine are exclusively the TREEMME attachments for which MERLO has supplied the load chart for the **machine / attachment combination** in the CHART DOSSIER CONTAINER (2) in the cab and in **MODULE 2 - CHART DOSSIER**.

DO NOT modify the attachments and **DO NOT use it** for purposes other than those envisaged in the relative user instructions.



WARNING



PLATFORM INSTRUCTIONS.

This manual **does not include** use with the TREEMME overhead working platform: for this attachment, refer to the **relative Operator Manual**.



FORKS	1
INSTALLATION	1
DE-INSTALLATION	2
FORKS LIST	3
ATTACHMENTS	5
ATTACHMENTS RELEASED IN THE EUROPEAN ECONOMIC AREA (EEA)	5
CONTENT OF THE EC DECLARATION OF CONFORMITY	5
EC DECLARATION OF CONFORMITY OF THE CABLES	5
ATTACHMENT IDENTIFICATION	6
PRELIMINARY CHECKS	6
MAINTENANCE	6
ATTACHMENT LIFTING	6
INSTALLATION	7
OPERATION OF THE QUICK-COUPLING CYLINDER (P)	7
MECHANICAL COUPLING.....	8
HYDRAULIC CONNECTION	9
ELECTRICAL CONNECTION.....	9
ATTACHMENT CONTROL.....	9
DE-INSTALLATION	10
ATTACHMENTS FOR FIXED LOADS	12
ADDITIONAL CARRIAGES WITH FORKS.....	12
LOADERS	22
FORKS WITH TINES.....	31
GRIPPERS.....	36
OTHER ATTACHMENTS.....	40
ATTACHMENTS FOR SUSPENDED LOADS	48
CARRIAGE-MOUNTED HOOK [A1000]	49
LIFTING BOOM [A1118B]	50
TELESCOPIC LIFTING BOOM [A1123B]	51

FLY JIB [A1200B A1210B A1230B].....	52
FLY JIB WITH WINCH [A1300B A1310B A1330B A1215B]	55
CARRIAGE-MOUNTED WINCH LIFT/SW [A2765].....	58
PLATFORMS	61

INSTALLATION



WARNING!



RISK OF ACCIDENTS!

Space the forks **evenly** before handling a load.

DO NOT lift loads with only one fork.

DO NOT handle overhead loads with the forks.

DO NOT install additional forks or other attachments on the carriage at the same time as the forks.

DO NOT request the help of another operator for the hooking or locking of the forks.

- ▶ Position the forks parallel on the ground.
- ▶ Driving the machine close to the forks.
- ▶ Engage the parking brake (37).
- ▶ Position the gear selector (19) and the direction selector (20) in neutral "N".
- ▶ Rotate the carriage downwards.
- ▶ Extend the boom almost as far as the attachment's couplings.
- ▶ Lift the boom and at the same time turn the carriage upwards until the carriage hooks the forks
- ▶ Lift the forks a few centimetres off the ground.
- ▶ Get down from the cab and close the cab door.

- ▶ **VISUALLY** verify that the locking devices (B) of the forks [Figure 4] are **properly lowered** to prevent the possible accidental release of the fork: otherwise, act on the locking device (B) from the outside and move it **manually** to the locking position.

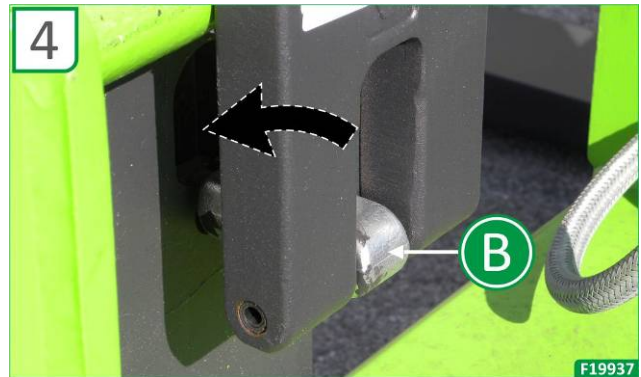

WARNING!



RISK OF ACCIDENTS!

DO NOT use the forks if both locking devices (B) are not fully lowered: otherwise, lower the boom and **repeat the hooking procedure**.

- ▶ **Insert** the supplied lateral locking devices (C) to **prevent the lateral sliding** of the forks.

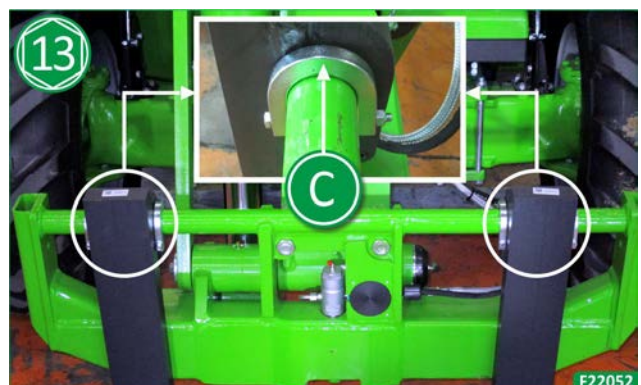

DE-INSTALLATION

**WARNING!****RISK OF ACCIDENTS!**

DO NOT request the help of another operator for the unhooking or release of the forks.

- ▶ Drive the machine into the **unhooking point of the forks**, with the boom fully retracted and lowered and the carriage upright.
- ▶ Make sure that the unhooking point of the forks is suitable to support the weight (see the following chapter).
- ▶ Press and hold down the service brake (15).
- ▶ Position the gear selector (19) and the direction selector (20) in neutral "N".
- ▶ Engage the parking brake (37).
- ▶ Disengage the service brake (15).
- ▶ Lower the boom to rest the attachment **on the ground**.
- ▶ Get down from the cab and **close the cab door**.
- ▶ Remove the lateral restraining devices (C) and put them in the glove compartment in the cab.

- ▶ Lift the **locking device (B)** of each fork [Figure 6] in the vertical position.

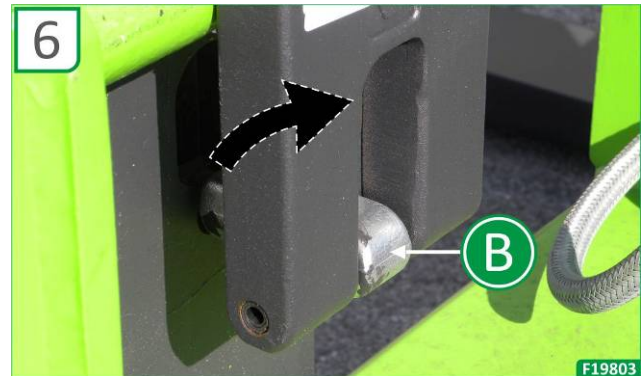

- ▶ Return to the cab, **fasten the seat belt** and close the door or the lower section of the door.
- ▶ Using the controls on the **joystick (1)**, lower the boom and at the same time turn the carriage downwards until releasing the carriage from the fork couplings.



FORKS LIST

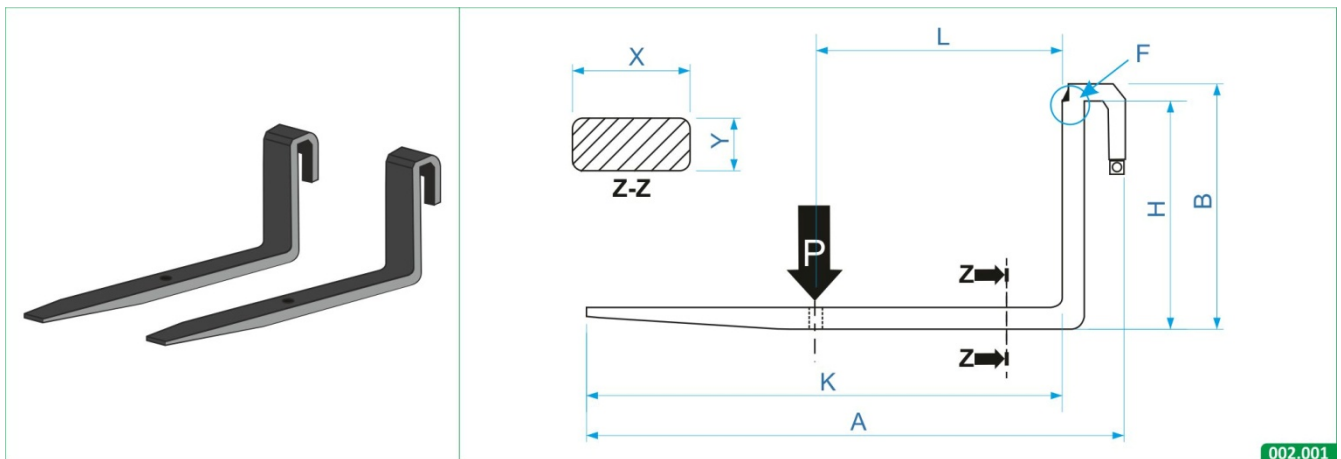

REF.	A0300		A0301		A0303		A0304	
SERIAL No.	050939		050941		050940		050942	
	kg	lb	kg	lb	kg	lb	kg	lb
WEIGHT	77	170	85	188	87	192	87	192
CAPACITY	1750	3860	2250	4970	1750	3860	2250	4970
	mm	in	mm	in	mm	in	mm	in
K	1200	47	1200	47	1200	47	1200	47
A	1327	52	1331	52	1327	52	1331	52
B	615	24	620	24	715	28	670	26
X	125	5	125	5	125	5	125	5
Y	45	2	50	2	45	2	50	2
H	555	22	560	22	655	26	610	24
L	500	20	500	20	500	20	500	20
F	1750 x 500		2250 x 500		1750 x 500		2250 x 500	



ATTACHMENTS RELEASED IN THE EUROPEAN ECONOMIC AREA (EEA)

CONTENT OF THE EC DECLARATION OF CONFORMITY

1	MERLO s.p.a. Via Nazionale, 9 - 12010 S. Defendente di Cervasca (CN) - IT	
2	representative of:	
3	TREEMME TECHNOLOGY s.r.l. Via Passatore, 2/a - 12010 S. Defendente di Cervasca (CN) - IT	
4	declares that the TREEMME interchangeable attachment:	
5	Type	---
6	Trade name	A----
7	Serial number	---
8	to be installed on the following machines if indicated in their guidelines:	
9	Type	MERLO VARIABLE-REACH TRUCK MERLO ROUGH-TERRAIN VARIABLE-REACH TRUCK MERLO ROUGH-TERRAIN SLEWING VARIABLE-REACH TRUCK
10	Model interface	MERLO ZM--
11	complies with all the applicable provisions of Directive 2006/42/CE.	
12	This declaration of EC conformity concerns exclusively the machine placed on the market as new, except for the components and/or the operations carried out afterwards by the end user.	
13	Person authorised to draw up the technical dossier:	
14	MERLO PROJECT s.r.l. Via Nazionale, 9 - 12010 S. Defendente di Cervasca (CN) - IT	
15	San Defendente di Cervasca, --/--/----	
16	---	(Signature)
	Person authorised to draw up the declaration on behalf of the authorised representative	



The original EC declaration of conformity drafted in Italian is accompanied by a translation in the language of the country in which the machine is introduced on the market for the first time.

EC DECLARATION OF CONFORMITY OF THE CABLES

For attachments equipped with cables, a copy of the EC CERTIFICATE OF CONFORMITY is issued for the cable in question.



ATTACHMENT IDENTIFICATION

Modello - Model - Modèle - Modell - Modelo	
N° di fabbrica / Anno - Serial number / Year	
N° de serie / Année - Seriennummer / Baujahr	/
N° de serie / Año	
MERLO REF. No.	S.A.V.
Peso - Weight - Poids - Gewicht - Peso	kg ;lt
Volume - Volume - Volumen - Volumen	
Portata max (Kg) a (mm)	
Max payload (Kg) a (mm)	kg / mm
Charge max (Kg) a (mm)	
Max. Tragfähigkeit (kg) bei (mm)	
Capacidad max (Kg) a (mm)	
Pressione max - Max pressure - Presión maxi - Max Betriebsdruck - Presión max	bar
3M000185	
 TRE EMME Via Passatore, 2/a San Defendente di Cervasca 12010 (CN) ITALY	

PRELIMINARY CHECKS

Before every usage:

- ▶ Clean the attachment.
- ▶ Make sure that there are no **damaged or missing parts**. For attachments equipped with hook couplings, - especially check the functional status of the coupling and related locking device.
- ▶ Check the correct fastening **of the pins and relative retainers**.
- ▶ Install the attachment and, operating it with a movement with the engine at min rpm, make sure that there are no **oil leaks**.
- ▶ Make sure the **controls** function correctly.

If this is not the case, **DO NOT USE the attachment** and contact the Area Distributor or Dealer for technical assistance.

MAINTENANCE

EVERY 50 OPERATING HOURS

- ▶ Remove the attachment
- ▶ Switch off the **engine** of the machine.
- ▶ Grease the pins fitted with grease nipples.

ATTACHMENT LIFTING



WARNING!



RISK OF ACCIDENTS!

Before lifting an attachment, make sure that **the lifting attachments** used are in good working order and that their capacities are appropriate for the weight of the attachment indicated on the **ID PLATE**.

Only lift the attachment if unloaded.

To lift the attachment, use the **points indicated** with the following symbols:

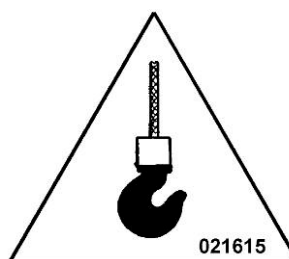

WARNING!



RISK OF ACCIDENTS!

DO NOT USE the attachment's lifting points to lift a load.



INSTALLATION



WARNING!



RISK OF ACCIDENTS!

During the installation of an attachment, make sure that there are **no people within the machine's radius of action**.

OPERATION OF THE QUICK-COUPLING CYLINDER (P)



WARNING!



RISK OF ACCIDENTS!

DO NOT USE the attachment if the machine's hydraulic pipeline (C) controlling the quick-coupling cylinder (P) has not been set in the rest position "D" to prevent accidental operation of the quick-coupling cylinder (P) itself and the risk of uncoupling the attachment.

Make sure that the machine's **hydraulic pipeline (C)** controlling the small cylinder (P) is connected to the **hydraulic connector [A]**.

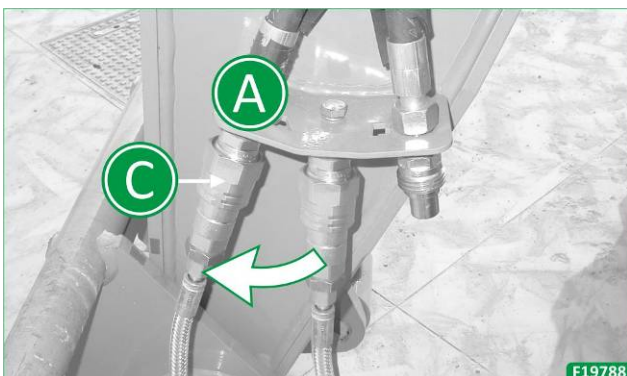

(If installed) Press and hold button (315) (refer to al **MODULE 1 → SECTION 3 → POSITION OF CAB COMMANDS → P1 AND P2 PANEL COMMANDS**).

Use the joystick command (1) to send the flow of oil to the hydraulic connector [A] (refer to **MODULE 1 → SECTION 3 → JOYSTICK**) to withdraw the **quick-coupling piston (P)**.

Release the control to make the quick-coupling piston (P) exit.

Once the attachment is installed:

- ▶ **Disconnect the hydraulic pipeline (C)** on the machine used to control the quick-coupling cylinder (P) from the hydraulic connector [A].
- ▶ **Connect the hydraulic pipeline (C)** of the machine used to control the quick-coupling cylinder (P) **to rest position "D"**.

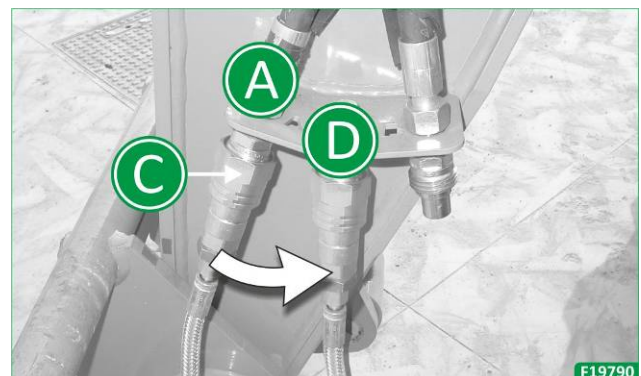

MECHANICAL COUPLING

**WARNING****GENERAL INFORMATION.**

The following images are given as an example in order to illustrate the installation operations for a generic TREEMME attachment with a quick-coupling device.

Position the machine close to the attachment with the boom completely withdrawn and lowered and the carriage in a vertical position.

Via the **joystick (1)** controls:

- ▶ Rotate the carriage downwards.
- ▶ Extend the boom almost as far as the attachment's couplings (A).



- ▶ Lift the boom until the carriage can be inserted in the **attachment's couplings**.



- ▶ Retract the **quick coupling piston (P)** as described in the previous paragraph.

- ▶ Turn the carriage upwards until **the attachment rests on the carriage**.



- ▶ Release the controls activated to make the **quick-coupling piston (P)** exit and complete the coupling of the attachment.
- ▶ Lift the boom and check FROM THE CAB the **correct insertion of the quick-coupling cylinder (P)** in the relative hole in the attachment.

**WARNING!****RISK OF ACCIDENTS!**

DO NOT TAKE UP A POSITION underneath the attachment in order to check the correct insertion of the quick-coupling cylinder (P) in the relative hole in the attachment.

DO NOT USE the attachment if the quick-coupling cylinder (P) is not correctly inserted in the hole in the attachment: In this case, lower the boom and repeat the installation procedure.



HYDRAULIC CONNECTION

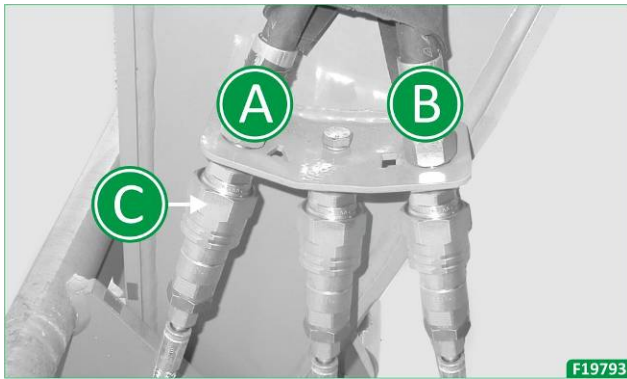

To allow **hydraulic movements of the attachment**:

- ▶ Connect the hydraulic pipeline (C) (indicated by the specific clamp) from the Attachments **to the hydraulic connector [A]**.
- ▶ Connect the second pipeline from the attachment **to the hydraulic connector [B]**.

ELECTRICAL CONNECTION

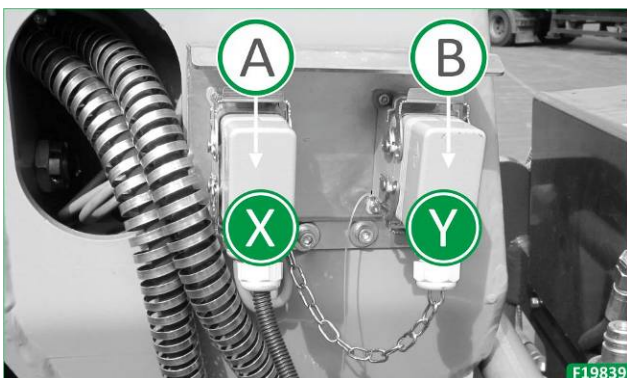

Remove the pin (B) from position (X) and **connect it to the support socket in position (Y)**.

Connect pin (A) from the attachment to the electrical socket in position (X).

ATTACHMENT CONTROL

See **MODULE 1 → SECTION 3 → JOYSTICK**.

Any other hydraulic movements will be described in the user instructions for the specific attachment.

DE-INSTALLATION

**WARNING!****RISK OF ACCIDENTS!**

During the de-installation of an attachment, make sure that there are **no people within the machine's radius of action**.

**WARNING!****RISK OF ACCIDENTS!**

NEVER ATTEMPT to remove an attachment by forcing it down to the ground.

**WARNING!****RISK OF ACCIDENTS!**

NEVER TAKE UP A POSITION underneath the attachment in order to check the position of the **quick-coupling cylinder (P)**.

To understand the position and operation of the commands described in this paragraph, refer to **MODULE 1 → SECTION 3 → JOYSTICK**.

- ▶ Before positioning the attachment, make sure that the ground is flat and suitable for supporting the weight indicated on the relative ID plate (refer to **MODULE 3 → SECTION 2 → ATTACHMENT IDENTIFICATION**).
- ▶ Press and hold down the **service brake (15)**.
- ▶ Place the gearbox selector switch (19) and the driving direction selector switch (20) in the neutral position "N".
- ▶ Engage the parking brake (37).
- ▶ Disengage the service brake (15).

**WARNING!****RISK OF ACCIDENTAL MOVEMENTS!**

Before releasing the **parking brake pedal (15)**, make sure that the parking brake (37) is engaged.

For electrically connected attachments:

- ▶ **Disconnect pin (A)** from the attachment from the electrical socket in position (X).
- ▶ **Remove the pin (B)** from position (Y) and **connect it** to the support socket in position (X).

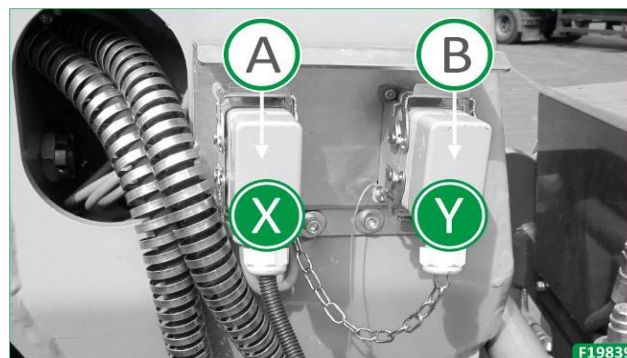

For hydraulically connected attachments:

- ▶ **Disconnect the hydraulic pipelines (E)** from the attachment from the hydraulic sockets [A] and [B] [figure 7] and then place them in the correct rest position on the attachment.

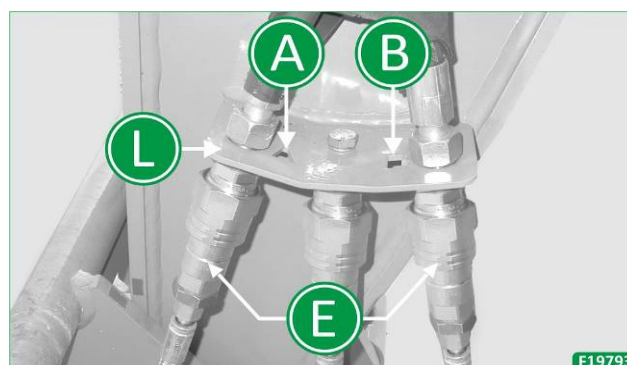

- ▶ **Disconnect the hydraulic pipeline (C)** of the machine used to control the quick-coupling cylinder (P) from the rest position "D" and **connect it to the hydraulic socket (A)** (figure 8).



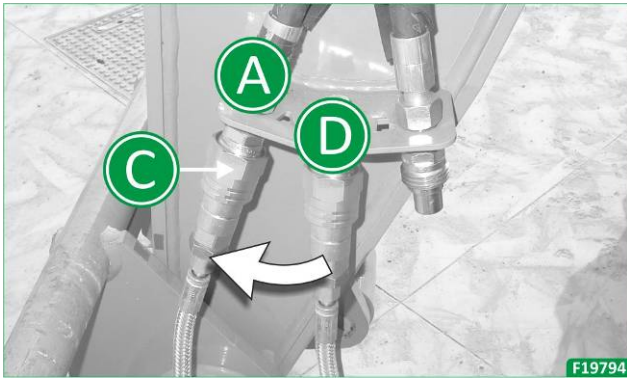

WARNING



RELEASING THE ATTACHMENT.

IT IS NOT POSSIBLE to **withdraw the quick-coupling cylinder (P)** if the hydraulic pipeline (C) on the machine is not connected to the hydraulic connector [A].

Using the commands on the **joystick (1)**:

- ▶ Retract the quick-coupling cylinder (P).
- ▶ Rotate the **carriage** downwards and then slide it out of the couplings (A) on the attachment.

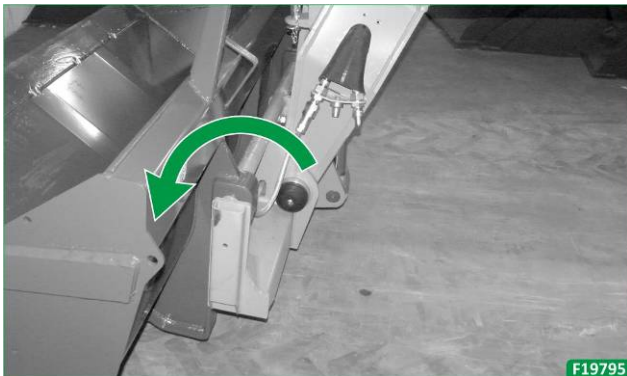

- ▶ If necessary **slightly lower the boom** further to free the attachment.

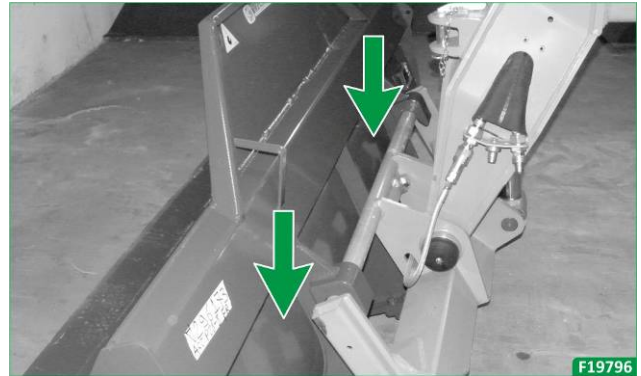

- ▶ Release the command of the **quick-coupling cylinder (P)** on the joystick (1).
- ▶ **Retract** the boom.



WARNING!



RISK OF ACCIDENTS!

If the machine has to be moved backwards, before doing so make sure that **there are no persons in the area of operations.**

ATTACHMENTS FOR FIXED LOADS



WARNING!



RISK OF ACCIDENTS!

DO NOT HANDLE suspended loads with attachments for fixed loads.



WARNING!



RISK OF ACCIDENTS!

Violent blows to the attachment can cause serious damage to the quick-coupling system and the **accidental release** of the attachment itself.



WARNING!



RISK OF ACCIDENTS!

DO NOT LIFT persons on-board the attachment.



WARNING



CIRCULATION ON PUBLIC ROADS.

In order to **drive on public roads** with the attachment installed, observe **the Highway Code of the country** where the machine is used and, wherever so envisaged, refer to the **type approval documents**.

ADDITIONAL CARRIAGES WITH FORKS

For instructions on installing the attachment, refer to **MODULE 3 → SECTION 2 → INSTALLING THE ATTACHMENT**.

For instructions on the use of the attachment refer to **MODULE 1 → SECTION 3 → JOYSTICK**.



WARNING!



RISK OF ACCIDENTS!

DO NOT INSTALL additional forks on the carriage or other attachments in place of the standard forks.



WARNING!



RISK OF ACCIDENTS!

DO NOT LIFT a load using the forks in a non-Symmetrical position in relation to the axis of the machine.



WARNING!



RISK OF ACCIDENTS!

DO NOT LIFT a load using only one fork.



EXTRA-WIDE FORK CARRIAGE WITH STANDARD FORKS [A0100]

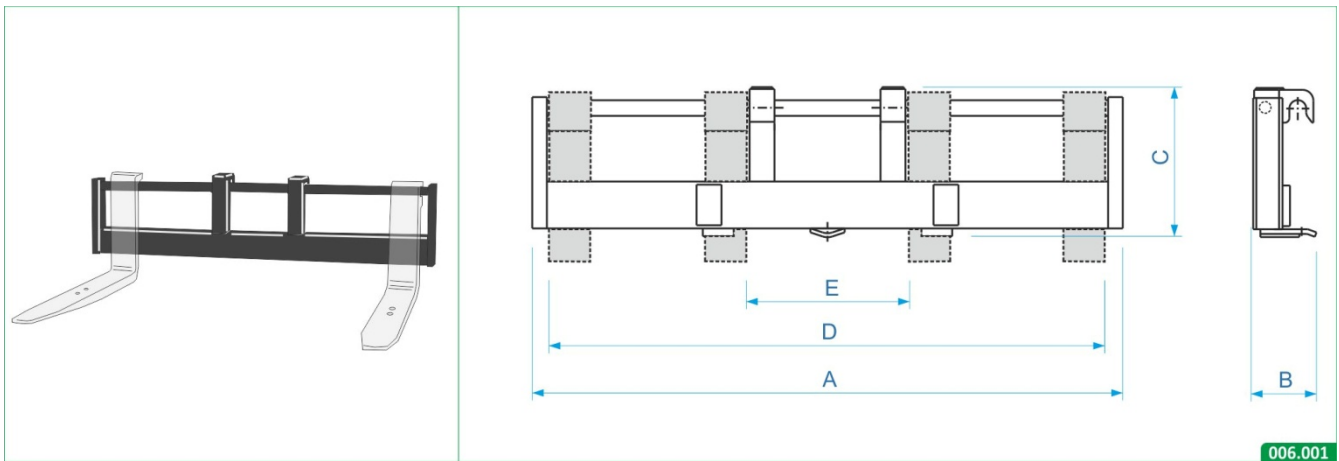

MERLO CODE	A0100	
	mm	in
A	1895	75
B	280	11
C	490	19
D	1790	70
E	510	20
	kg	lb
Weight	132	291

To install the standard forks refer to MODULE 3 → SECTION 1 → FORKS .

FEM ZM2 CARRIAGE WITH FEM III FORKS [A0200 | A0201 | A0210 | A0211]

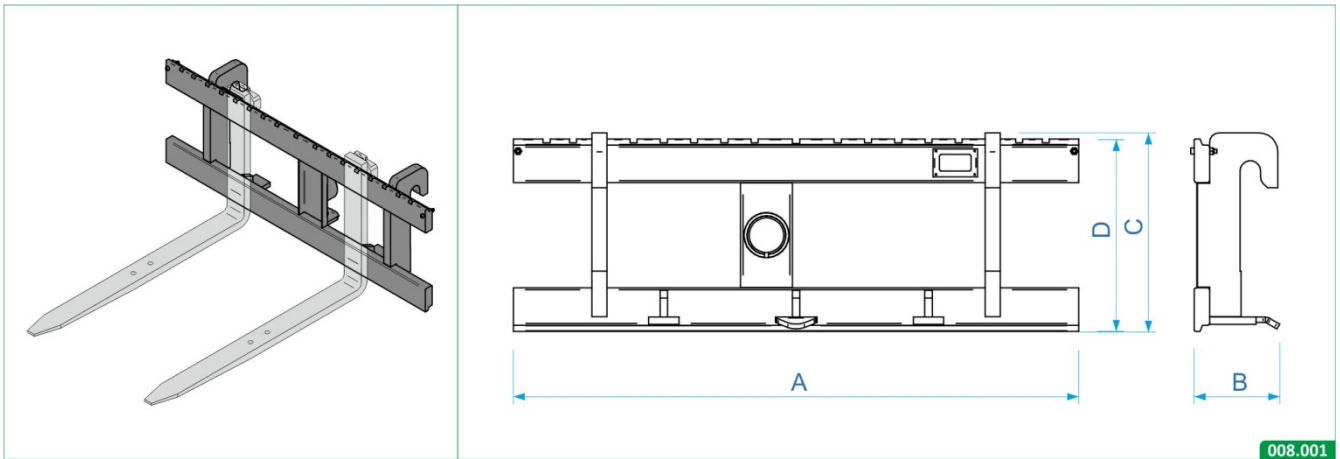

MERLO CODE	A0200		A0201		A0210		A0211	
	mm	in	mm	in	mm	in	mm	in
A	1500	59	1500	59	2000	79	2000	79
B	225	9	250	10	245	9.10	250	10
C	525	21	630	25	525	20	630	25
D	510	20	510	20	510	20	510	20
	kg	lb	Kg	lb	Kg	lb	kg	lb
Weight	145	320	156	344	185	408	190	419



To install the fem III forks:

- ▶ Lift the safety pin (A) of the forks.
- ▶ Manually insert the forks in the required position on the carriage.
- ▶ Insert the safety pin (A) in one of the grooves used to lock the fork's position.

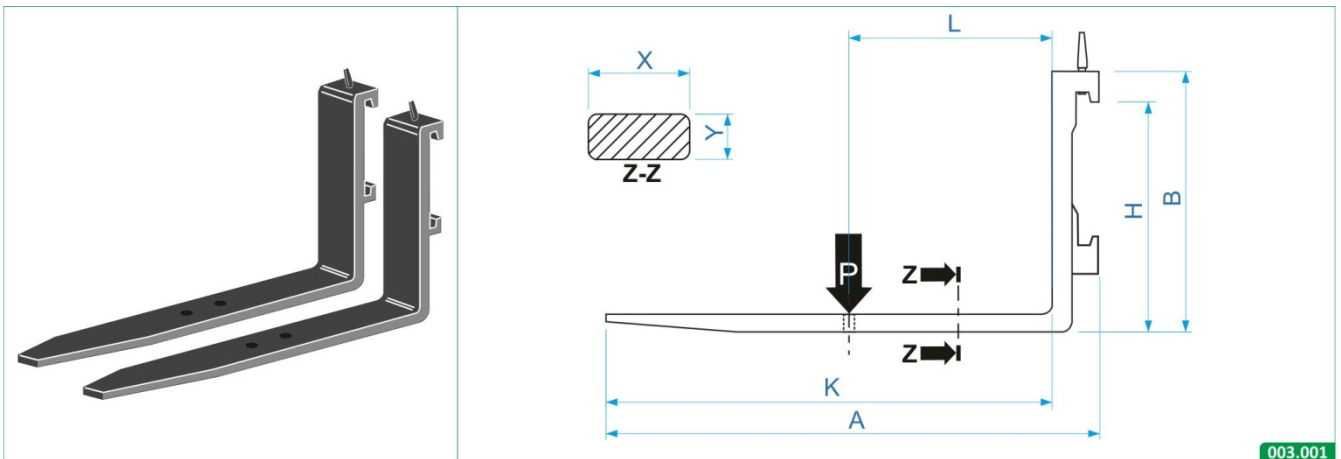
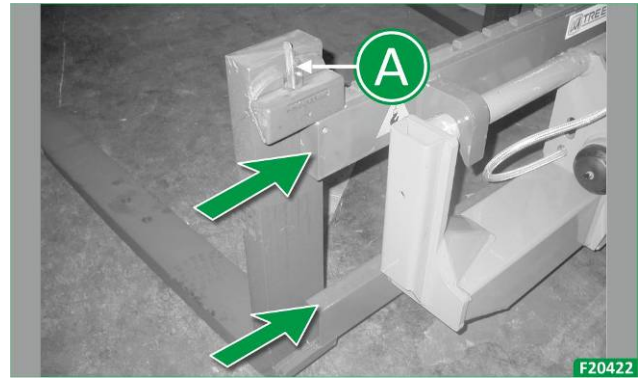

MERLO CODE	A0500	
	mm	in
K	1200	47
A	1290	50
B	655	26
X	125	5
Y	50	2
H	570	22
L	500	20
	kg	lb
Weight	83	183
Capacity	2150	4750

CARRIAGE WITH FLOATING STANDARD FORKS [A0291 | A0292]

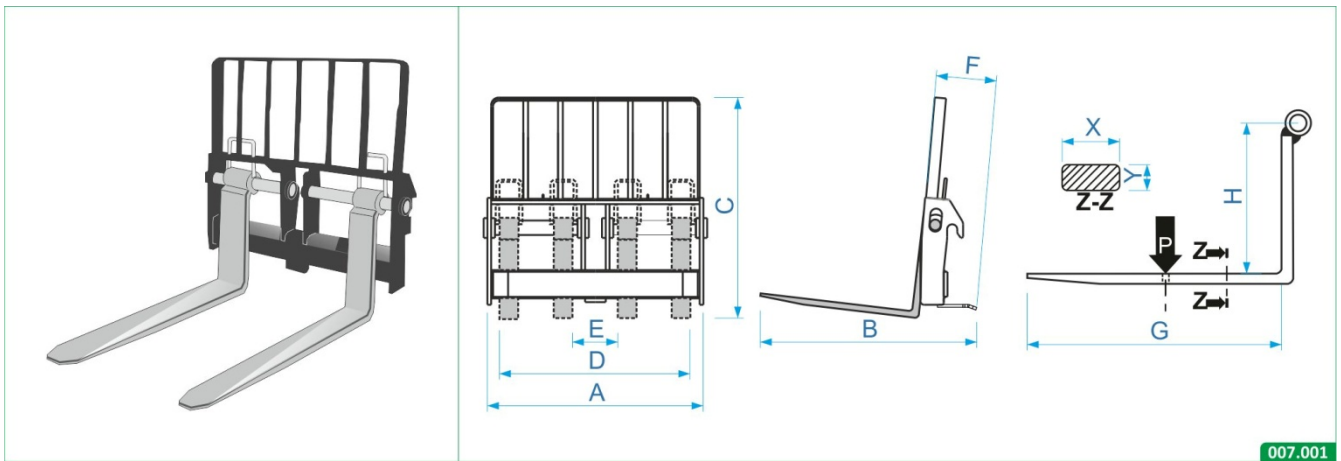

MERLO CODE	A0291		A0292	
	mm	in	mm	in
A	1200	47	1200	47
B	1560	61	1565	62
C	1200	47	1300	51
D	990	39	990	39
E	295	12	295	12
F	355	14	355	14
G	1200	47	1200	42
H	480	19	580	23
X	120	5	120	5
Y	50	2	50	2
	kg	lb	kg	lb
Weight	290	639	305	672
Capacity*	4000	8820	4000	8820

* of the attachment, not of the individual fork.



CARRIAGE WITH FLOATING FORKS FOR RUNNING ON ROAD [A0291A | A0292A]

The reference sales codes have a specific suffix (for example A, B, C, etc.) not shown in the chart.

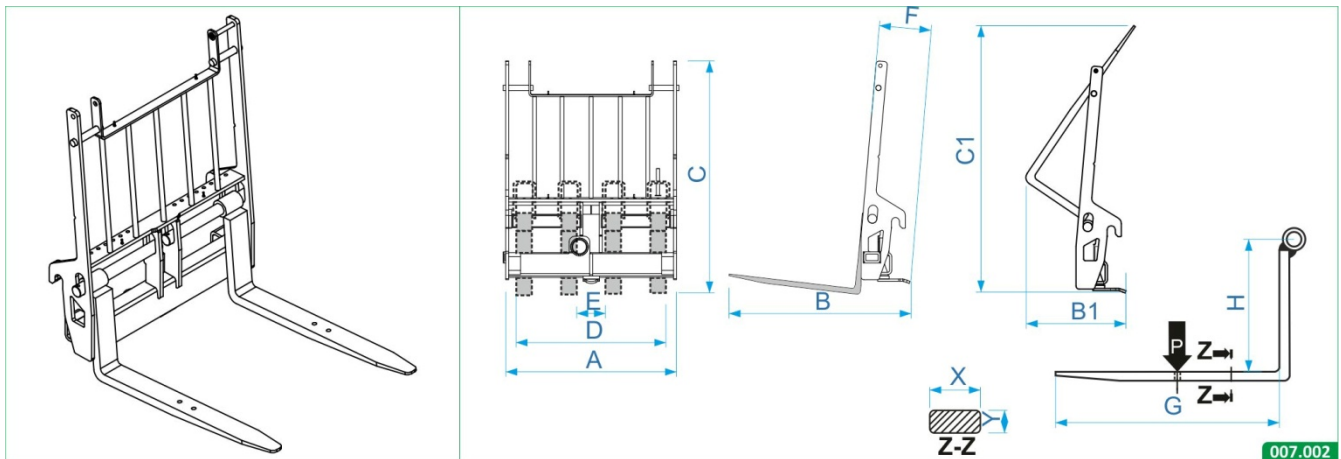

MERLO CODE	A0291A		A0292A	
	mm	in	mm	in
A	1200	47	1200	47
B	1560	61	1565	62
B1	660	26	697	28
C	1200	47	1300	51
C1	1747	69	1747	69
D	990	39	990	39
E	295	12	295	12
F	355	14	355	14
G	1200	47	1200	42
H	480	19	580	23
X	120	5	120	5
Y	50	2	50	2
	kg	lb	kg	lb
Weight	290	639	305	672
Capacity*	4000	8820	4000	8820

* of the attachment, not of the individual fork. *



WARNING!



For use on the road comply with all the regulations and provisions contained in the machine's Use and maintenance manual.

**WARNING****PRE-ARRANGEMENT FOR RUNNING ON THE ROAD.**

All operations described in the following paragraphs must be carried out by one operator!

- ▶ Move the fork against the outer part of the carriage.



- ▶ Remove the front protection for road circulation (5)

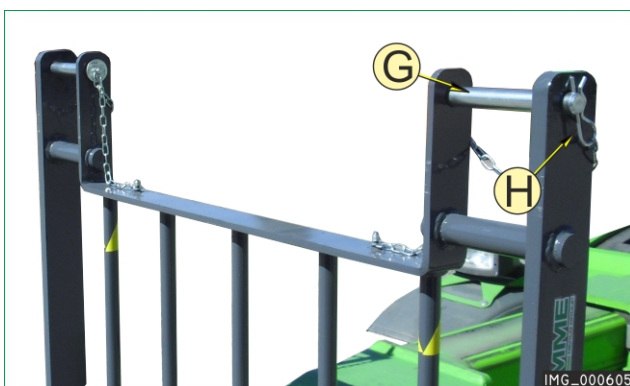

- ▶ Remove the locking pin (H) and the pin (3) from the rest position on the protective grid of the forks; perform the operation for both forks.

- ▶ Rotate the carriage forward until the protective grid is no longer resting on the forks.
- ▶ lower and extend the telescopic boom slightly so as to position the grid and the forks as illustrated.

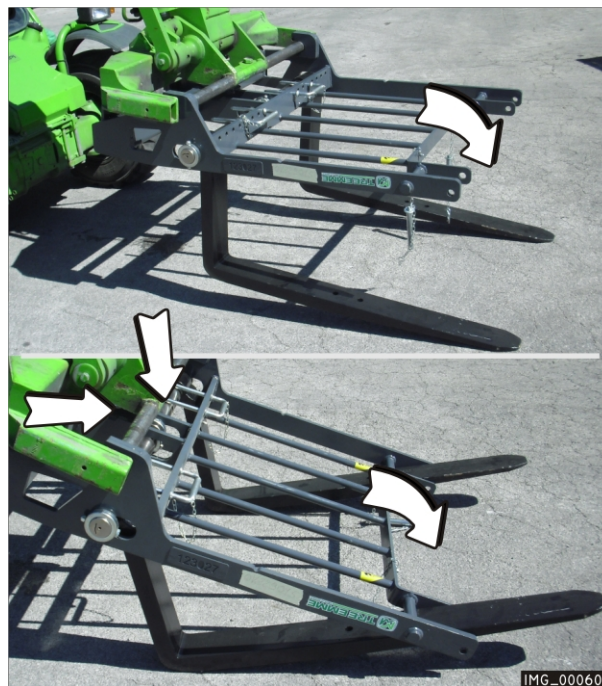

- ▶ Block both forks in this position with the pin (3) and the locking pin (H).

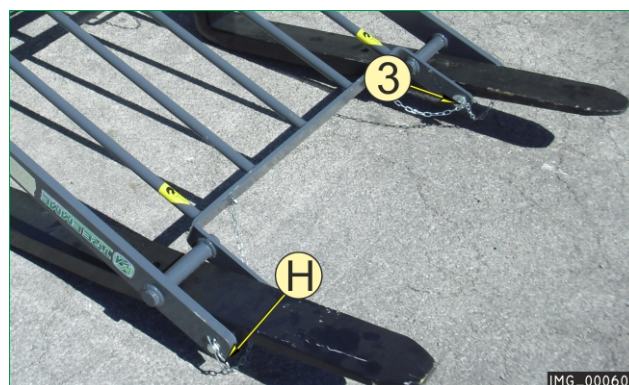

- ▶ Reposition the machine's carriage vertically.



- ▶ Raise the machine's telescopic boom slightly in order to aid the subsequent assembly operations



- ▶ Insert the front protection for circulation on the road (5) by hooking it to the protective grid of the forks by means of the appropriate lateral spring latches (6).



To position the forks in the working position, all previously described operations must be performed in reverse order.

CARRIAGE WITH SLIM FLOATING FORKS [A0293 | A0294]

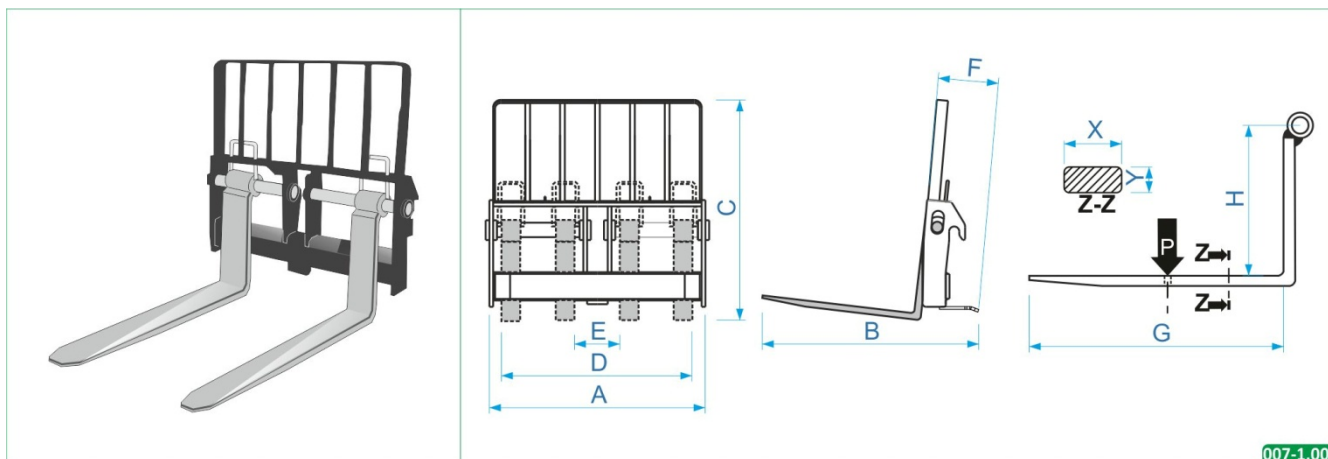

MERLO CODE	A0293		A0294	
	mm	in	mm	in
A	1200	47	1200	47
B	1545	61	1550	61
C	1180	46	1280	50
D	990	39	990	39
E	295	12	295	12
F	355	14	355	14
G	1200	47	1200	47
H	480	19	580	23
X	100	4	100	4
Y	35	1	35	1
	kg	lb	Kg	lb
Weight	220	485	230	507
Capacity*	1500	3310	1500	3310

* of the attachment, not of the individual fork.



WARNING!



RISK OF ACCIDENTS!

The capacity of the attachment is less than the **rated capacity** of the machine: before using the attachment, check the **capacity (kg)** and **load distance (mm)** values shown on the ID plate.



TRAVELLING LIFT ON STANDARD CARRIAGE [A0281 | A0282]

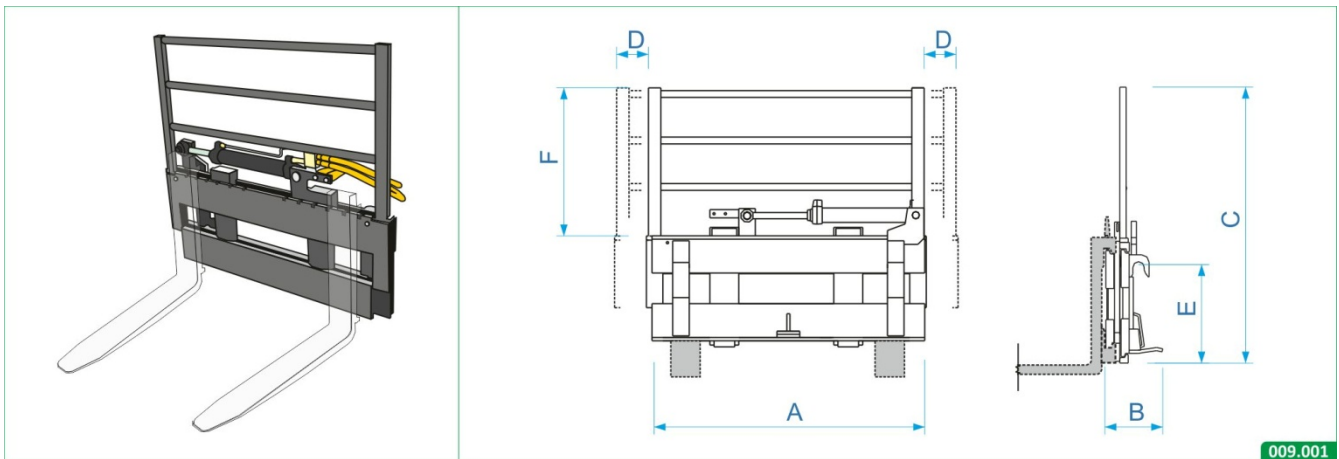

MERLO CODE	A0281		A0282	
	mm	in	mm	in
A	1355	53	1355	53
B	300	12	300	12
C	1250	49	1250	49
D	154	6	154	6
E	525	21	425	17
F	717	28	717	28
	kg	lb	Kg	lb
Weight	410	904	380	838
Capacity*	4000	8820	4000	8820

* of the attachment, not of the individual fork

LOADERS

For instructions on installing the attachment, refer to MODULE 3 → SECTION 2 → INSTALLING THE ATTACHMENT.

For instructions on the use of the attachment refer to MODULE 1 → SECTION 3 → JOYSTICK.

**WARNING!****RISK OF ACCIDENTS!**

DO NOT CAUSE violent blows to the bucket loader since they can cause serious damage to the quick-coupling system and the **accidental release** of the attachment itself.

**WARNING!****RISK OF TIPPING OVER!**

Arrange the load **uniformly** inside the attachment.

**WARNING!****RISK OF PUNCTURES!**

DO NOT hit the tyre with the loader, to avoid possible punctures or damage.

**WARNING****LOADER WITH GRAB.**

Pay close attention when **closing the grab** to prevent the material loaded damaging the tips.

**WARNING****LOAD CHARTS.**

A specific machine's load chart indicates the machine's **maximum work area** with reference to the specific weight of the material loaded.

**WARNING****DAMAGE TO BOOM STRUCTURE.**

Do not use the attachment to compact material.

Do not perform digging or loading operations with the telescopic boom extended or using extension movements.

When driving the machine **on public roads** with the loader installed, refer to the type-approval documents and install the appropriate front guard.

For ROTO MODELS:

**WARNING****POSITIONING THE LOADER.**

The assistance of an additional operator on the ground (OPERATOR 2) and the use of a **lifting accessory** are required.





WARNING!



RISK OF ACCIDENTS!

DO NOT USE the anchor point on the second extension of the machine's boom to **lift a load**.

- ▶ **Remove** the loader and place it on the ground.
- ▶ (OPERATOR 2) Pull the two **handles (M)** on the support outwards and turn them downwards.



- ▶ (OPERATOR 2) Connect the lifting accessory to the **anchor point** on the second extension of the machine's boom.
- ▶ Handle the machine's boom in order to suspend the **lifting accessory** with the free end at the specific lifting point of the attachment (refer to **MODULE 3 → SECTION 2 → LIFTING**).
- ▶ (OPERATOR 2) **Couple** the free end of the lifting accessory to the attachment's lifting point [figure 2].
- ▶ Use the boom's movements to **lift and handle the attachment** until it is coupled with the support [figures 3 and 4]. (OPERATOR 2) From the ground, manually guide the positioning of the attachment until it is coupled on the **support**.

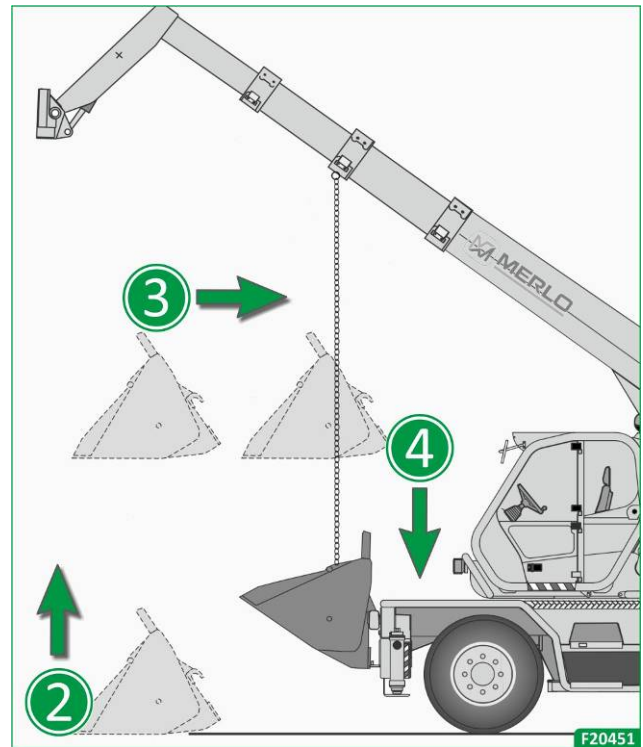

- ▶ Retract and lower the **boom**.
- ▶ (OPERATOR 2) Remove the lifting accessory.

Perform the operations indicated in reverse order to remove the loader from the support.

BUCKET LOAD CHARTS

The following information is provided in addition to the information in **MODULE 2**.

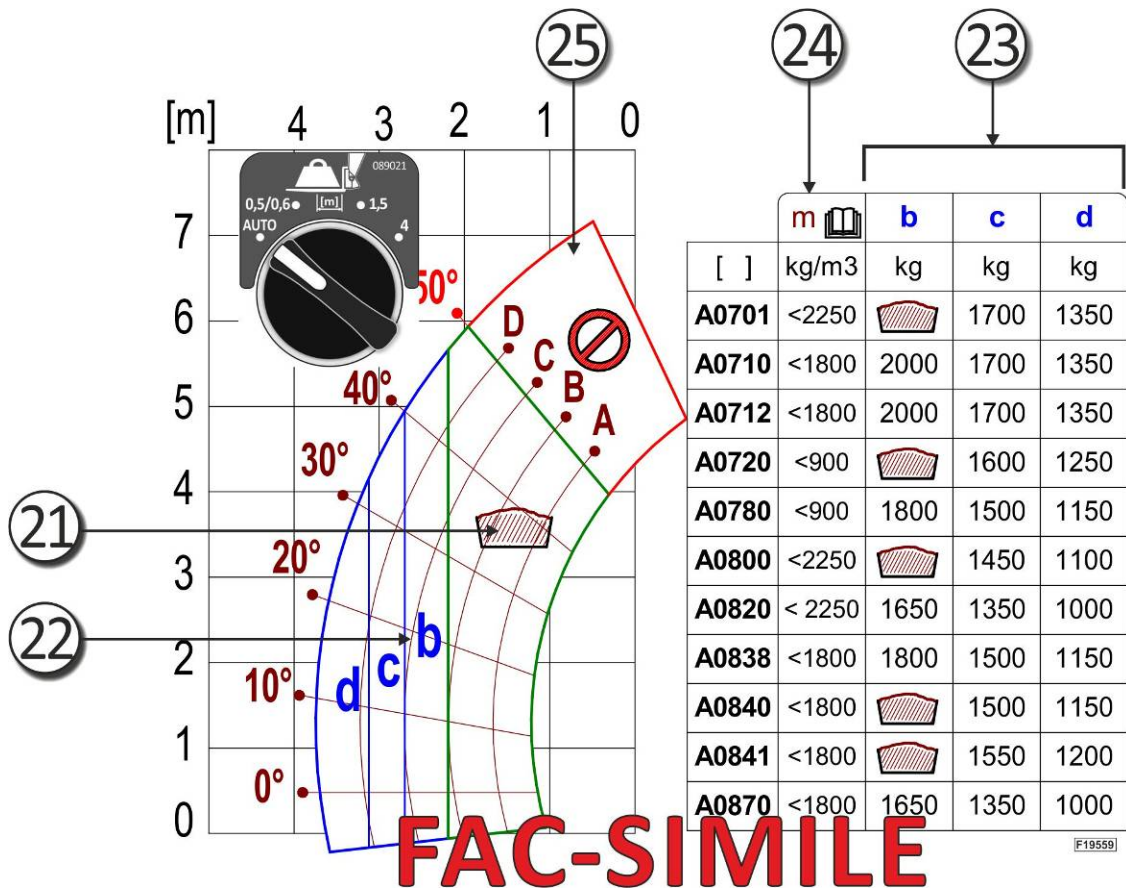

FAC-SIMILE

- 21) Bucket loader work area filled to max available capacity with material having the specific weight indicated in column (24).
- 22) Bucket loader work area with load indicated in the corresponding column (23).
- 23) Load Table.
- 24) Maximum specific weight of the material contained in the loader (refer to the TABLE OF MATERIAL DENSITIES FOR USING BUCKET LOADERS).
- 25) Work area not allowed.



TABLE OF MATERIAL DENSITIES FOR USING BUCKET LOADERS

MATERIALS WITH DENSITY 0 - 900 (kg/m³)

CORK	LIGNITE	SAWDUST	POWDERED MILK
SNOW	SOAP	TOBACCO	BENTONITE
VEGETAL CARBON	SUGAR	OATS	GLUE
DRY PEAT	BUTTER	ZINC OXIDE	COTTON
BRAN	PELLETS CHIPS	SOLID URBAN WASTE	COTTON SEEDS
COFFEE	CHOCOLATE POWDER	WALNUTS	PUMICE STONE
FISH	WHEAT	CRUSHED ICE	RICE
GRAPHITE POWDER	APPLES	PEANUTS	MAIZE
TIMBER	SHELLS	POTATOES	BEANS

MATERIALS WITH DENSITY 900 - 1,800 (kg/m³)

ICE	MAGNESIUM SULPHATE	POTASSIUM CHLORIDE	ALUMINIUM OXIDE
OIL	WET PEAT	IRON SULPHATE	LIME
LEATHER	TAR	WOOL	LIMESTONE
RUBBER	LOOSE STONES	BAKELITE	QUARTZ
BEESWAX	CALCIUM CARBIDE	SLATE POWDER	CRUSHED MARBLE
SODIUM	PAPER	FLINTSTONE	DRY GRAVEL
LOOSE EARTH	SALT	CEMENT POWDER	NICKEL ORE
DRY SAND	BAUXITE	COAL	LOOSE CLAY
LOOSE MUD	MAGNESIUM SULPHATE	POTASSIUM CHLORIDE	ALUMINIUM OXIDE
BROKEN GLASS	POWDERED MICA	CRUSHED STONE	

MATERIALS WITH DENSITY 1,800 - 2,200 (kg/m³)

COMPACT CLAY	WET SAND	COMPACT EARTH	CEMENT
COMPACT MUD	MAGNESIUM OXIDE	WET GRAVEL	ASPHALT
MANGANESE OXIDE	BASALT	BRICKS	TALC POWDER

DIGGING BUCKET [A0699 | A0700 | A0701 | A0706]

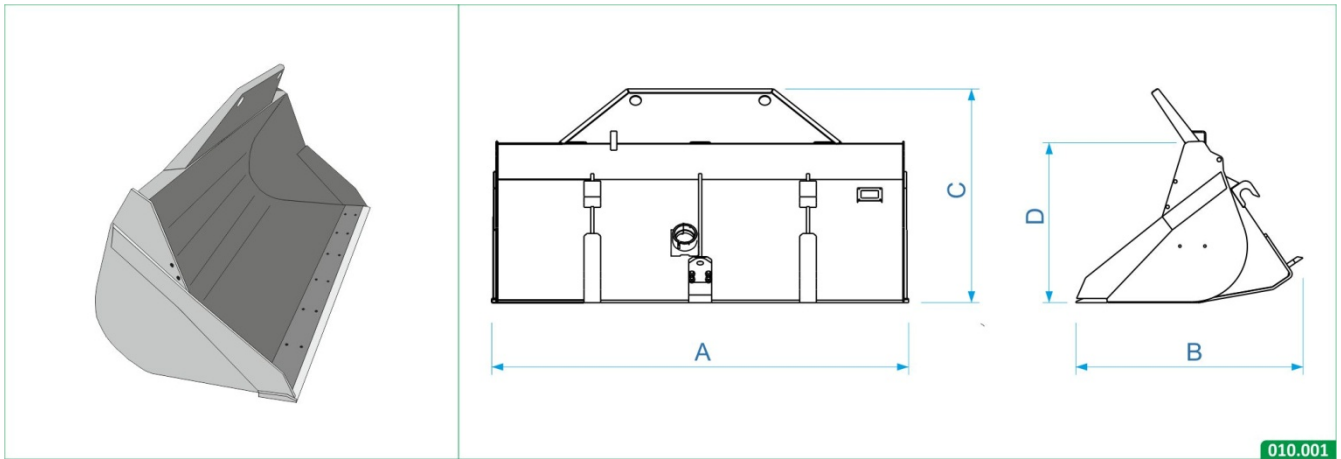

MERLO CODE	A0699		A0700		A0701		A0706	
	mm	in	mm	in	mm	in	mm	in
A	1840	72	2000	79	2240	88	2440	96
B	950	37	1100	43	1100	43	1100	43
C	940	37	1020	40	1020	40	1020	40
D	675	27	760	30	760	30	760	30
	kg	lb	kg	lb	kg	lb	kg	lb
Weight	300	661	360	794	400	882	430	948
	l	gal	l	gal	l	gal	l	gal
Load capacity	550	144	800	210	900	236	1000	262



REHANDLING BUCKET [A0710 | A0712 | A0715]

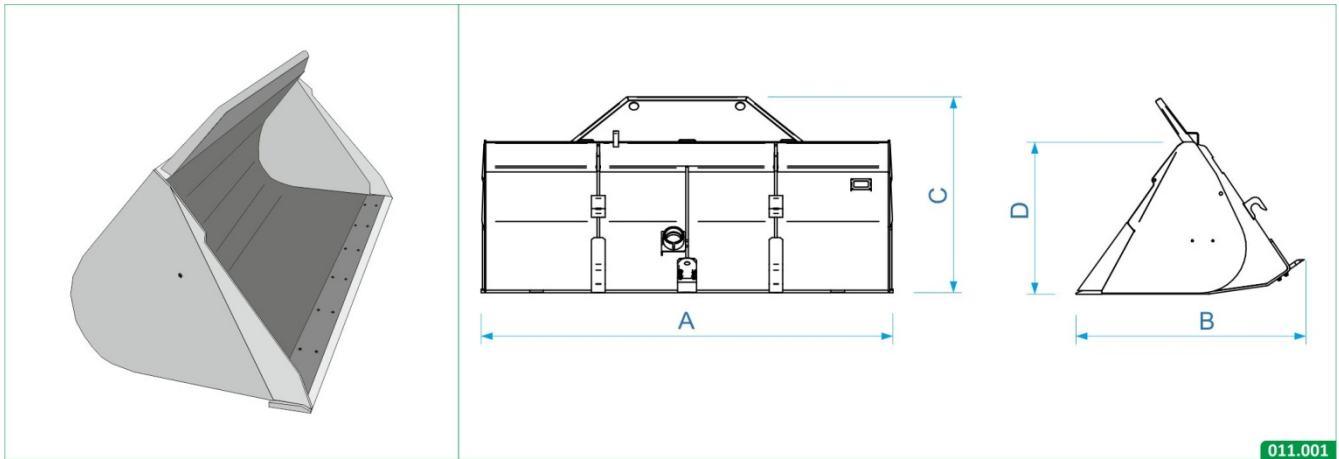

MERLO CODE	A0710		A0715		A0712	
	mm	in	mm	in	mm	in
A	2240	88	2240	88	2400	94
B	1330	52	1245	49	1330	52
C	1140	45	1060	42	1140	45
D	880	35	835	33	880	35
	kg	lb	kg	lb	kg	lb
Weight	390	860	380	838	410	904
	l	gal	l	gal	l	gal
Load capacity	1250	327	1250	327	1350	353

BULK MATERIAL BUCKET [A0713 | A0714 | A0716 | A0720 | A0780 | A0782]

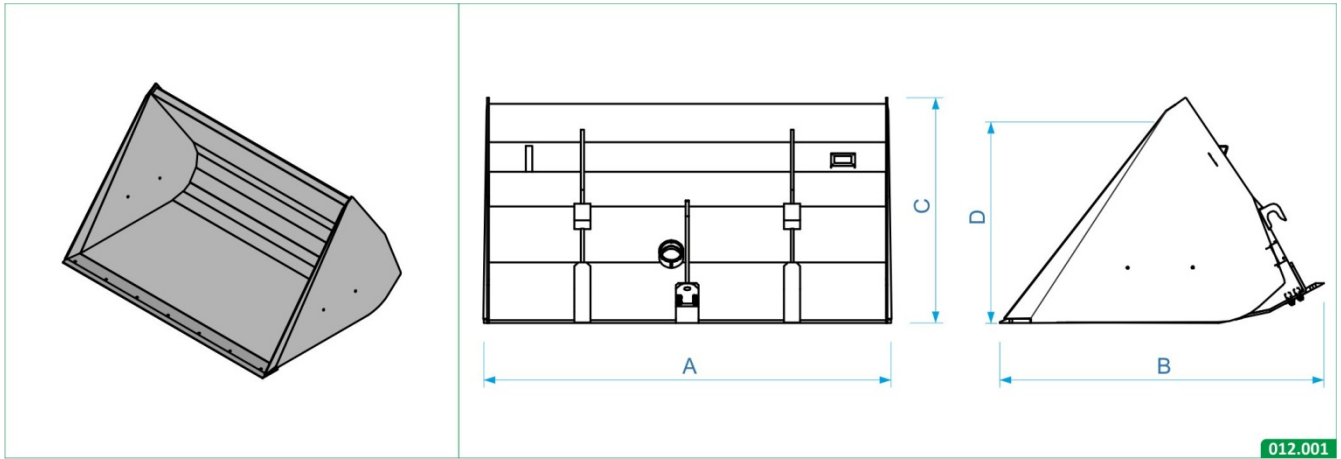

MERLO CODE	A0716		A0713		A0714		A0720		A0780		A0782	
	mm	in	mm	in	mm	in	mm	in	mm	in	mm	in
A	1840	72	2000	79	2240	88	2400	95	2400	95	2500	98
B	1600	63	1590	63	1600	63	1600	63	1760	69	1935	76
C	1085	43	1100	43	1085	43	1085	43	1190	47	1375	54
D	1035	41	1050	41	1035	41	1035	41	1130	44	1305	51
	kg	lb	kg	lb	kg	lb	kg	lb	kg	lb	kg	lb
Weight	435	959	435	959	485	1069	490	1080	605	1334	695	1532
	l	gal		gal	l	gal	l	gal	l	gal	l	gal
Load capacity	1500	396	1700	449	1800	475	2000	528	2500	660	3000	792



4x1 MULTI-FUNCTION LOADER [A0800 | A0810 | A0820 | A0860 | A0870]

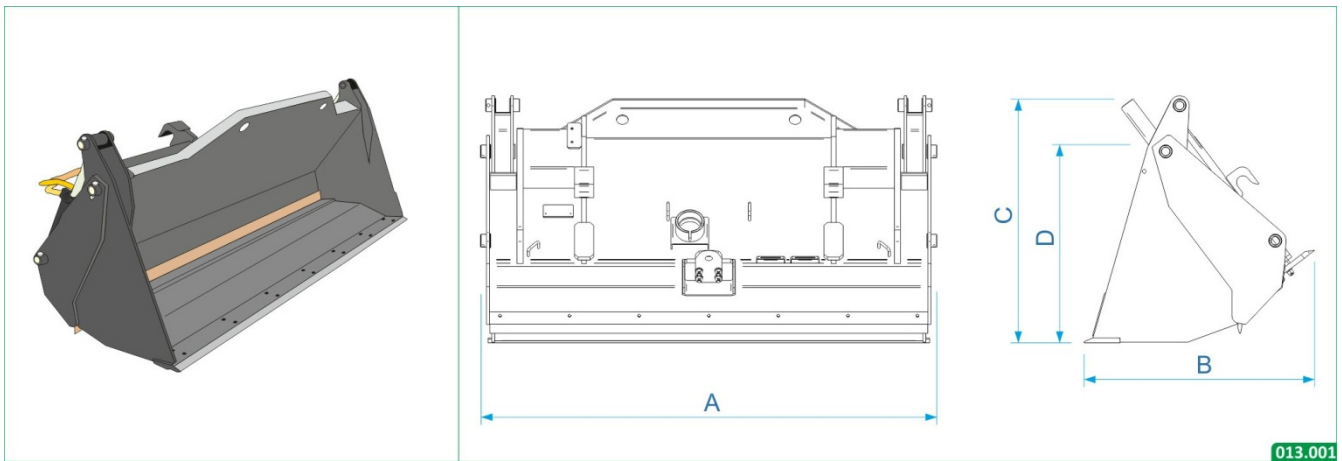

MERLO CODE	A0800		A0810		A0820		A0860		A0870	
	mm	in	mm	in	mm	in	mm	in	mm	in
A	2305	91	1905	75	2305	91	2585	102	2305	91
B	870	34	870	34	975	38	1595	63	1020	40
C	1030	41	1030	41	1110	44	1675	66	1245	49
D	765	30	765	30	845	33	1195	47	970	38
	kg	lb	kg	lb	kg	lb	kg	lb	kg	lb
Weight	720	1587	630	1389	780	1720	1220	2690	840	1582
	l	gal	l	gal	l	gal	l	gal	l	gal
Load capacity	800	211	600	159	1000	264	3000	792	1250	330

To **unload material**, slant the loader downwards or slant upwards and slowly open it.

To use the attachment as **pushing blade** :

- ▶ fully retract the telescopic boom
- ▶ completely open the loader;
- ▶ Place the pushing blade on the ground;
- ▶ Push the material by moving slowly and uniformly forwards with the machine.

MULTIPURPOSE BUCKET WITH GRAB [A0836* | A0838* | A0840* | A0841* | A0843*]

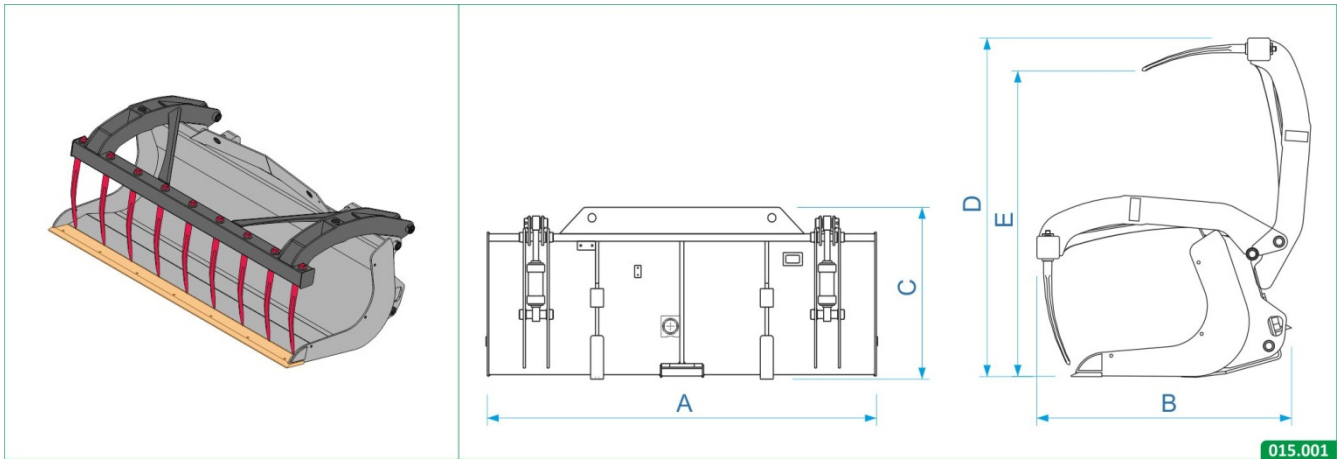

MERLO CODE	A0836		A0838		A0840		A0841		A0843	
	mm	in	mm	in	mm	in	mm	in	mm	in
A	1840	72	2400	94	2240	88	2000	79	2400	95
B	1165	46	1255	49	1260	50	1260	50	1440	57
C	840	33	975	38	840	33	835	33	995	39
D	1550	61	1725	68	1635	64	1635	65	1910	75
E	1255	49	1380	54	1330	52	1330	53	1650	65
	kg	lb	kg	lb	kg	lb	kg	lb	kg	lb
Weight	497	1096	660	1455	605	1334	570	1257	700	1543
	l	gal	l	gal	l	gal	l	gal	l	gal
Load capacity	700	185	1200	317	1000	264	900	237	1500	396

* These **MULTIPURPOSE BUCKET WITH GRAB** are available in several versions depending on the **type of grab**. The reference sales codes have a specific suffix (for example B, C, etc.) not shown in the chart.



FORKS WITH TINES

For instructions on installing the attachment, refer to MODULE 3 → SECTION 2 → INSTALLING THE ATTACHMENT.

For instructions on the use of the attachment refer to MODULE 1 → SECTION 3 → JOYSTICK.

**WARNING!****RISK OF PUNCTURES!**

With the boom retracted **DO NOT SLANT** the carriage excessively downwards: the tips may interfere with the tyres.

**WARNING!****RISK OF TIPPING OVER!**

Arrange the load **uniformly** inside the attachment.

**WARNING!****RISK OF ACCIDENTS!**

DO NOT LIFT a load using only one tip.

**WARNING****DAMAGE TO THE ATTACHMENT.**

Pay close attention when **closing the grab** (for attachments with grab) to prevent the material loaded damaging the tines.

**WARNING****ROAD CIRCULATION.**

Lift the **foldable tines** completely before travelling on public roads (for equipped models).



MANURE FORK WITH GRAPPLE [A2300 | A2301]

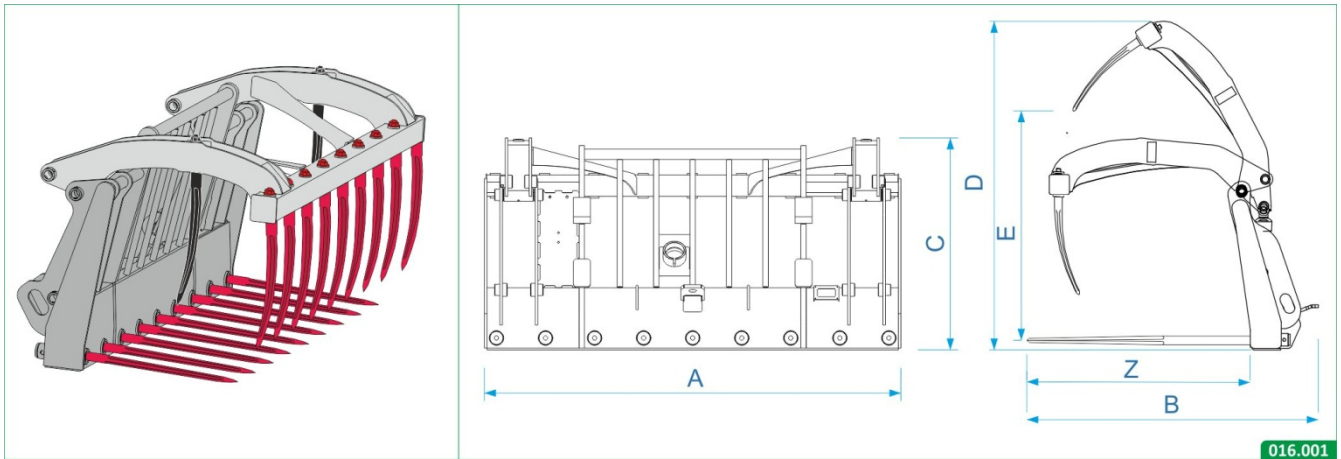

MERLO CODE	A2300		A2301	
	mm	in	mm	in
A	2280	90	1945	77
B	1285	51	1275	50
C	955	38	955	38
D	1755	69	1755	69
E	1380	54	1380	54
Z	795	31	795	31
	kg	lb	kg	lb
Weight	580	1280	518	1142
Capacity*	1200	2645	1000	2205

* of the attachment, not of the individual tip.



BALE FORK WITH 2/3 FOLDABLE TINES WITH SLIDING GUARD
 [A2231 | A2232 | A2233 | A2234]

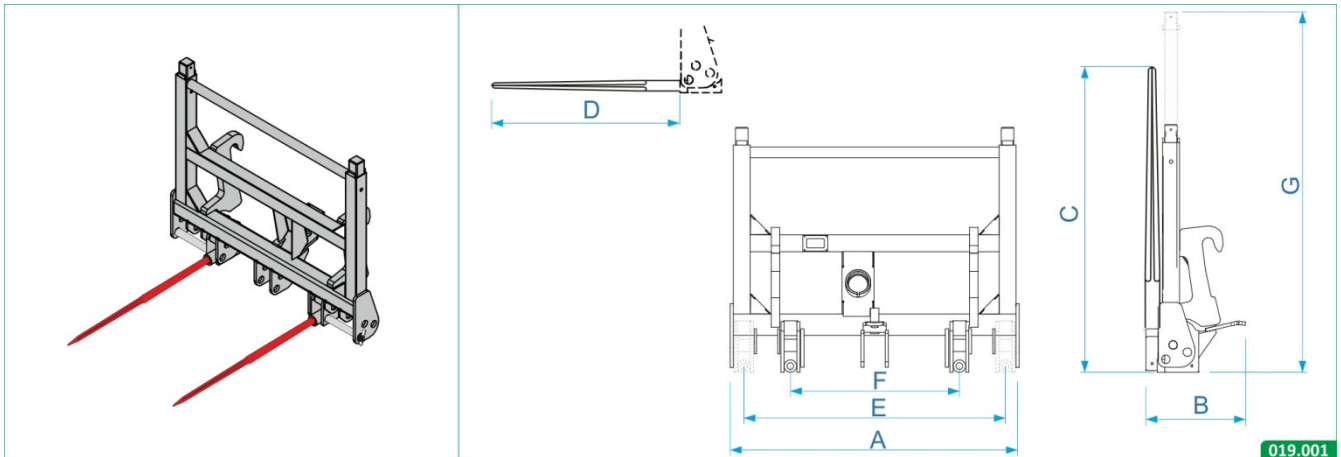

MERLO CODE	A2331 A2332 A2333 A2334	
	mm	in
A	1390	55
B	470	19
C	1035 1235 1415 1415	41 49 56 56
D	840 1040 1200 1200	33 41 47 47
E	800	31
F	1240	49
G	1630	64
	kg	lb
Weight	220 230 240 220	485 507 529 485
Capacity*	1500 1500 1500 1000	3310 3310 3310 2205

* of the attachment, not of the individual tip.

2/3 FOLDABLE TINES BALE FORK WITH HYDRAULIC SLIDING PROTECTION [A2340]

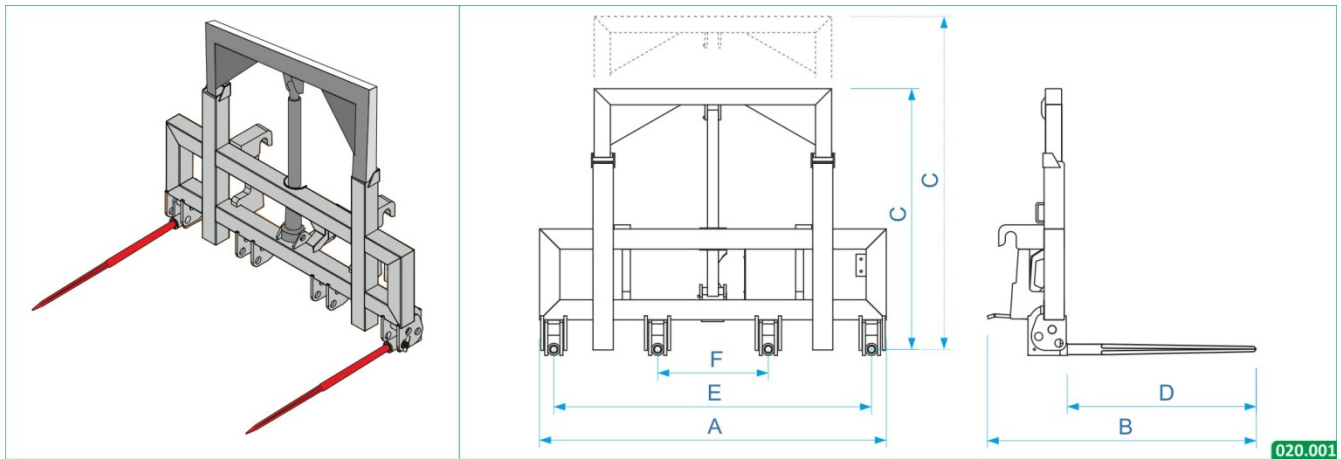

MERLO CODE	A2340	
	mm	in
A	1720	68
B	450	18
C	1320 ÷ 1900	52 ÷ 75
D	1040	41
E	1570	62
F	550	22
G	1190	47
	kg	lb
Weight	320	705
Capacity*	1500	3310

* of the attachment, not of the individual tip.

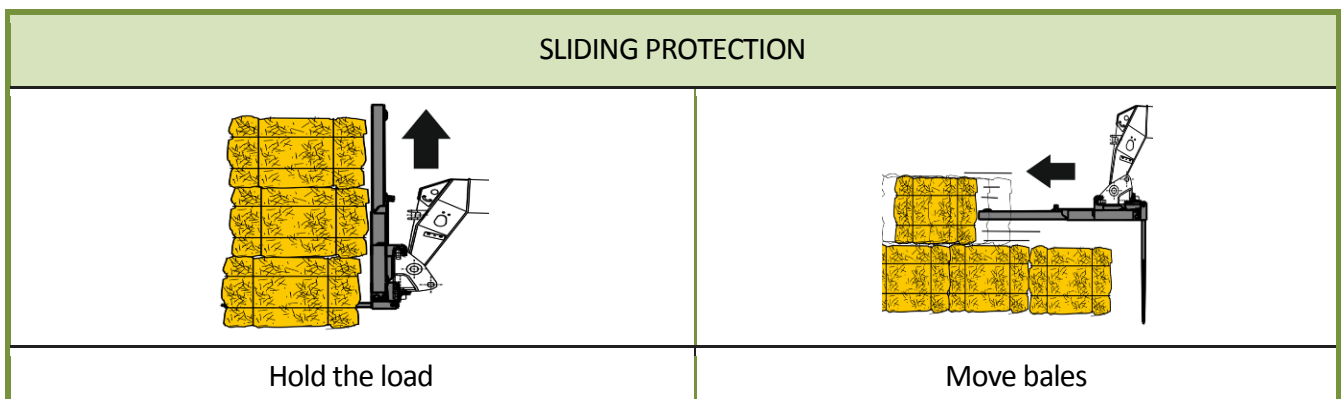

3 FOLDABLE TINES BALE FORK WITH GRAB (02320)

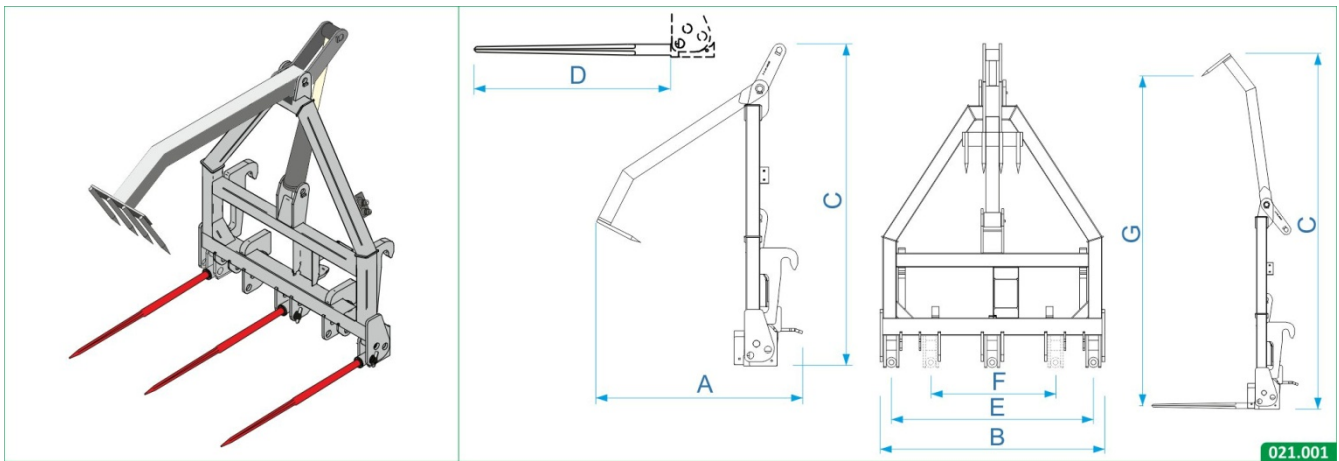

MERLO CODE	A2320	
	mm	in
A	1195	47
B	840	33
C	1865 ÷ 2790	73 ÷ 110
D	1040	41
E	1170	46
F	730	29
G	2575	101
	Kg	lb
Weight	240	530
Capacity*	1500	3310

* of the attachment, not of the individual tip.

After **loading the material**, lower the grab to lock on the attachment.

GRIPPERS

For instructions on installing the attachment, refer to MODULE 3 → SECTION 2 → INSTALLING THE ATTACHMENT.

For instructions on the use of the attachment refer to MODULE 1 → SECTION 3 → JOYSTICK.

If the machine is equipped with 2 hydraulic functions, refer to MODULE 1 → SECTION 5 → PRE-ARRANGEMENT FOR COMMAND WITH 2 HYDRAULIC FUNCTIONS.

**WARNING!****RISK OF ACCIDENTS!**

Before using the attachment, refer the **load chart** to identify the maximum capacity of the attachment in combination with the machine since:

- ▶ the **combination capacity** may be lower than the machine's maximum capacity, or
- ▶ the **rated capacity of the attachment** may be lower than the machine's maximum capacity.

**WARNING!****RISK OF TIPPING OVER!**

Arrange the load on the attachment in a **central position** in relation to the axis of the machine.

**WARNING!****RISK OF ACCIDENTS!**

DO NOT use the attachment to drag the load.

**WARNING!****RISK OF ACCIDENTS!**

DO NOT HANDLE a load having a diameter larger than the max. diameter ($\emptyset D$) indicated in the **TECHNICAL INFORMATION** for the attachment.

**WARNING!****RISK OF PUNCTURES!**

With the boom retracted **DO NOT SLANT** the carriage excessively downwards: the tips may interfere with the tyres.

**WARNING!****RISK OF ACCIDENTS!**

Respect the load diameter values..

**WARNING!****RISK OF ACCIDENTS!**

When using the trunk gripper, pay attention to the risk of the **material being handled falling**.



DOUBLE LOG GRIPPER [A2200]

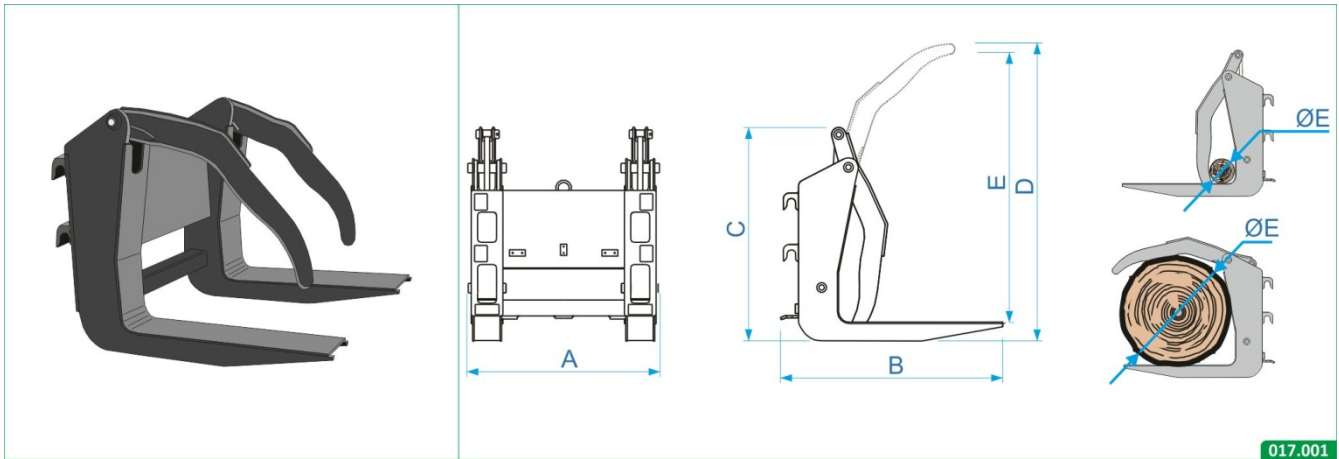

MERLO CODE	A2220	
	mm	in
A	1215	48
B	1420	56
C	1345	53
D	1890	74
E	1710	67
ØE	150 ÷ 1000	6 ÷ 39
	Kg	lb
Weight	590	1300
Capacity*	7000	15440

BALE GRIPPER [A2400 | A2401 | A2402 | A2403 | A2405 | A2406 | A2407 | A2408 | A2409 | A2411 | A2412 | A2413]

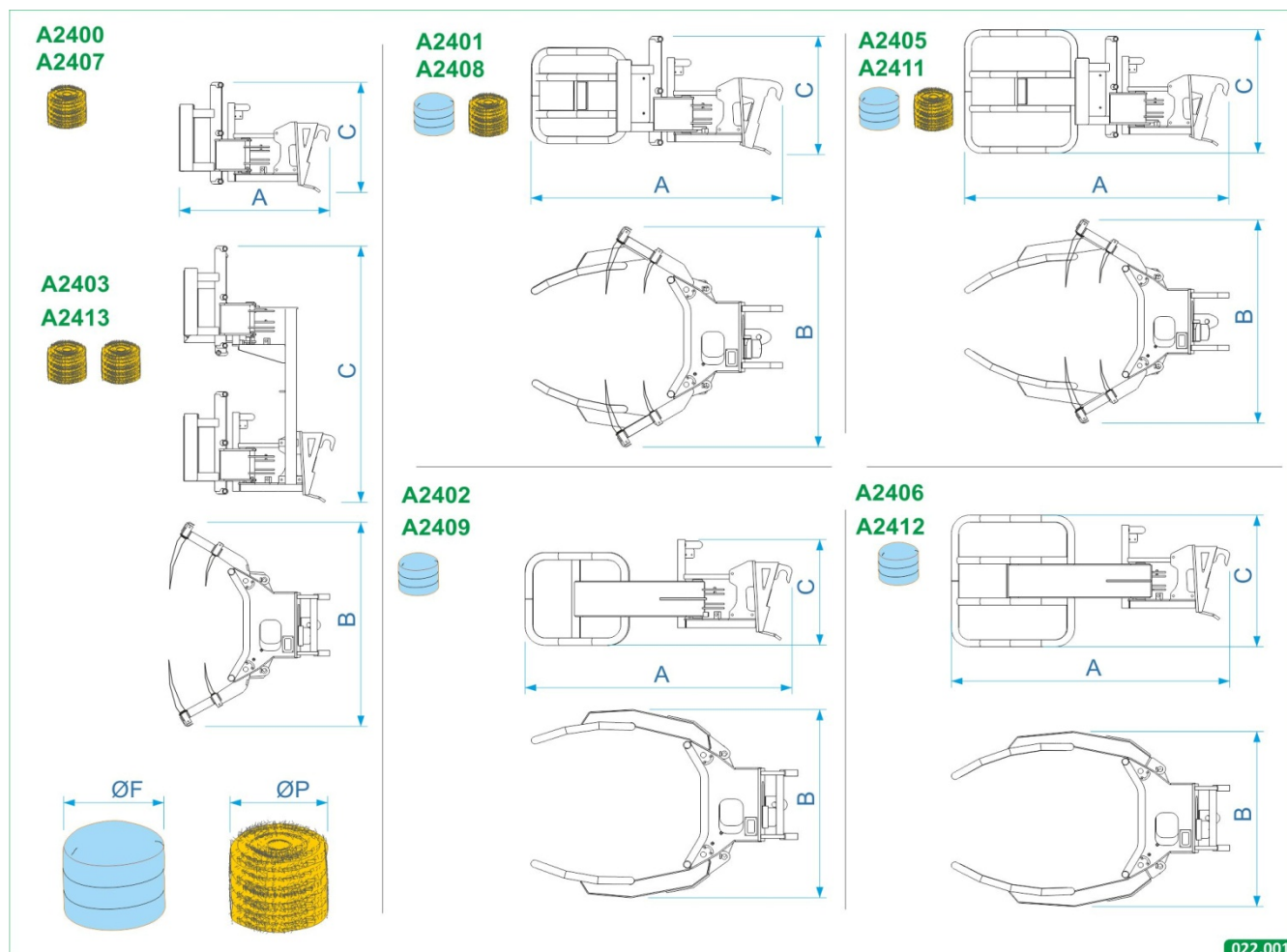

022.001

MERLO CODE	A2400		A2403		A2401		A2411		A2409		A2412	
	A2407		A2413		A2408		A2405		A2402		A2406	
	mm	in	mm	in	mm	in	mm	in	mm	in	mm	in
A	1055	42	1055	41	1655	65	1835	72	1690	67	1835	72
B	1485	58	1485	58	1495	59	1495	59	1215	48	1200	47
C	800	31	1850	73	905	36	725	29	680	27	905	36
ØF	1200	47	1200	47	1200	47	1200	47	---	---	---	---
	2000	79	2000	79	2000	79	2000	79	---	---	---	---
ØP	---	---	---	---	1400	55	1400	55	1400	55	1400	55
	---	---	---	---	1500	59	1800	71	1500	59	1800	71
	kg	lb	kg	lb	kg	lb	kg	lb	kg	lb	kg	lb
Weight	205	452	390	860	281	620	334	736	205	452	235	518
	190	420	390	860	270	595	323	712	210	463	240	529
Capacity	1200	2645	1200	2645	1200	2645	1200	2645	1000	2210	1000	2210



BARREL GRIPPER [A2210]

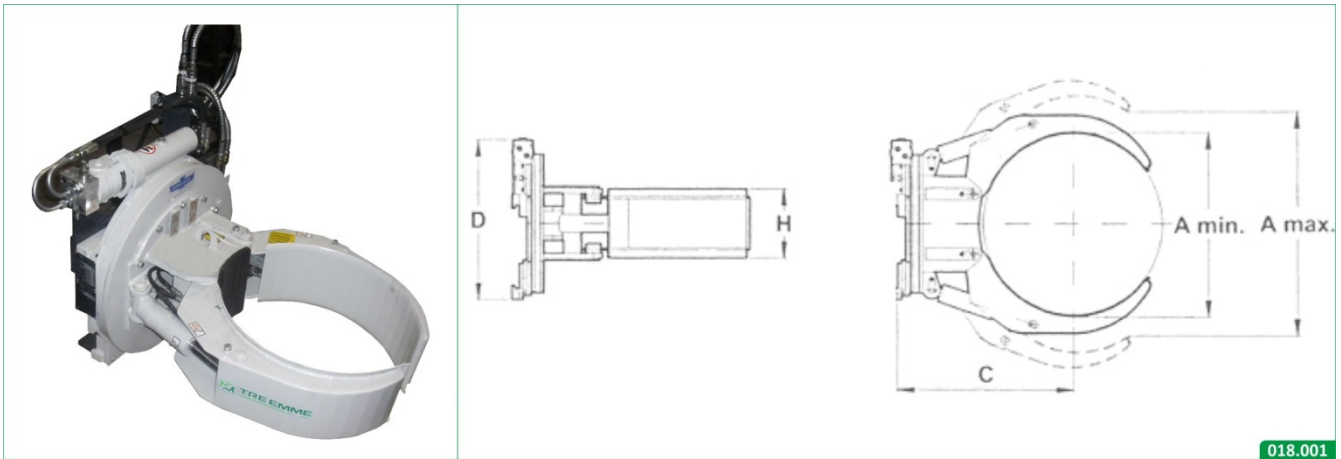

MERLO CODE	A2210	
	mm	in
A	600 - 700	24 ÷ 28
C	590	23
D	725	29
H	230	9
	kg	lb
Weight	275	606
Capacity	600	1325

OTHER ATTACHMENTS

MATERIAL HANDLER [A1900]

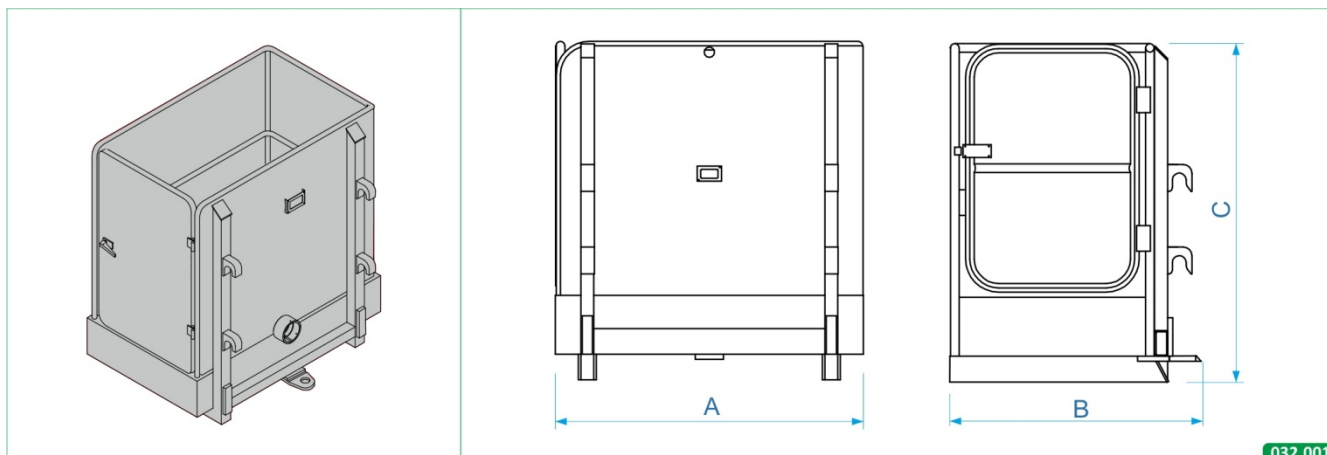

MERLO CODE	A1900	
	mm	in
A	1200	47
B	995	39
C	1320	52
	kg	lb
Weight	200	440
Capacity	1000	2210

For instructions on installing the attachment, refer to MODULE 3 → SECTION 2 → INSTALLING THE ATTACHMENT.

For instructions on the use of the attachment refer to MODULE 1 → SECTION 3 → JOYSTICK.

Unloading and loading material must be performed from the exterior of the attachment and in the presence of an operator in the cab to make sure that the maximum capacity of the attachment is not exceeded or the machine in combination with the attachment (refer to the relative LOAD CHART).



WARNING!



RISK OF ACCIDENTS!

DO NOT LIFT persons on-board the attachment. The **capacity of the attachment** is less than the maximum capacity of the machine.



CONCRETE MIXING BUCKET [A1400 | A1410 | A1420 | A1430]

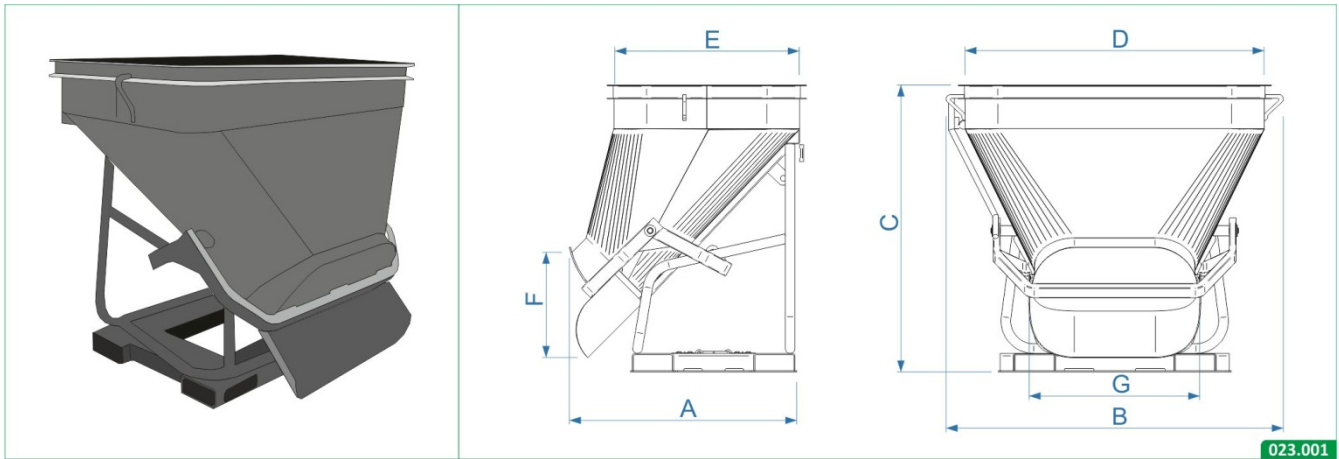

MERLO CODE	A1400 - A1410		A1420 - A1430	
	mm	in	mm	in
A	1035	41	1035	41
B	1470	58	1470	58
C	1250	49	1450	57
D	1300	51	1300	51
E	810	32	810	32
F	480	19	480	19
G	740	29	740	29
	kg	lb	kg	lb
Weight	255	562	275	606
Capacity	1250	2755	1750	3858
	l	gal	l	gal
Load capacity	500	131	700	183

To install the attachment on the carriage, insert the STANDARD FORKS in the specific seats (A) for side installation or (B) for front installation.

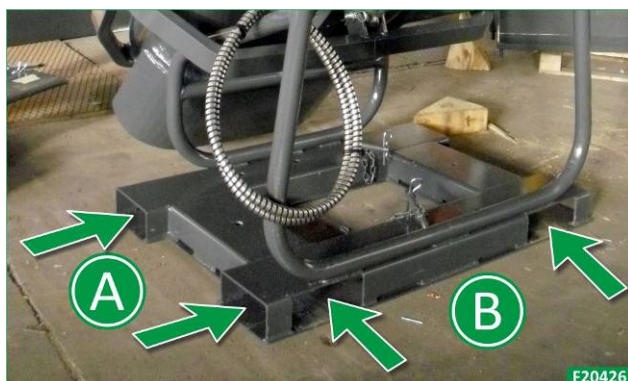

Lift the attachment and secure it to the forks using the **pins** and the **wrenches**.



WARNING!



RISK OF ACCIDENTS!

Before using the attachment, make sure **the pins are locked correctly** to prevent accidental exit from their seats.

Bucket with hydraulic aperture

For the hydraulic connection, refer to **MODULE 3 → SECTION 2 → INSTALLING THE ATTACHMENT → HYDRAULIC CONNECTION**.



WARNING



LOAD CHART.

Refer to the **load chart** for the machine with STANDARD FORKS assuming the load to be the **weight of the attachment** plus the **weight of the material** loaded inside.

For the controls of this attachment, refer to **MODULE 1 → SECTION 3 → JOYSTICK**.

Bucket with manual aperture

Use the **lever (L)** to open and close the material unloading hatch.

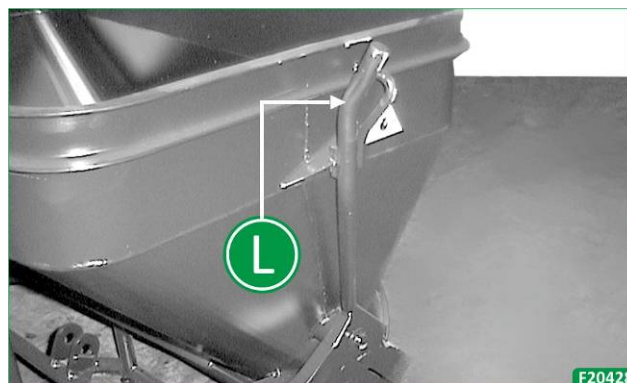

WARNING!



RISK OF ACCIDENTS!

Keep the concrete mixing bucket **level** during use.

DO NOT SLANT the concrete mixing bucket to perform material unloading operations.



MIXING BUCKET [A1565 | A1570 | A1571 | A1580 | A1581 | A1582 | A1583]

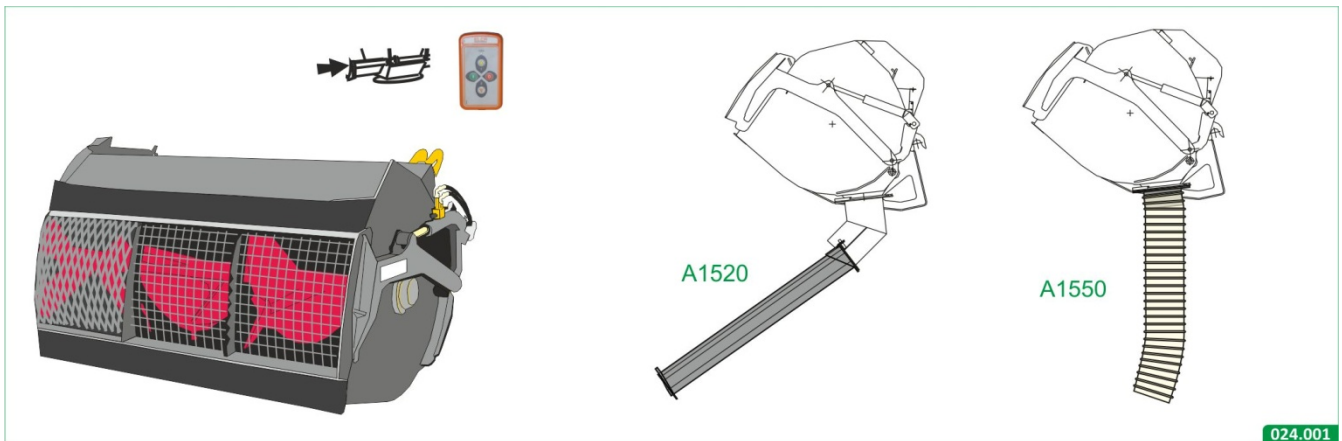

024.001

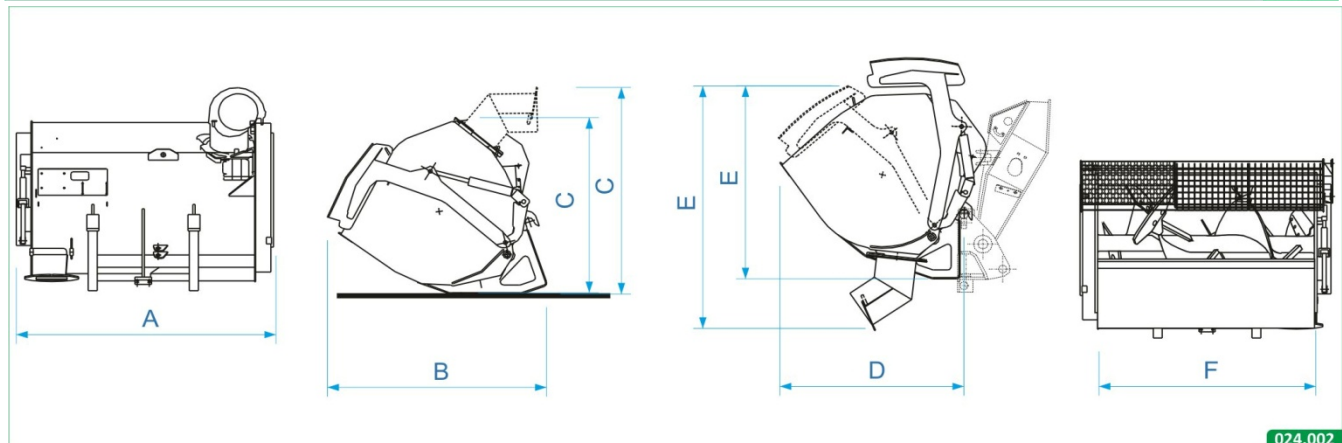

024.002

MERLO CODE	A1565		A1570 A1571		A1580 A1581	
	mm	in	mm	in	mm	in
A	1270	50	1720	67.7	2230	88
B	1500	59	1500	59	1500	59
C	1140 ÷ 1400	45 ÷ 55	1140 ÷ 1400	45 ÷ 55	1140 ÷ 1400	45 ÷ 55
D	1300	51	1170	46	1170	46
E	1270 ÷ 1610	50 ÷ 63	1270 ÷ 1610	50 ÷ 63	1270 ÷ 1610	50 ÷ 63
F	1060	42	1710	67	2225	88
G	620	24	620	24	620	24
H	2575	101	2575	101	2575	101
	kg	lb	kg	lb	kg	lb
Weight	690	1520	750	1655	880	1940
Capacity	875	1930	1250	2760	1875	4140
	l	gal	l	gal	l	gal
Load capacity	350	90	500	130	750	195



For instructions on installing the attachment, refer to MODULE 3 → SECTION 2 → INSTALLING THE ATTACHMENT.

For instructions on the use of the attachment refer to MODULE 1 → SECTION 3 → JOYSTICK.

Bucket loading

- ▶ Lower and completely retract the boom and **slightly tilt the bucket** downwards.
- ▶ Turn the selector switch (MC) to position "1";; open the **front guard** (refer to **MODULE 1 → SECTION 5 → CONTINUOUS DELIVERY OF HYDRAULIC OIL**).

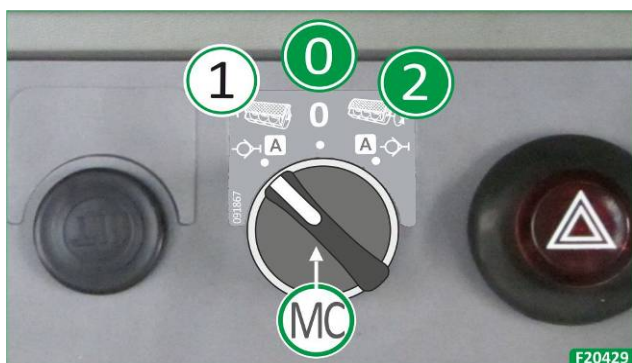

- ▶ Turn the selector switch (MC) to position "2" when the front guard is completely open: **continuous propeller rotation** is activated (refer to **MODULE 1 → SECTION 5 → CONTINUOUS DELIVERY OF HYDRAULIC OIL**). The front guard remains raised.

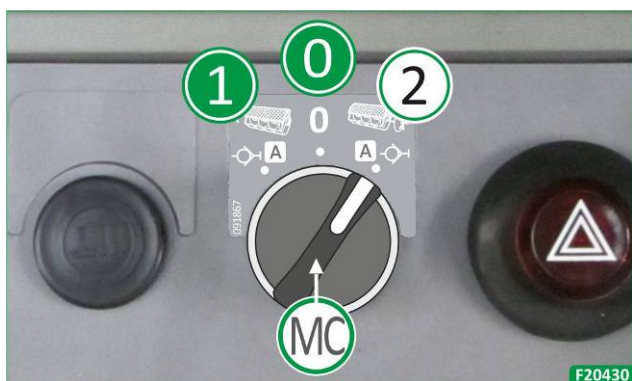

- ▶ Use the bucket as a **loader** by moving slowly forward with the machine to load the material.
- ▶ Tilt the bucket upwards to retain the material loaded and obtain **automatic front guard closure**.



WARNING!



RISK OF ACCIDENTS!

When the bucket is **tilted upwards**, **propeller rotation** is de-activated until the complete closure of the front guard.



WARNING!



RISK OF ACCIDENTS!

DO NOT LOAD the bucket manually when the front guard is raised.



Loading the bucket manually**WARNING!****RISK OF ACCIDENTS!****DO NOT EXCEED** the maximum capacity.

- ▶ Tilt the bucket upwards to **close the front guard**.
- ▶ Turn the selector switch (MC) to position "2"; **continuous propeller rotation** is activated (refer to **MODULE 1** → **SECTION 5** → **CONTINUOUS DELIVERY OF HYDRAULIC OIL**).

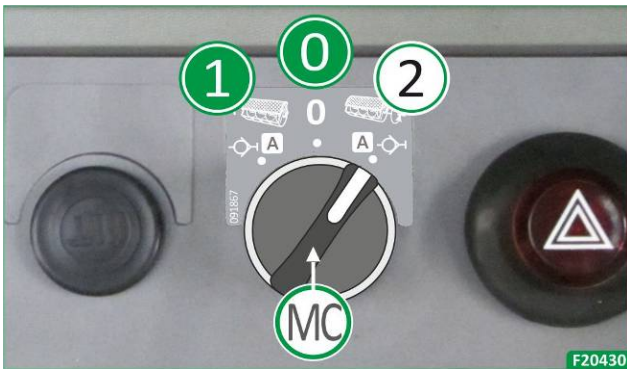

- ▶ Fill with **bulk cement** through the specific grille (A) or place a **bag of cement** on the blade (B) to open it.

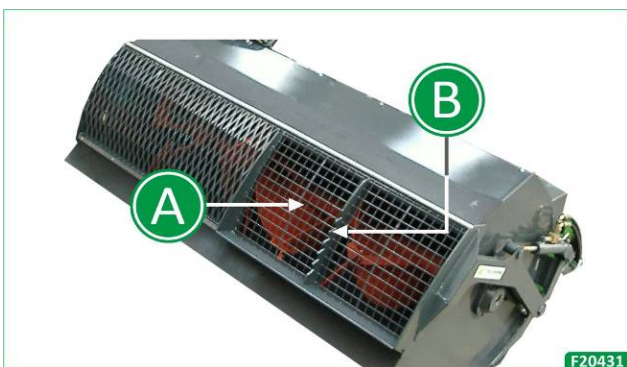
**WARNING****MAXIMUM BUCKET CAPACITY.**

Maximum capacity is reached with the carriage in a vertical position, when the material reaches the edge of the bucket (ref. MAX).

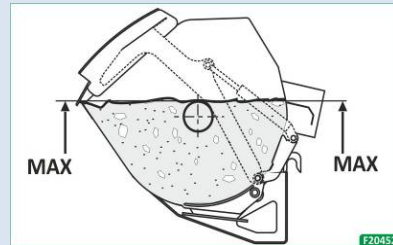
Unloading chute assembly

Work with the boom raised to about 1.5 m (59 in) from ground level with the **engine OFF**.

**WARNING!****RISK OF INJURIES!**

DO NOT TAKE UP A POSITION underneath the attachment during the following operations.

- ▶ Extract the chute from the transport position and release the **bracket (1)**.
- ▶ Insert the chute **guideways (2)** near the material unloading hatch.

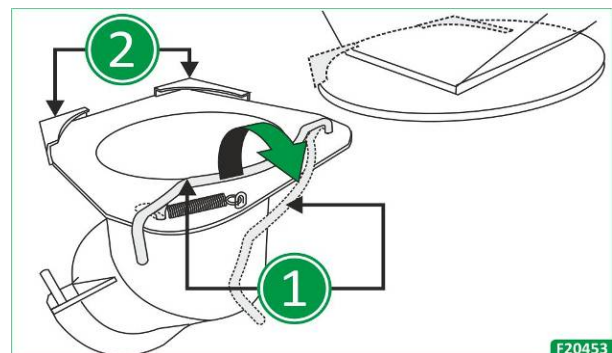

- ▶ Re-connect the bracket (1) and check the lock and function of the spring (3).

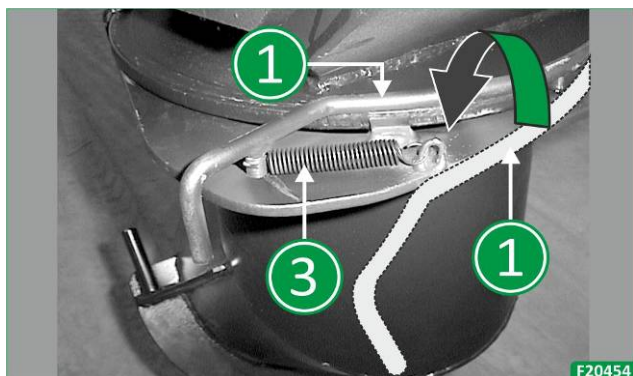

Unloading chute disassembly

- ▶ Release the bracket (1).
- ▶ Rotate the chute and remove it from the unloading hatch.

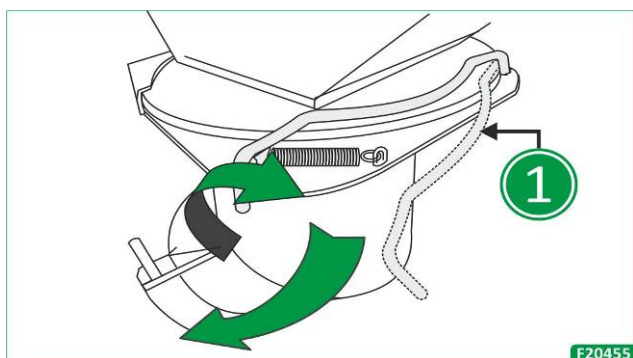

Chute transportation

Insert the chute in its seat on the upper part of the attachment.



WARNING



RISK OF DAMAGE TO THE CHUTE.

DO NOT OPERATE front guard aperture when the chute is in the transport position.



Unloading concrete

- ▶ Tilt the bucket upwards to close the front guard.
- ▶ Turn the selector switch (MC) to position "2"; continuous propeller rotation is activated;
- ▶ Use the **radio control** supplied:
 - ▶ **A:** opening the unloading hatch.
 - ▶ **B:** closing the unloading hatch.



For other radio control functions, refer to the relative instructions.



Maintenance every 10 hours

To wash the inside of the bucket with the propeller moving, keep the front guard closed.

To wash the inside of the bucket with the front guard raised, the engine must be OFF.

Maintenance every 50 hours

- ▶ Grease the bearings on both sides of the propeller using the grease unit (A) until grease emerges from hole (B).

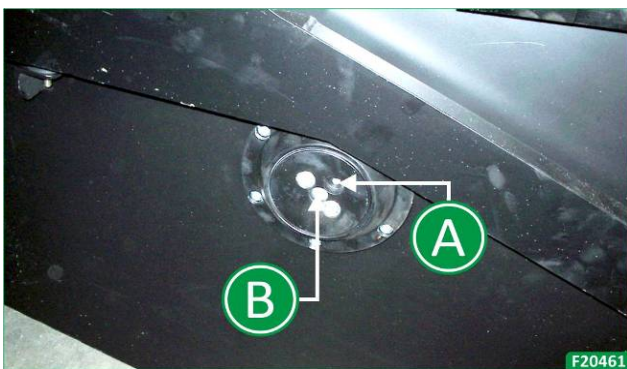

- ▶ Close the bucket's front guard.
- ▶ Start propeller rotation and grease the chain using the grease unit (D).

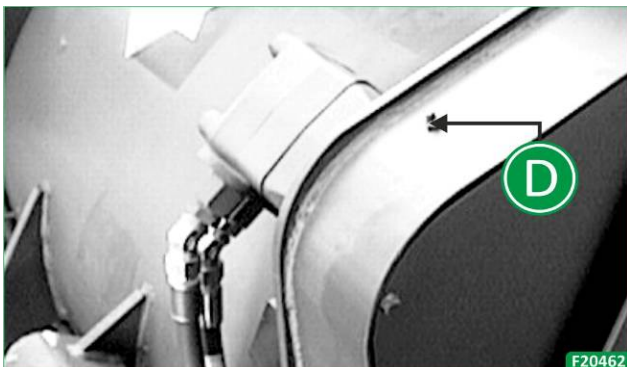
**Unloading chute extension**

- ▶ Insert the bracket (A) of the extension unit into pin (B) on the unloading chute.

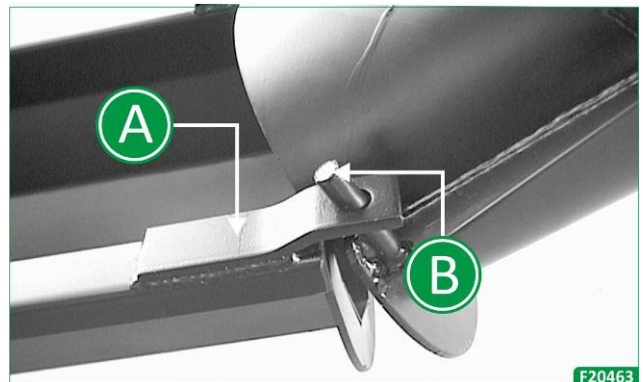

- ▶ **Rotate the extension** until its edge rests against the unloading chute.

Unloading pipe

- ▶ Couple the unloading pipe flange to the bucket, using the angle hooks.
- ▶ Rotate the thread pin (D) upwards.
- ▶ Close the wing nut.

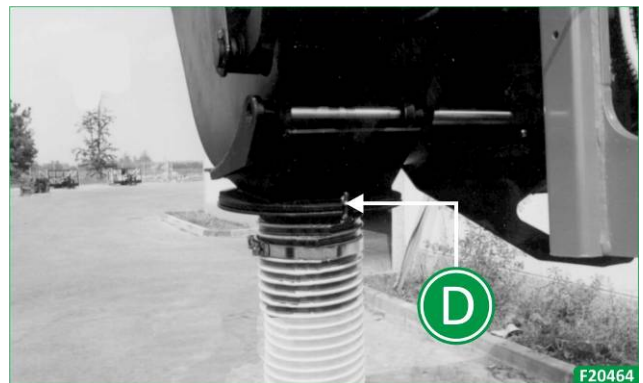

ATTACHMENTS FOR SUSPENDED LOADS

For instructions on installing the attachment, refer to MODULE 3 → SECTION 2 → INSTALLING THE ATTACHMENT.

For instructions on the use of the attachment refer to MODULE 1 → SECTION 3 → JOYSTICK.

If the machine is equipped with load limiter, refer to MODULE 1 → SECTION 3 → LOAD LIMITER WITH ATTACHMENT FOR SUSPENDED LOADS.



WARNING!



RISK OF ACCIDENTS!

Violent blows to the attachment can cause serious damage to the quick-coupling system and the **accidental release** of the attachment itself.



WARNING!



RISK OF ACCIDENTS!

DO NOT use the attachment to drag the load.



WARNING!



RISK OF ACCIDENTS!

DO NOT use the attachment to drag the load.



WARNING!



RISK OF ACCIDENTS!

DO NOT use the attachment without having connected the load limiter (if the machine is equipped).



CARRIAGE-MOUNTED HOOK [A1000]

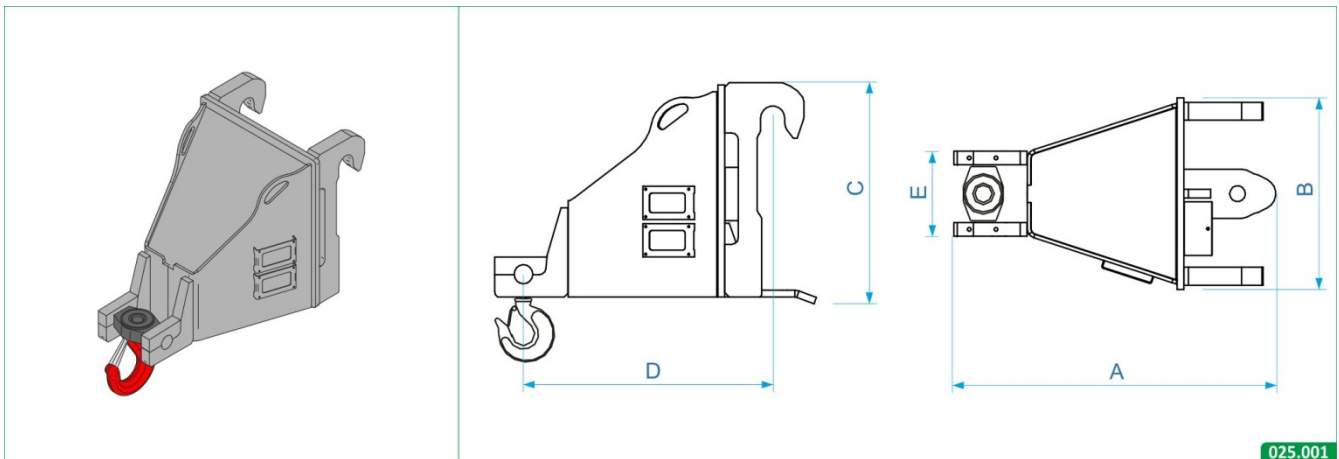

MERLO CODE	A1000	
	mm	in
A	725	29
B	430	17
C	495	19
D	560	22
E	190	7
	kg	lb
Weight	100	220
Capacity	4500	9900

**PRECAUTION****RISK OF ACCIDENTS!**

Always operate with the attachment levelled.

**WARNING!****RISK OF ACCIDENTS!**

Before using the attachment, refer the load chart to identify the **maximum capacity** of the attachment in combination with the machine.

LIFTING BOOM [A1118B]

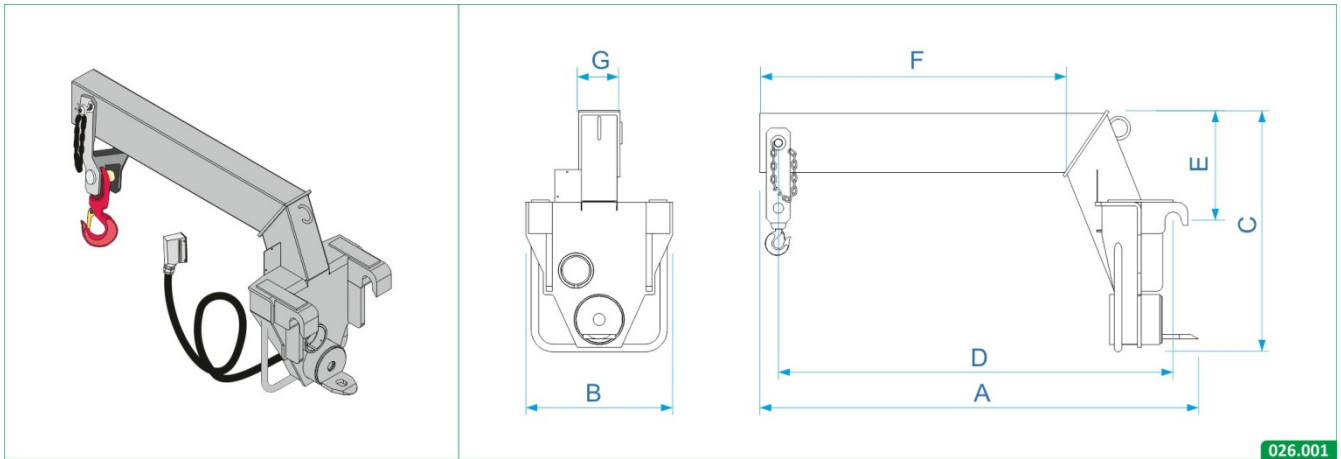

MERLO CODE	A1118B	
	mm	in
A	1485	58
B	495	19
C	815	32
D	1335	52
E	365	14
F	1030	46
G	140	6
	kg	lb
Weight	125	275
Capacity	2200	4850



PRECAUTION



RISK OF ACCIDENTS!

Always operate with the attachment levelled.



TELESCOPIC LIFTING BOOM [A1123B]

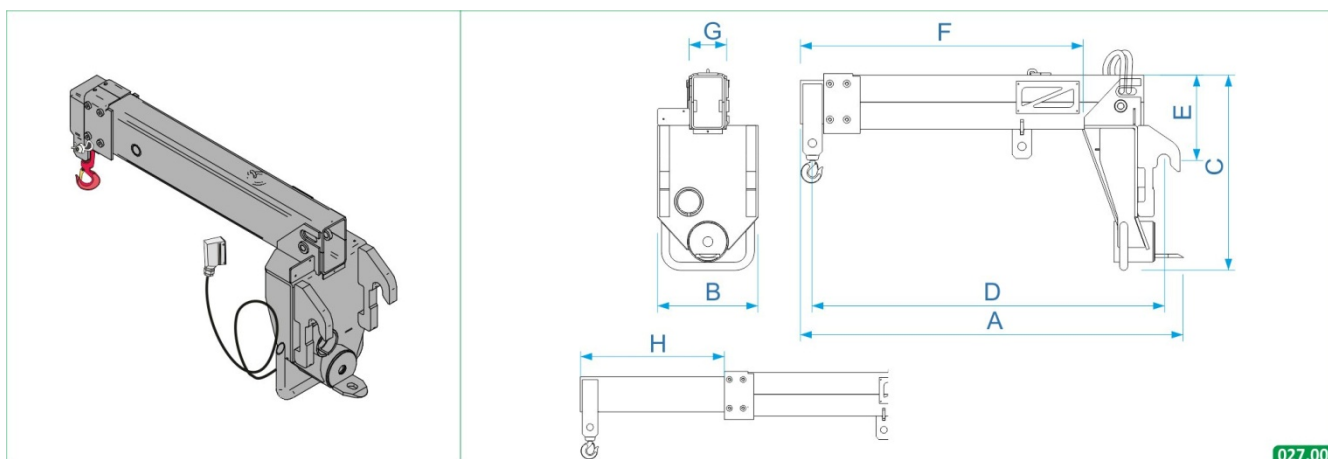

MERLO CODE	A1123B	
	mm	in
A	1580	62
B	475	19
C	810	32
D	1445	57
E	355	14
F	1160	46
G	170	7
H	725	29
	kg	lb
Weight	220	485
Capacity	1500	3310



PRECAUTION



RISK OF ACCIDENTS!

Always operate with the attachment levelled.

FLY JIB [A1200B | A1210B | A1230B]

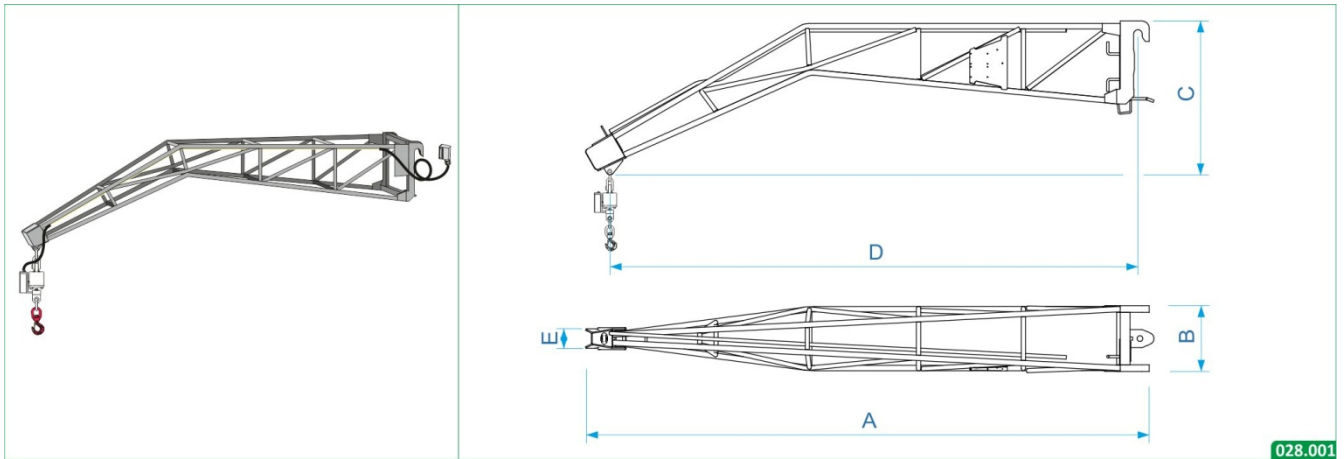

MERLO CODE	A1200B		A1210B		A1230B	
	mm	in	mm	in	mm	in
A	3470	137	2115	83	3470	137
B	400	16	440	17	400	16
C	940	37	575	23	970	38
D	3225	127	1910	75	3225	126
E	135	5	155	6	135	5
	kg	lb	kg	lb	kg	lb
Weight	112	247	120	265	125	276
Capacity	600	1320	1500	3310	400	880



PRECAUTION



RISK OF ACCIDENTS!

DO NOT USE the attachment with the carriage rotated downwards.



TRANSPORTING THE ATTACHMENT FOR CIRCULATION ON PUBLIC ROADS



WARNING



POSITIONING THE FLY JIB.

Positioning the fly jib in the housing on the RH side of the machine requires two operators and additional lifting attachment.

- ▶ Pull the **pin (T)** and turn the **front support (A)** outwards [figure 1].

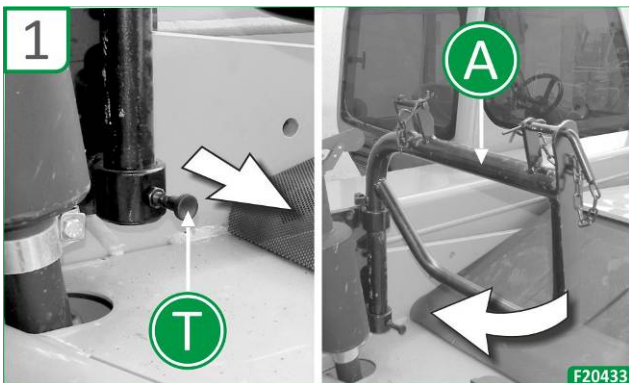

- ▶ Remove the wrench[®] and the pins (P).

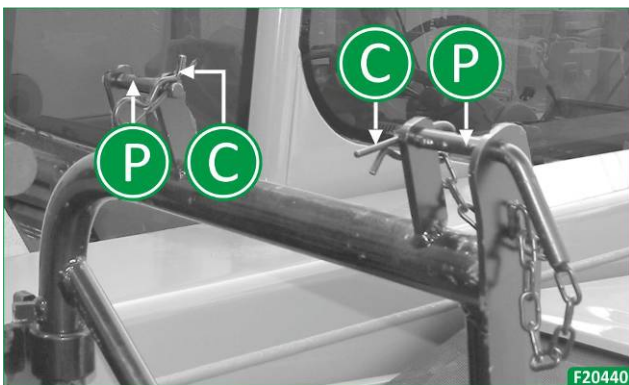

- ▶ Connect the 2 lifting accessories at the specific **points (G)** on the attachment (refer to section LIFTING THE ATTACHMENT) [figure].
- ▶ Lift the attachment from the ground using **the additional lifting equipment** [figure 2].

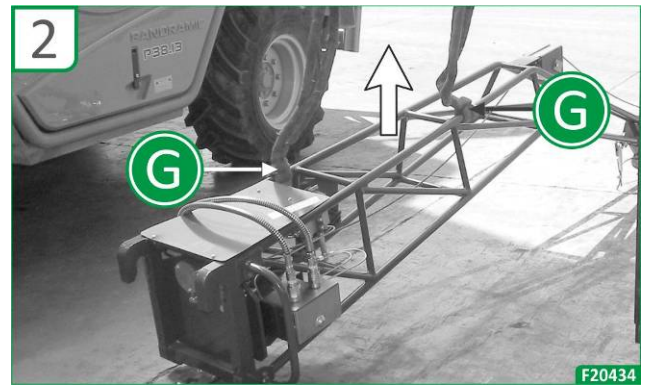

- ▶ With the assistance of a second operator, position the fly jib on the **bar (A)** of the rear support inside the two specific seats [figure 3].

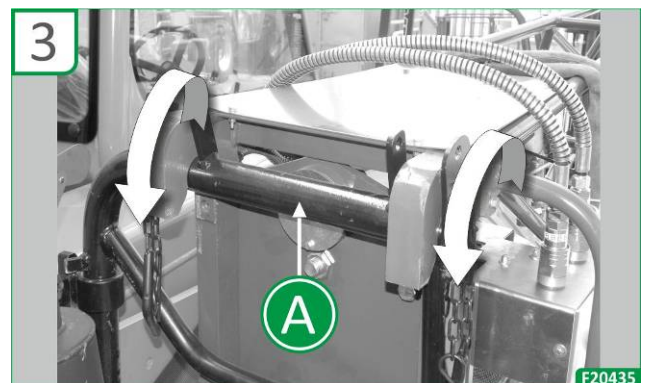

- ▶ Lock the fly jib by inserting the two **pins (P)** and relative **wrenches[®]** [figure 4].

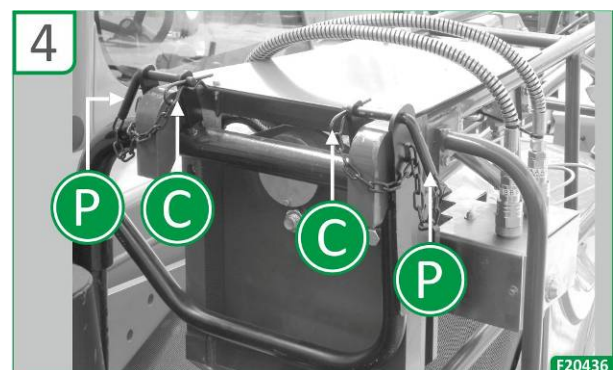

- ▶ Turn the fly jib inwards and position the specific **retainer (B)** on the **front support (T)**. Insert the **screw (R)** and lock the position with the **cotter (S)** [figure 5].

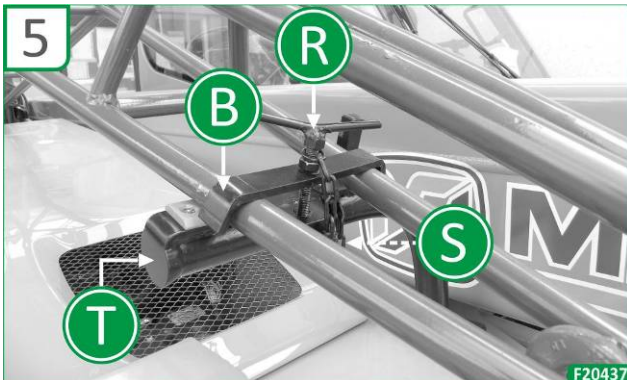

- ▶ To **open the engine compartment** with the fly jib positioned [figure 6], remove the front fasteners [figure 5], pull the **pin (P)** [figure 1] and rotate the fly jib outwards.

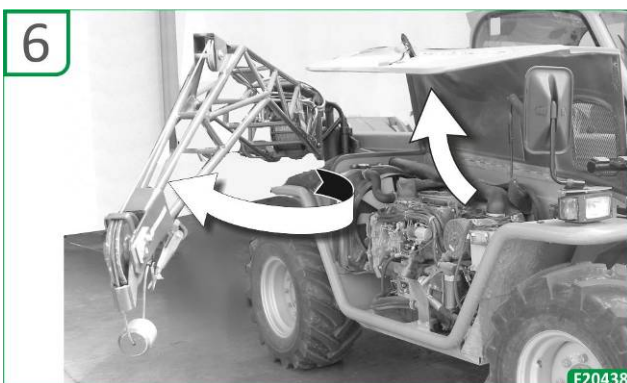

FLY JIB WITH WINCH [A1300B | A1310B | A1330B | A1215B]

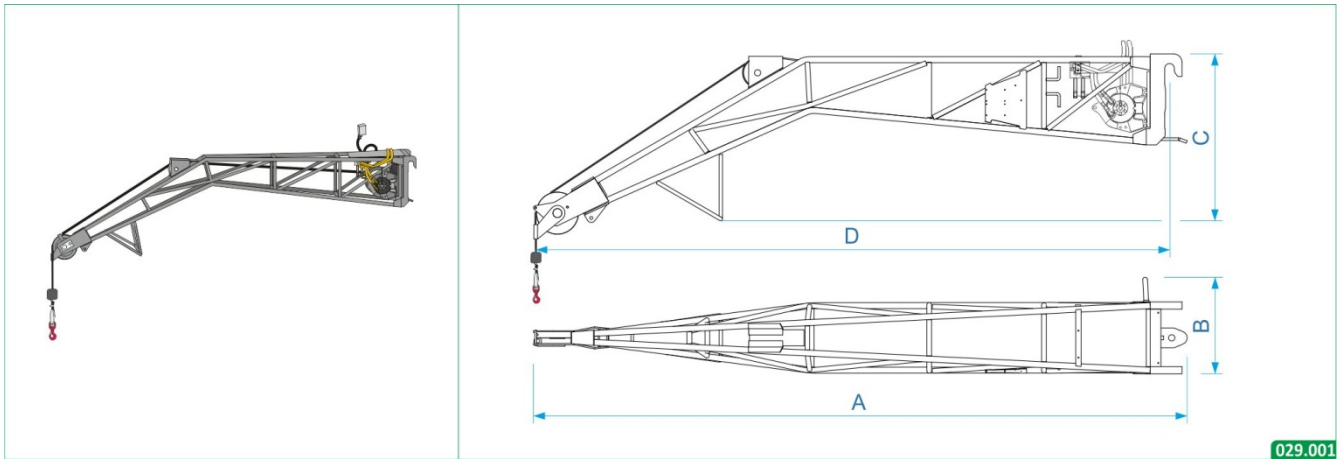

MERLO CODE	A1300B		A1310B		A1330B		A1215B	
	mm	in	mm	in	mm	in	mm	in
A	3645	144	2230	88	3645	144	1660	65
B	540	21	580	23	540	21	735	29
C	1000	39	680	27	1000	39	805	32
D	3535	139	1975	78	3535	139	1550	61
∅ cable	7	1/4	7	1/4	7	1/4	10	3/8
	kg	lb	kg	lb	kg	lb	kg	lb
Weight	202	445	288	635	215	474	290	640
Capacity	600	1320	1500	3310	400	880	2000	4400
	m	ft	m	ft	m	ft	m	ft
Max hook travel	30	98'5"	30	98'5"	30	98'5"	30	98'5"
	m/min	ft/min	m/min	ft/min	m/min	ft/min	m/min	ft/min
Max hook speed	47	154'2"	19	62'4"	44	144'4"	30	98'5"
N° of cable winches	1		2		1		1	

TRANSPORTING THE ATTACHMENT FOR CIRCULATION ON PUBLIC ROADS

Refer to the information provided for the fly jib.

PRELIMINARY OPERATIONS

Remove the hook from the rest position and carefully place it in the **work position**.



PRECAUTION

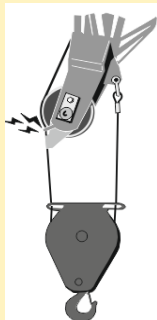

RISK OF ACCIDENTS!

DO NOT use the attachment with the carriage rotated **downwards** because interference between the cable and the cable guide may damage it.



PRECAUTION



RISK OF DAMAGE TO THE CABLE!

DO NOT FORCE the cable descent or boom lowering command when the load is resting on the ground to avoid **unwinding the cable incorrectly**.



WARNING



UNINSTALLING THE ATTACHMENT.

Before uninstalling the attachment, place the hook in the **rest position**.

A1310 | A1320



A1215



A1300



When laying the attachments on the ground, check that the cable is not **pinched**.

MAINTENANCE EVERY 50 HOURS

Hoist: grease nipples 1 and 2.

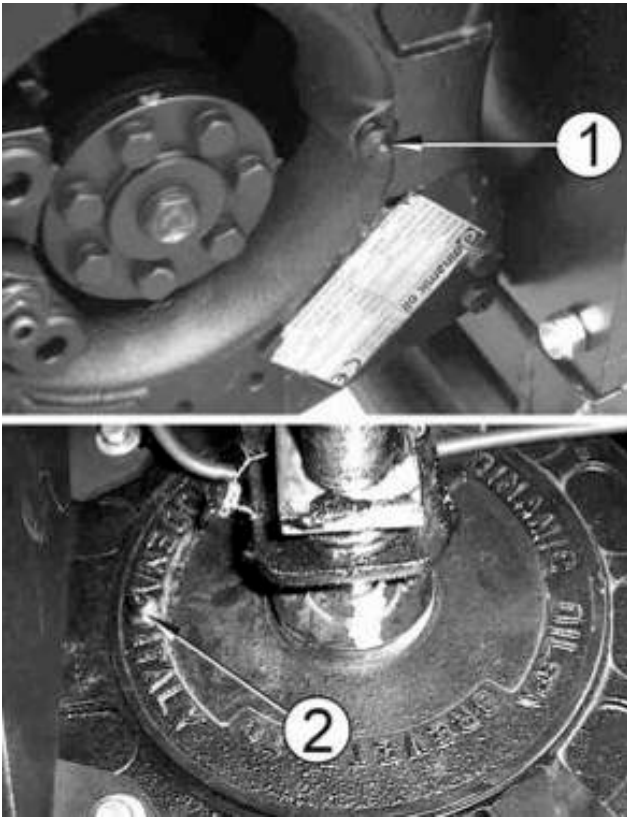

Limit switch: Grease the screw.



Block pulley Grease the pin indicated.

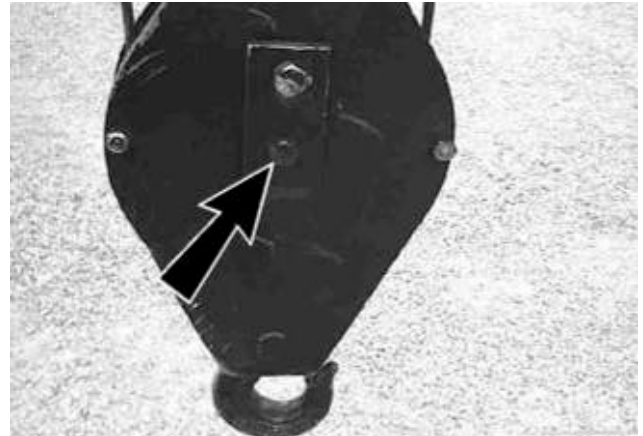

Cable drive pulley: Grease the pin indicated.



CARRIAGE-MOUNTED WINCH LIFT/SW [A2765]

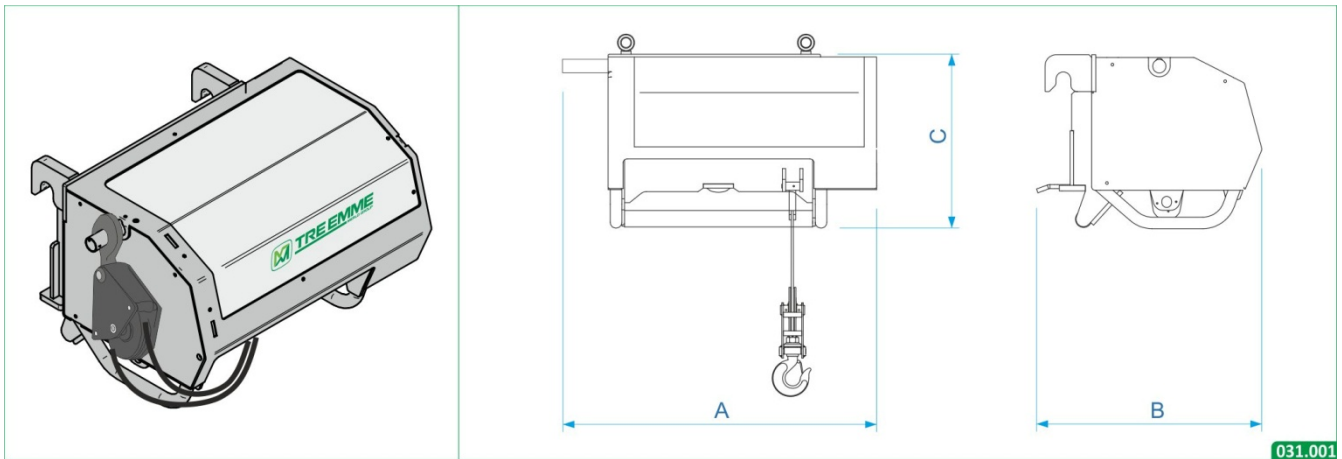

MERLO CODE	A2765	
A	1105	44
B	830	33
C	635	25
Ø cable	12	1/2
	kg	lb
Weight	430	950
Capacity	4000	8800
	m	ft
Cable length	57	187'
Hook travel	30	98'5"
	m/min	ft/min
Hook speed	28	91
N° cable winches	2	

**WARNING****UNINSTALLING THE ATTACHMENT.**

Before removing the attachment, place the block (B) in the **rest position** and lock it with the specific yoke (A).

When laying the attachments on the ground, check that the cable is not **pinched**.

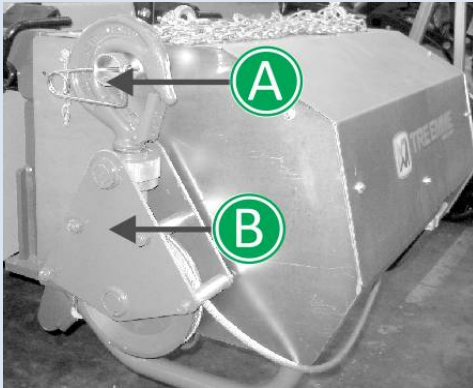
**PRECAUTION****RISK OF ACCIDENTS!**

DO NOT USE the attachment with the carriage tilted because interference between the cable and the cable guide may damage it.

**PRECAUTION****RISK OF DAMAGE TO THE CABLE!**

DO NOT FORCE the cable descent or boom lowering command when the load is resting on the ground to avoid **unwinding the cable incorrectly**.

TRANSPORTING THE ATTACHMENT FOR CIRCULATION ON PUBLIC ROADS (only ROTO models)

**WARNING****POSITIONING THE WINCH.**

Positioning the winch on the support requires assistance of **another operator on the ground** (OPERATOR 2) and the use of a **lifting accessory**.

**WARNING!****RISK OF ACCIDENTS!**

DO NOT USE the anchor point on the second extension of the machine's boom to **lift a load**.

- ▶ Remove the winch and **place it on the ground**.
- ▶ (OPERATOR 2) Pull the two **handles (M)** on the support outwards and turn them downwards.

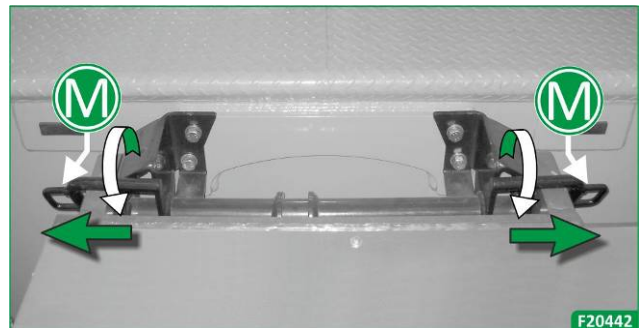

- ▶ (OPERATOR 2) Connect the lifting accessory to the **anchor point** on the second extension of the machine's boom.

- ▶ Handle the machine's boom in order to **suspend the lifting accessory** with the free end at the specific lifting point of the attachment (refer to **MODULE 3 → SECTION 2 → LIFTING**).
- ▶ (OPERATOR 2) Couple the free end of the lifting accessory to the **attachment's lifting point** [figure 2].
- ▶ Use the boom's movements to lift and handle the attachment **until it is coupled with the support** [figures 3 and 4]. (OPERATOR 2) From the ground, manually guide the positioning of the attachment until it is coupled on the support.

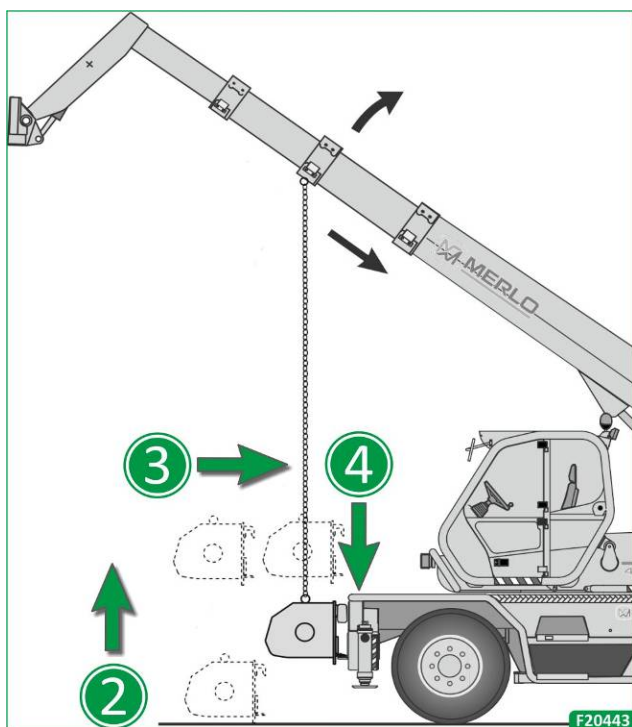

- ▶ Retract and lower the **boom**.
- ▶ (OPERATOR 2) Remove the lifting accessory

MAINTENANCE

Every 50 hours of operation grease:

- A) The block pin.
- B) The cable lug coupling.



- ▶ **EVERY 1000 HOURS of operation**, remove the protective casing (1, 2, 3) using a 10mm hex wrench and grease:



- C) The cable.
- D) The cable winder block screw.

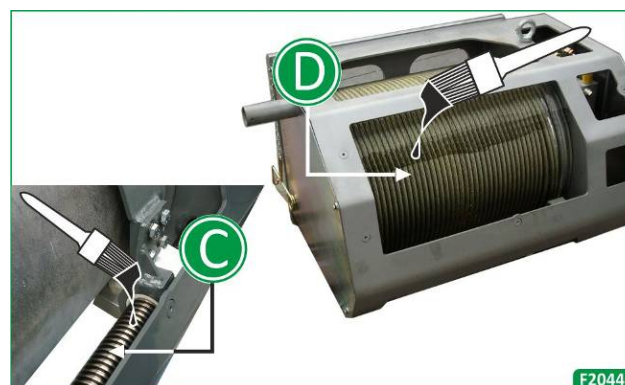

E) The transmission chain.

F) The limit switch drive rod.

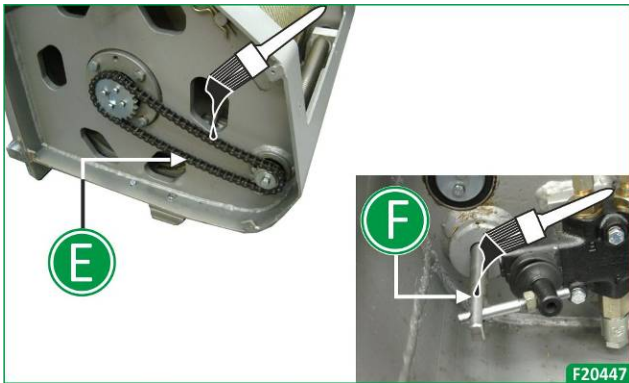

Check:

G) Reducer oil level. The level indicator must be completely submerged.

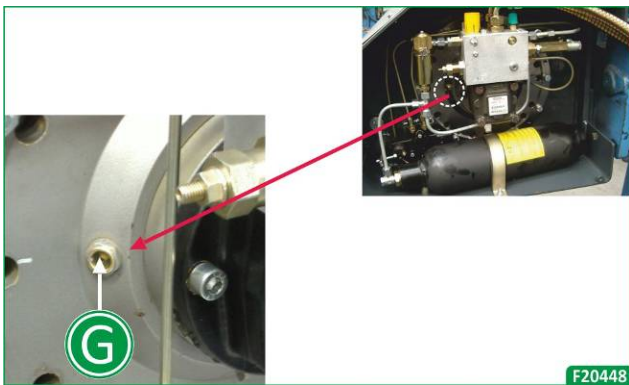

H) Cable guide block wear.

(L) Cable guide block bushing wear.

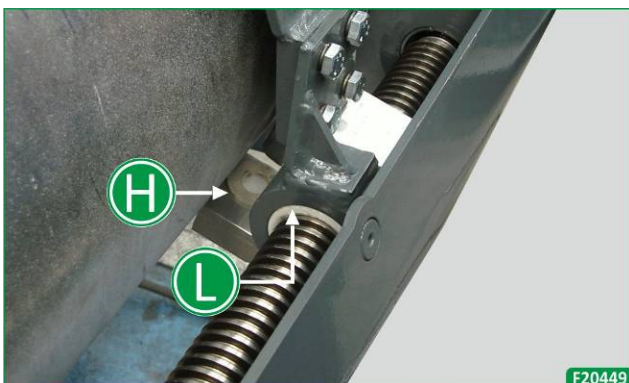

PLATFORMS

Refer to the relative manual.



WARNING!



RISK OF ACCIDENTS!

DO NOT LIFT people if the machine is not pre-set and equipped with an **overhead work platform** approved by Merlo.





